



벤처기업



벤처디자인



ISO 9001 / KSA9001 인증기업

INNOBIZ  
중소기업 기술혁신 협회

koita  
기업부설연구소



# SUNGIL

Micro Couplings  
Support Units  
Power Lock  
FA Units





## All the products made by Sungil are reliable.

All the first domestic company that has developed zero backlash small precision coupling in Korea, Sungil Machinery manufactures zero backlash oldham, disk, radial beam, cross joint, jaw and Flexible, Gum Type, rigid coupling through industrial and educational cooperation, research and development and relentless effort to make ultra-precision machinery items.

The company received Korea Venture Design Award for its compact design of coupling and was recognized for its quality and technology by exhibiting products at various domestic and foreign exhibitions such as Hanover Exhibition (exhibition of factory automation) in Germany.

Through such activities, Sungil Machinery has made its coupling into small coupling with world-class general brand.

In addition, SI Machinery recently introduced a series of support units, which had been exported to Southeast Asia, EU and America together with coupling, into Korean market for the first time. SI Machinery's support units provide micron unit precision in the straightness, parallelism and right angle of housing. SI Machinery maximized the performance of motion and control such as slow start and low torque through ultra-precision process in all parts including oil seal, collar and nuts.

SUNGIL MACHINERY CO., LTD. takes full responsibility as a general brand of FA parts and always guarantees ultra-precision and high performance in all products.

We deeply appreciate your attention and support.

*High Performance!*  
*High Reliability!*  
*High Quality!*



# Contents

## Micro Couplings

04 Notice for the use SI Coupling

RoHS

05 Radial Beam Coupling



25 Cross Joint Coupling



09 Oldham Coupling



27 Flexible Coupling



13 Disk Coupling



28 Jaw Coupling



19 High Torque Flexible Disk Coupling



35 Release on November  
Gum Type Flexible Coupling



23 Rigid Coupling



## Support Units

40 Characteristics & Step of installation

RoHS

44 EK, EF Type Support Unit



50 FK, FF Type Support Unit



46 BK, BF Type Support Unit



53 CK, CF Type Support Unit



48 AK, AF Type Support Unit



## FA Units

RoHS

56 Joint Unit



59 Set Collars



58 Bearing Unit



60 Lock Nut



## Power Lock

RoHS

62 Release on November  
SAPC Series



65 Release on November  
SAPA Series



# Sungil Micro Coupling

## Micro Coupling

### Alignment Adjustment

- ① Flexible coupling can transmit torque and rotation angle while allowing misalignment. When the misalignment gets higher than limit, vibration may occur and the life of coupling may be reduced. Make sure to adjust the alignment accordingly
- ② There are three types of shaft misalignments such as eccentricity (error in parallel alignment), angularity (error in angular alignment) and end-play (shift axle direction). Adjust the alignment to be lower than limit listed in the specification table of each product provided in this catalog.
- ③ The limit of misalignment recorded in this catalog is for one misalignment for eccentricity, angularity and end-play. When there are more than 2 misalignments, we recommend you to apply 1/2 of misalignment limit
- ④ Misalignments are sometimes caused not only by equipment assembly but also by vibration, heat expansion, wear of bearings and so forth during operation. Therefore, it is recommended to adjust the shaft misalignment to be below 1/3 of maximum limit.

#### ■ Parallel Offset Misalignment

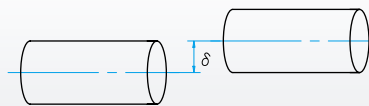

#### ■ Combined Angular-Offset Misalignment

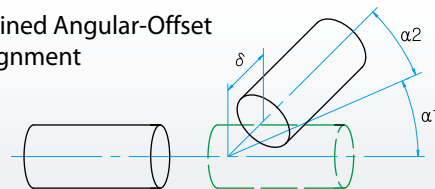

#### ■ Symmetrical Angular Misalignment

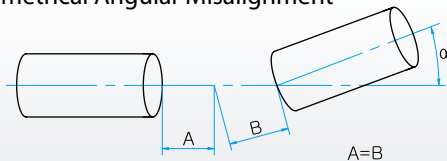

#### ■ End-Play

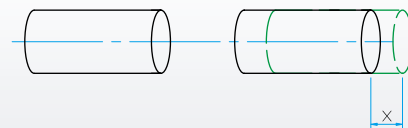

#### ■ Non-Symmetrical Angular Misalignment

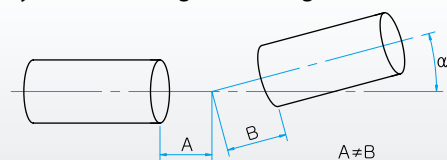

#### ■ Run Out

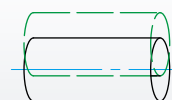

### Adjustment of Torque according to Temperature

SOH, SFC, SJC, SGF use polyurethane, polyacetal or plastic parts or Anti-Vibration Rubber. These models must be used in the operational temperature indicated in this catalog.

When ambient temperature exceeds 30°..., maximum torque and rated torque should be checked by the correction value chart beside.

Category Temperature	Correction Value
-20℃ ~ 30℃	1.0
30℃ ~ 40℃	0.8
40℃ ~ 60℃	0.6
60℃ ~ 100℃	0.5

### Cautions

- Misalignment exceeding maximum limit and excessive torque may result in shorter life of coupling due to plastic deformation.
- Stop machine operation at once when there is abnormal metallic noise, and proceed to check shaft misalignment, disturbance in shaft rotation, loosen screw and so forth
- When used at rotation machine with significant load fluctuation, apply adhesive on screw to prevent loosening or select a size on higher rank.
- Max Torque is thing that can transfer torque momentarily.
- Rated Torque is thing that can transfer torque continuously.

# SRB Series

## Micro Radial Beam Flexible Coupling



This Product is radial beam type flexible coupling that is made of high strength aluminum alloy (Al7075-T6) and one-piece structure.

### Features

- Zero backlash
- Complete absorption of eccentricity, angularity, and end-play by spring action of radial beam structure.
- High strength aluminum alloy (Al 7075-T6) makes high torsion rigidity and torque, and products are available in aluminum alloy and stainless steel.
- It can be used in high RPM by accurate concentricity and low inertia moment.
- Regular direction and reverse direction are identical and no repair is necessary.
- Excellent durability and oil and chemical resistance.

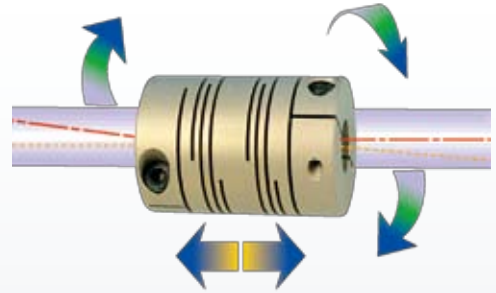

※ Registration of Design 0237181

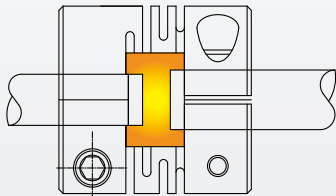

• It is easy to assembly by processing widely the inside of coupling

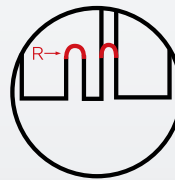

The end part of slit of all Sungil Radial Beam Coupling is machined by round(R). So Stress of flexure of SI SRB is maximized and damage of at the misalignment moment is minimized.

-Registration of Design-  
(※ No machined by round(R) is not SI Product)

### Structure & Material

#### SRB Type



Clamp Type



Set Screw Type

Type	SRB-□□	SRB-□□C	SRBS-□□	SRBS-□□C
Fastening Type	Set Screw	Clamp	Set Screw	Clamp
Material	High strength aluminum alloy (Al 7075-T6)		Stainless Steel	
Surface Treatment	Alumite		-	

#### SRBM Type



Clamp Type



Set Screw Type

Type	SRBM-□□	SRBM-□□C	SRBMS-□□C
Fastening Type	Set Screw	Clamp	Clamp
Material	High strength aluminum alloy (Al 7075-T6)		Stainless Steel
Surface Treatment	Alumite		-

### How to order product



※ Please mark each inner diameter size.

# SRB Series

## Micro Radial Beam Flexible Coupling

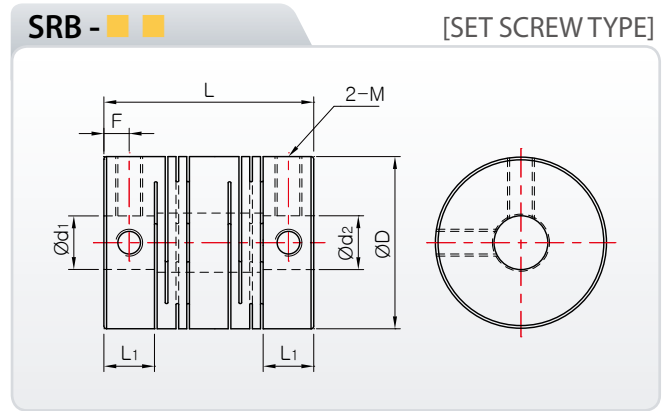
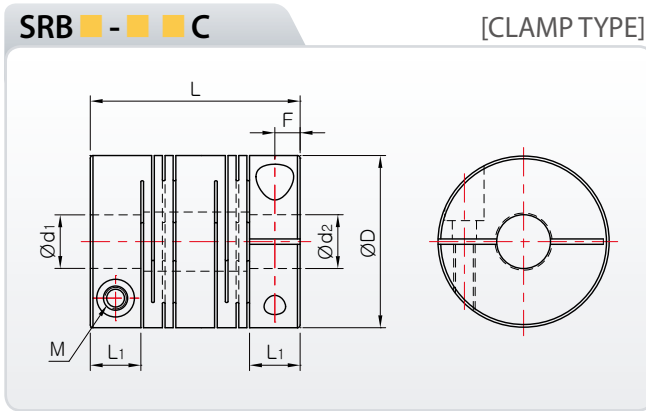

### Standards & Performance

※ Material : High strength aluminum alloy (Al 7075-T6)

Product Number	Dimension (±0.3)				Fastening Bolt M	Fastening Torque (N·m)	Max. RPM (min <sup>-1</sup> )	Max Torque (N·m)	Rated Torque (N·m)	Torsional Stiffness (N·m/rad)	Moment of Inertia (kg·m <sup>2</sup> )	Mass (g)	Errors of Misalignment		
	D	L	L <sub>1</sub>	F									Angle (°)	Parallel (mm)	End-Play (mm)
SRB-12C	12.7	19	5	2.5	M2	0.5	12,000	0.4	0.2	36	8.8 × 10 <sup>-8</sup>	3.8	2.5	0.1	±0.3
SRB-16C	16	21.5	6.1	3	M2.6	1	10,000	0.8	0.4	65	3.1 × 10 <sup>-7</sup>	8.5	2.5	0.15	±0.3
SRB-19C	19.1	23	6.1	3	M2.6	1	8,000	1.2	0.6	140	6.4 × 10 <sup>-7</sup>	12	2.5	0.15	±0.3
SRB-22C	22.2	26.5	7.2	3.6	M3	1.7	7,000	2.0	1.0	170	1.4 × 10 <sup>-6</sup>	19	2.5	0.15	±0.4
SRB-26C	26.2	31.4	7.4	3.7	M3	1.7	6,000	3.0	1.5	240	3.4 × 10 <sup>-6</sup>	33	2.5	0.2	±0.4
SRBA-32C	31.8	39	9.4	4.7	M4	3.5	5,000	5.2	2.6	400	1.0 × 10 <sup>-6</sup>	60	2.5	0.2	±0.4
SRBB-32C	31.8	44	9.4	4.7	M4	3.5	5,000	5.2	2.6	380	1.0 × 10 <sup>-5</sup>	68	2.5	0.2	±0.4
SRBA-39C	39	43	10.8	5.4	M5	8	4,000	13	6.5	520	2.1 × 10 <sup>-5</sup>	95	2.5	0.25	±0.4
SRBB-39C	39	56	12	6	M5	8	4,000	13	6.5	460	3.1 × 10 <sup>-5</sup>	135	2.5	0.25	±0.4
SRBA-49C	49	63.5	15	7.5	M6	13	3,300	26	13	740	9.4 × 10 <sup>-5</sup>	260	2.5	0.25	±0.5
SRBB-49C	49	70	15	7.5	M6	13	3,300	26	13	740	1.0 × 10 <sup>-4</sup>	270	2.5	0.25	±0.5
SRBA-60C	60	76.2	19	9.35	M8	30	2,600	48	24	1,000	2.5 × 10 <sup>-4</sup>	440	2.5	0.25	±0.5
SRBB-60C	60	88	19	9.35	M8	30	2,600	48	24	980	3.0 × 10 <sup>-4</sup>	520	2.5	0.3	±0.5
SRB-12	12.7	18	4.5	2.2	M2.5	0.5	28,000	0.4	0.2	36	8.8 × 10 <sup>-8</sup>	3.6	2.5	0.1	±0.3
SRB-16	16	18.5	4.6	2.3	M3	0.7	24,000	0.8	0.4	65	2.8 × 10 <sup>-7</sup>	7.8	2.5	0.15	±0.3
SRB-19	19.1	22	5.7	2.8	M3	0.7	20,000	1.2	0.6	140	6.4 × 10 <sup>-7</sup>	12	2.5	0.15	±0.3
SRB-22	22.2	25	6.5	3.2	M4	1.7	17,000	2.0	1.0	170	1.4 × 10 <sup>-6</sup>	19	2.5	0.15	±0.4
SRB-26	26.2	30	6.8	3.4	M4	1.7	15,000	3.0	1.5	240	3.4 × 10 <sup>-6</sup>	33	2.5	0.2	±0.4
SRB-32	31.8	39	9.4	4.7	M5	4	12,000	5.2	2.6	400	9.4 × 10 <sup>-6</sup>	62	2.5	0.2	±0.4
SRB-39	39	56	16	6	M5	4	9,500	13	6.5	460	2.8 × 10 <sup>-5</sup>	124	2.5	0.25	±0.4
SRB-49	49	70	20	9.5	M6	7	7,000	26	13	740	1.1 × 10 <sup>-4</sup>	280	2.5	0.25	±0.5
SRB-60	60	88	19	9	M8	15	6,000	48	24	980	3.0 × 10 <sup>-4</sup>	500	2.5	0.3	±0.5

### Standard Inner diameter

Product Number	Standard Inner diameter (d <sub>1</sub> , d <sub>2</sub> ) Standard INNER Diameter (mm)																			
	ø2	ø3	ø4	ø5	ø6	ø6.35	ø8	ø9.525	ø10	ø11	ø12	ø14	ø15	ø16	ø18	ø19	ø20	ø22	ø24	ø25
SRB-12□		●	●	●																
SRB-16□		●	●	●	●															
SRB-19□			●	●	●	●	●													
SRB-22□				●	●	●	●	●	●											
SRB-26□				●	●	●	●	●	●	●										
SRB□-32□							●	●	●	●	●									
SRB□-39□									●	●	●	●	●							
SRB□-49□										●	●	●	●	●	●					
SRB□-60□											●	●	●	●	●	●	●	●	●	●

- INNER diameter INCH type is also available
- Non standard inner diameter product is also available
- KEY TYPE is also available
- We recommend that tolerance of shaft is H7.

# SRB Series Micro Radial Beam Flexible Coupling

Please, download CAD DATA on [www.sungilfa.com](http://www.sungilfa.com)

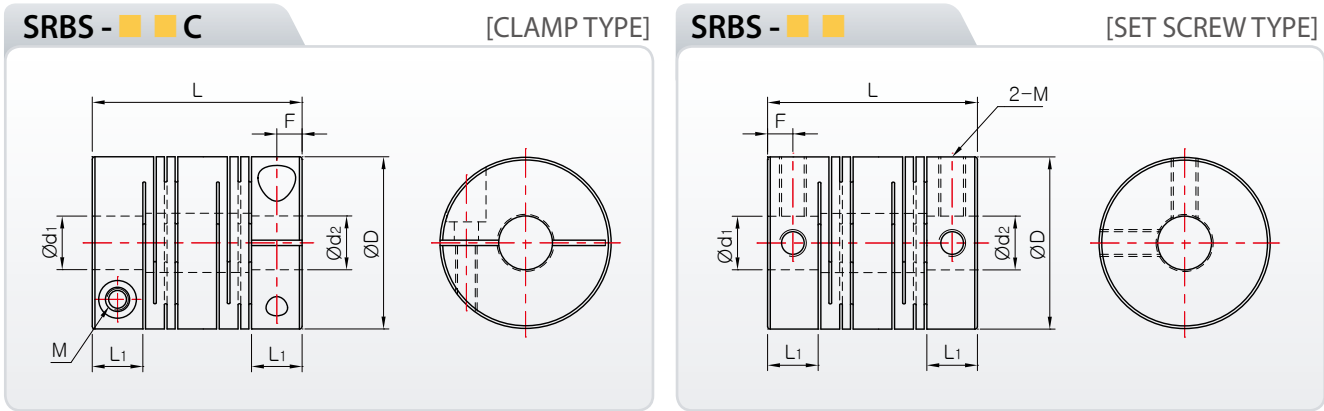

## Standards & Performance

※ Material : Stainless

Product Number	Dimension (±0,3)				Fastening Bolt M	Fastening Torque (N·m)	Max-RPM (min <sup>-1</sup> )	Max Torque (N·m)	Rated Torque (N·m)	Torsional Stiffness (N·m/rad)	Moment of Inertia (kg·m <sup>2</sup> )	Mass (g)	Errors of Misalignment		
	D	L	L <sub>1</sub>	F									Angle (°)	Parallel (mm)	End-Play (mm)
SRBS-12C	12,7	19	5	2,5	M2	0,5	12,000	0,6	0,3	65	3,0 × 10 <sup>-7</sup>	13	2,5	0,1	±0,3
SRBS-16C	16	21,5	6,1	3	M2,6	1	10,000	1	0,5	85	9,0 × 10 <sup>-7</sup>	26	2,5	0,15	±0,3
SRBS-19C	19,1	23	6,1	3	M2,6	1	8,000	1,8	0,9	230	1,7 × 10 <sup>-6</sup>	32	2,5	0,15	±0,3
SRBS-22C	22,2	26,5	7,2	3,6	M3	1,5	7,000	3,2	1,6	290	3,0 × 10 <sup>-6</sup>	43	2,5	0,15	±0,4
SRBS-26C	26,2	31,4	7,4	3,7	M3	1,5	6,000	4,2	2,1	350	8,6 × 10 <sup>-6</sup>	84	2,5	0,2	±0,4
SRBS-32C	31,8	39	9,4	4,7	M4	2,5	5,000	7	3,5	840	2,5 × 10 <sup>-5</sup>	160	2,5	0,2	±0,4
SRBAS-39C	39	43	10,8	5,4	M5	4	4,000	16	8	1,200	4,0 × 10 <sup>-5</sup>	280	2,5	0,25	±0,4
SRBBS-39C	39	56	12	6	M5	4	4,000	16	8	1,000	8,6 × 10 <sup>-5</sup>	360	2,5	0,25	±0,4
SRBAS-49C	49	63,5	15	7,5	M6	8	3,300	32	16	1,600	2,7 × 10 <sup>-4</sup>	710	2,5	0,25	±0,5
SRBBS-49C	49	70	15	7,5	M6	8	3,300	32	16	1,400	2,8 × 10 <sup>-4</sup>	740	2,5	0,25	±0,5
SRBAS-60C	60	76,2	19	9,35	M8	16	2600	60	30	2100	7,2 × 10 <sup>-4</sup>	1150	2,5	0,25	±0,5
SRBBS-60C	60	88	19	9,35	M8	16	2600	60	30	2050	8,6 × 10 <sup>-4</sup>	1370	2,5	0,3	±0,5
SRBS-12	12,7	18	4,5	2,2	M2,5	0,5	28,000	0,6	0,3	65	3,0 × 10 <sup>-8</sup>	13	2,5	0,1	±0,3
SRBS-16	16	18,5	4,6	2,3	M3	0,7	24,000	1	0,5	85	8,4 × 10 <sup>-7</sup>	21	2,5	0,15	±0,3
SRBS-19	19,1	22	5,7	2,8	M3	0,7	20,000	1,8	0,9	230	1,7 × 10 <sup>-7</sup>	32	2,5	0,15	±0,3
SRBS-22	22,2	25	6,5	3,2	M4	1,5	17,000	3,2	1,6	290	3,0 × 10 <sup>-6</sup>	43	2,5	0,15	±0,4
SRBS-26	26,2	30	6,8	3,4	M4	1,5	15,000	4,2	2,1	350	8,6 × 10 <sup>-6</sup>	84	2,5	0,2	±0,4
SRBS-32	31,8	39	9,4	4,7	M5	2	12,000	7	3,5	840	2,5 × 10 <sup>-6</sup>	160	2,5	0,2	±0,4
SRBS-39	39	56	16	6	M5	2	9,500	16	8	1,000	8,4 × 10 <sup>-5</sup>	350	2,5	0,25	±0,4
SRBS-49	49	70	20	9,5	M6	4	7,000	32	16	1,400	2,8 × 10 <sup>-4</sup>	740	2,5	0,25	±0,5
SRBS-60	60	88	19	9	M8	8	6000	60	30	1800	8,6 × 10 <sup>-4</sup>	1370	2,5	0,3	±0,5

\* Please contact us about lead time of SRB-60 Series

## Standard Inner diameter

Product Number	Standard Inner diameter (d <sub>1</sub> , d <sub>2</sub> ) Standard INNER Diameter (mm)							
SRBS-12□	3×3	3×4	4×4	4×5	4,5×5	5×5		
SRBS-16□	3×3	4×4	4×5	4×6	4,5×5	4,5×6	5×5	5×6
	6×6							
SRBS-19□	4×4	4×5	5×5	5×6	5×8	6×6	6×6,35	6×8
	6,35×8	8×8						
SRBS-22□	5×5	5×6	6×6	6×6,35	6×8	6×10	6,35×8	6,35×10
	8×8	8×9,525	8×10	10×10				
SRBS-26□	5×5	6×6	6×6,35	6×8	6×10	6,35×8	6,35×10	8×8
	8×9,525	8×10	10×10	10×12	12×12			
SRBS-32□	6×6	6×8	6×10	6,35×8	8×8	8×9,525	8×10	8×12
	10×10	10×12	10×14	12×12	12×14	14×14	15×15	
SRB□S-39□	8×8	10×10	10×12	10×14	12×12	14×14	15×15	16×16
SRB□S-49□	12×14	14×14	14×16	15×15	16×16	18×18	20×20	
SRB□S-60□	15×15	16×16	18×18	20×20	22×22	24×24	25×25	

# SRB Series

## Micro Radial Beam Flexible Coupling

### SRBM(S) - ■ ■ C

[CLAMP TYPE]

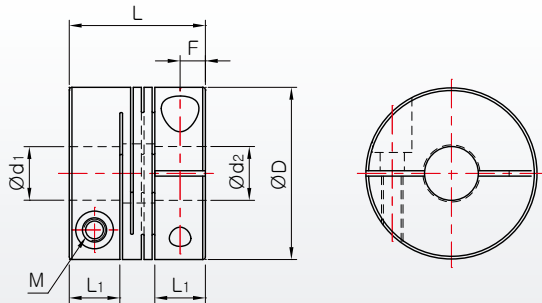

※ Material : High strength aluminum alloy (Al 7075-T6), Stainless

### SRBM - ■ ■

[SET SCREW TYPE]

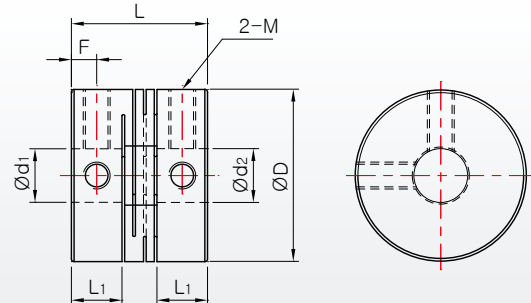

※ Material : High strength aluminum alloy (Al 7075-T6)

### Standards & Performance

Product Number	Dimension ( $\pm 0,3$ )				Fastening Bolt M	Fastening Torque (N · m)	Max-RPM ( $\text{min}^{-1}$ )	Max Torque (N · m)	Rated Torque (N · m)	Torsional Stiffness (N · m/rad)	Moment of Inertia ( $\text{kg} \cdot \text{m}^2$ )	Mass (g)	Errors of Misalignment		
	D	L	L <sub>1</sub>	F									Angle (°)	Parallel (mm)	End-Play (mm)
SRBM-12C	12,7	14	5	2,5	M2	0,5	20,000	0,4	0,2	60	$7,4 \times 10^{-8}$	3,2	1	0	0,15
SRBM-16C	16	16	6	3,0	M2,6	1	20,000	0,8	0,4	130	$2,9 \times 10^{-7}$	8,0	1	0	0,15
SRBM-19C	19,1	17	6,3	3,1	M2,6	1	19,000	1,2	0,6	160	$5,0 \times 10^{-7}$	10	1	0	0,15
SRBM-22C	22,2	20	7,4	3,7	M3	1,7	17,000	2,0	1,0	180	$1,1 \times 10^{-6}$	15	1	0	0,15
SRBM-26C	26,2	23	8,4	4,2	M3	1,7	15,000	3,0	1,5	480	$2,5 \times 10^{-6}$	25	1	0	0,15
SRBM-32C	31,8	30	11	5,5	M4	3,5	10,000	5,2	2,6	780	$7,5 \times 10^{-6}$	50	1	0	0,15
SRBMS-12C	12,7	14	5	2,5	M2	0,5	20,000	0,6	0,3	120	$2,4 \times 10^{-7}$	10	1	0	0,15
SRBMS-16C	16	16	6	3,0	M2,6	1	20,000	1,0	0,5	240	$7,0 \times 10^{-7}$	20	1	0	0,15
SRBMS-19C	19,1	17	6,3	3,1	M2,6	1	19,000	1,8	0,9	300	$1,5 \times 10^{-6}$	32	1	0	0,15
SRBMS-22C	22,2	20	7,4	3,7	M3	1,5	17,000	3,2	1,6	350	$3,1 \times 10^{-6}$	42	1	0	0,15
SRBMS-26C	26,2	23	8,4	4,2	M3	1,5	15,000	4,2	2,1	720	$7,2 \times 10^{-6}$	70	1	0	0,15
SRBMS-32C	31,8	30	11	5,5	M4	2,5	10,000	7,0	3,5	1,300	$2,0 \times 10^{-5}$	140	1	0	0,15
SRBM-12	12,7	13	4,5	2,2	M2,5	0,5	28,000	0,4	0,2	60	$7,4 \times 10^{-8}$	3,2	1	0	0,15
SRBM-16	16	14	5,0	2,5	M3	0,7	24,000	0,8	0,4	130	$2,9 \times 10^{-7}$	8,0	1	0	0,15
SRBM-19	19,1	17	6,3	3,1	M3	0,7	22,000	1,2	0,6	160	$5,0 \times 10^{-7}$	10	1	0	0,15
SRBM-22	22,2	19	6,9	3,4	M4	1,7	19,000	2,0	1,0	180	$1,1 \times 10^{-6}$	15	1	0	0,15
SRBM-26	26,2	22	7,9	3,9	M4	1,7	18,000	3,6	1,5	480	$2,5 \times 10^{-6}$	25	1	0	0,15
SRBM-32	31,8	29	10,5	5,2	M5	4	12,000	5,2	2,6	780	$7,5 \times 10^{-6}$	50	1	0	0,15

\* Please contact us about set screw type of SRBMS.

### Standard Inner diameter

Product Number	Standard Inner diameter (d <sub>1</sub> , d <sub>2</sub> ) Standard INNER Diameter (mm)												
	ø 2	ø 3	ø 4	ø 5	ø 6	ø 6,35	ø 8	ø 9,525	ø 10	ø 11	ø 12	ø 14	ø 15
SRBM(S)-12 □		●	●	●									
SRBM(S)-16 □		●	●	●	●								
SRBM(S)-19 □			●	●	●	●	●						
SRBM(S)-22 □				●	●	●	●	●	●				
SRBM(S)-26 □				●	●	●	●	●	●	●	●		
SRBM(S)-32 □					●	●	●	●	●	●	●	●	●

■ INNER diameter INCH type is also available  
 ■ We recommend that tolerance of shaft is H7.

■ Non standard inner diameter product is also available

■ KEY TYPE is also available



# SOH Series

## Zero Backlash Oldham Coupling



The major characteristic of OLDHAM COUPLING is that it provides exceptional flexibility and wide range of parallel and misalignment acceptability. Since there is no restoring force, there is little weight on bearing. Please, do not confuse with jaw coupling which are operated by different principle. Torque is transferred through disk that is capable of accepting misalignment error and mechanical intermittence. Replacement of disk is easy without disassembling hub from the shaft.

### Features

- Flexible movement - little weight on bearing
- High torsion rigidity
- Free from electro-magnetism
- Superior performance toward parallel, angular and misalignment
- Electricity insulation effect
- Low inertia
- Easy assembly

※ Registration of Design 152625  
 ※ Patent on a Device 12128

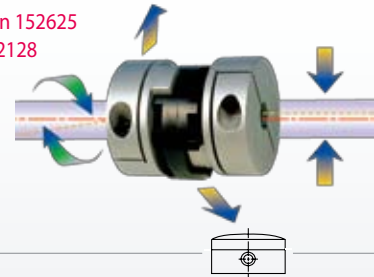

#### The past coupling

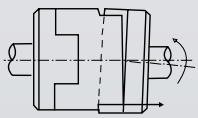

#### SUNGIL COUPLING



Micro rounding in the Hub accepts angular movement and lessens the load of shaft. Conventional OLDHAM coupling occurs bending moment in outer diameter for angular use. Therefore, it allows a little angular movement. SUNGIL OLDHAM coupling featuring micro rounding in the hub is designed for the angular disposition occurring in the center part. In consequence, angular allowance, lessen the shaft load transfer full torque.

### Proper installation of OLDHAM COUPLING

- Cascade layout should be avoided and proper bearing support is necessary
- OLDHAM coupling is not adequate for connecting moving shafts or used in pair



Right Use

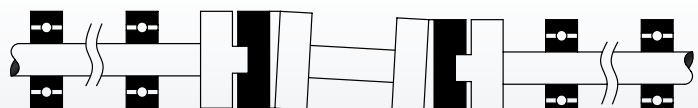

Wrong Use

### Misalignment

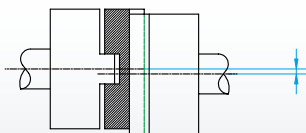

Parallel allowance :  $\pm$ mm

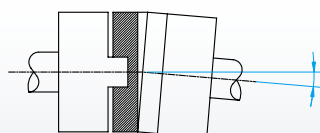

Angle allowance :  $\pm$ °

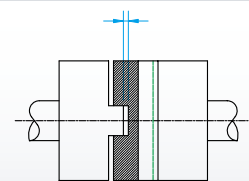

END-PLAY Angle allowance :  $\pm$ mm

### Application

- X-Y Position Table
- Good for small sized motor like AC motor, DC motor, Servo motor, Tacho generator and so forth
- Hydraulic distribution system and optical system
- Ventilation equipment, environmental equipment, encoder and small pump
- Paper, disk, tape transporting device

### Structure & Material

- Material : Polyacetal
- There is space through type

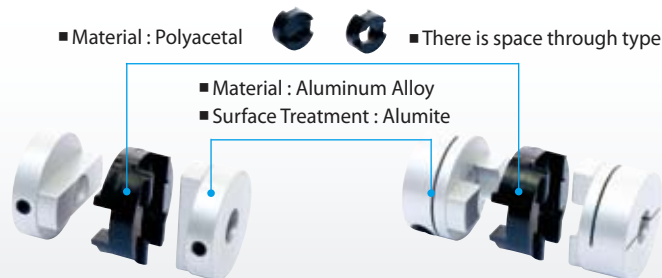

- Material : Aluminum Alloy
- Surface Treatment : Alumite

# SOH Series

## Zero Backlash Oldham Coupling

SOH - ■ ■ C

[CLAMP TYPE]

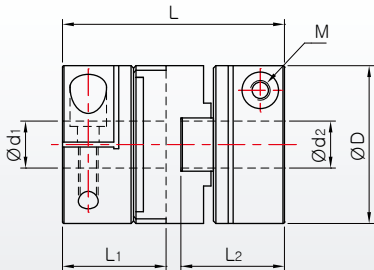

SOHM - ■ ■ C

[CLAMP TYPE]

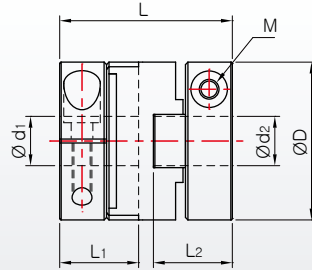

SOH - ■ ■

[SET SCREW TYPE]

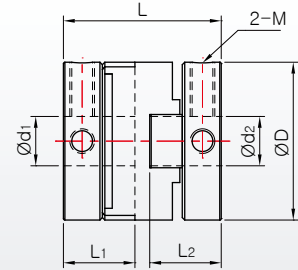

### Standards & Performance

Product Number	Dimension ( $\pm 0.3$ )				Fastening Bolt M	Fastening Torque (N·m)	Max. RPM ( $\text{min}^{-1}$ )	Max Torque (N·m)	Rated Torque (N·m)	Torsional Stiffness (N·m/rad)	Moment of Inertia ( $\text{kg} \cdot \text{m}^2$ )	Mass (g)	Errors of Misalignment		
	D	L	L <sub>1</sub>	L <sub>2</sub>									Angle (°)	Parallel (mm)	End-Play (mm)
SOH-16C	16	23.6	11	11	M2.6	1	8,000	2	1	65	$3.7 \times 10^{-7}$	10	1.5	1	0.1
SOH-20C	20	25.5	11.8	11.8	M2.6	1	7,000	3	1.5	120	$9.3 \times 10^{-7}$	16	1.5	1.5	0.1
SOH-25C	25.5	32	14.8	14.8	M3	1.7	6,000	5	2.5	200	$3.3 \times 10^{-6}$	34	1.5	2	0.1
SOH-32C	32	45	21	21	M4	3.5	4,800	14	7	620	$1.3 \times 10^{-5}$	80	1.5	2.5	0.2
SOH-43C	43	52	24	24	M5	8	4,000	30	15	1,200	$4.3 \times 10^{-5}$	160	1.5	3.0	0.2
SOH-53C	53	58	27	27	M5	8	3,400	50	25	1,400	$1.0 \times 10^{-4}$	252	1.5	3.2	0.2
SOH-57C	57	77	36.5	36.5	M6	13	3,200	72	36	2,600	$1.8 \times 10^{-4}$	390	1.5	3.5	0.2
SOHM-16C	16	21	9.5	9.5	M2.6	1	8,000	2	1	65	$3.2 \times 10^{-7}$	9	1.5	1	0.1
SOHM-20C	20	22.5	10	10	M2.6	1	7,000	3	1.5	120	$8.2 \times 10^{-7}$	14	1.5	1.5	0.1
SOHM-25C	25.5	27	12	12	M3	1.7	6,000	5	2.5	200	$2.6 \times 10^{-6}$	27	1.5	2	0.1
SOHM-32C	32	35	16	16	M4	3.5	4,800	14	7	620	$8.3 \times 10^{-6}$	52	1.5	2.5	0.2
SOHM-43C	43	47	21.2	21.2	M5	8	4,000	30	15	1,200	$2.0 \times 10^{-5}$	132	1.5	3.0	0.2
SOHM-53C	53	53	24.3	24.3	M5	8	3,400	50	25	1,400	$9.6 \times 10^{-5}$	235	1.5	3.2	0.2
SOHM-57C	57	56	26.7	26.7	M6	13	3,200	72	36	2,600	$1.3 \times 10^{-4}$	250	1.5	3.5	0.2
SOHM-70C	73	77	37	37	M8	30	3,000	130	65	4,800	$4.5 \times 10^{-4}$	450	1.5	3.5	0.2
SOH-16	16	18	8	8	M3	0.7	8,000	2	1	65	$2.4 \times 10^{-7}$	7	1.5	1	0.1
SOH-20	20	20	8.9	8.9	M4	1.7	7,000	3	1.5	120	$8.1 \times 10^{-7}$	14	1.5	1.5	0.1
SOH-25	25.5	25.5	11.6	11.6	M4	1.7	6,000	5	2.5	200	$1.8 \times 10^{-6}$	20	1.5	2	0.1
SOH-32	32	32	14.5	14.5	M5	4	4,800	14	7	620	$6.7 \times 10^{-6}$	48	1.5	2.5	0.2
SOH-43	43	52	24	24	M5	4	4,000	30	15	1,200	$3.9 \times 10^{-5}$	160	1.5	3.0	0.2
SOH-53	53	58	27	27	M6	7	3,400	50	25	1,400	$1.0 \times 10^{-4}$	252	1.5	3.2	0.2
SOH-57	57	77	36.5	36.5	M8	15	3,200	72	36	2,600	$1.8 \times 10^{-4}$	390	1.5	3.5	0.2
SOH-70	73	77	37	37	M8	15	3,000	130	65	4,800	$4.5 \times 10^{-4}$	450	1.5	3.5	0.2

※ Fastening Bolt is 1ea about SOH-16 and SOH-20

### How to order product



※ Please mark each inner diameter size.

※ Please mark through type in case of space through type when you order.

# SOH Series Zero Backlash Oldham Coupling

Please, download CAD DATA on [www.sungilfa.com](http://www.sungilfa.com)

## SOH - ■ ■ S [SET SCREW TYPE]

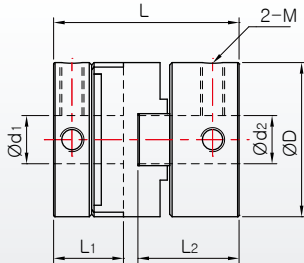

## SOH - ■ ■ SC [COMPLEX TYPE]

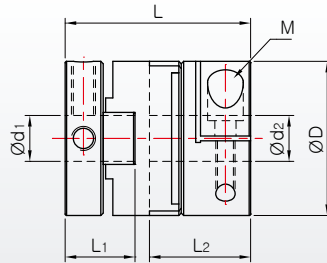

## SOH - ■ ■ SS [SET SCREW TYPE]

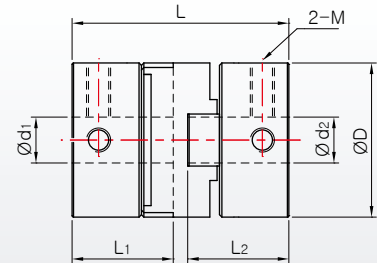

### Standards & Performance

Product Number	Dimension ( $\pm 0,3$ )				Fastening Bolt M	Fastening Torque (N · m)	Max. RPM ( $\text{min}^{-1}$ )	Max Torque (N · m)	Rated Torque (N · m)	Torsional Stiffness (N · m/rad)	Moment of Inertia ( $\text{kg} \cdot \text{m}^2$ )	Mass (g)	Errors of Misalignment		
	D	L	L <sub>1</sub>	L <sub>2</sub>									Angle (°)	Parallel (mm)	End-Play (mm)
SOH-16S	16	21	8	11	M3	0,7	8,000	2	1	65	$2,7 \times 10^{-7}$	10	1,5	1	0,1
SOH-20S	20	22,8	8,9	11,8	M4	1,7	7,000	3	1,5	120	$9,0 \times 10^{-7}$	15	1,5	1,5	0,1
SOH-25S	25,5	28,8	11,6	14,8	M4	1,7	6,000	5	2,5	200	$2,6 \times 10^{-6}$	30	1,5	2	0,1
SOH-32S	32	38,5	14,5	21	M5	4	4,800	14	7	620	$1,1 \times 10^{-5}$	65	1,5	2,5	0,2
SOH-16SC	16	21	8	11	M3/M2,6	0,7/1	8,000	2	1	65	$2,9 \times 10^{-7}$	7,5	1,5	1	0,1
SOH-20SC	20	22,8	8,9	11,8	M4/M2,6	1,7/1	7,000	3	1,5	120	$9,0 \times 10^{-7}$	15,5	1,5	1,5	0,1
SOH-25SC	25,5	28,8	11,6	14,8	M4/M3	1,7/1,7	6,000	5	2,5	200	$2,6 \times 10^{-6}$	27	1,5	2	0,1
SOH-32SC	32	38,5	14,5	21	M5/M4	4/3,5	4,800	14	7	620	$1,1 \times 10^{-5}$	70	1,5	2,5	0,2
SOH-16SS	16	23,6	11	11	M3	0,7	8,000	2	1	65	$2,3 \times 10^{-7}$	8	1,5	1	0,1
SOH-20SS	20	25,5	11,8	11,8	M4	1,7	7,000	3	1,5	120	$8,9 \times 10^{-7}$	14	1,5	1,5	0,1
SOH-25SS	25,5	32	14,8	14,8	M4	1,7	6,000	5	2,5	200	$1,8 \times 10^{-6}$	23	1,5	2	0,1
SOH-32SS	32	45	21	21	M5	4	4,800	14	7	620	$9,5 \times 10^{-6}$	41	1,5	2,5	0,2

### Standard Inner diameter

Product Number	Standard Inner diameter (d <sub>1</sub> , d <sub>2</sub> ) Standard INNER Diameter (mm)																								
	3	4	5	6	6,35	8	9,525	10	11	12	14	15	16	18	19	20	22	24	25	25,4	28	30	32	35	40
SOH□-16□□	●	●	●	●																					
SOH□-20□□		●	●	●	●	●																			
SOH□-25□□			●	●	●	●	●	●																	
SOH□-32□□				●	●	●	●	●	●	●	●	●													
SOH□-43□□						●	●	●	●	●	●	●	●	●	●										
SOH□-53□□								●	●	●	●	●	●	●	●	●	●	●	●						
SOH□-57□□												●	●	●	●	●	●	●	●	●	●	●			
SOH□-70□□														●	●	●	●	●	●	●	●	●	●	●	●

- INNER diameter INCH type is also available
  - Non standard inner diameter product is also available
  - KEY TYPE is also available
  - We recommend that tolerance of shaft is H7.
  - Please refer to following spacer through size.
- (SOH-16 =  $\varnothing 7,7$ , SOH-20 =  $\varnothing 10,7$ , SOH-25 =  $\varnothing 14,5$ , SOH-32 =  $\varnothing 16,5$ , SOH-43 =  $\varnothing 21,7$ , SOH-53 =  $\varnothing 25,7$ , SOH-70 =  $\varnothing 35,3$ )

## SOH - ■ ■



## SOH - ■ ■ SC



## SOH - ■ ■ S



## SOH - ■ ■ SS



# SOH Series

## SOH Big Series Zero Backlash Oldham Coupling

Please, download CAD DATA on [www.sungilfa.com](http://www.sungilfa.com)

### Features

- SOH Series Big size OLDHAM COUPLING
- Possible Inner Diameter Size :  $\varnothing 15 \sim \varnothing 60$
- High torque, High torsion rigidity
- Big parallel, angular, END-PLAY misalignment are absorbed simultaneously
- Double Clamp Type of Big Size
- Excellent balancing feature of perfect bilateral symmetry

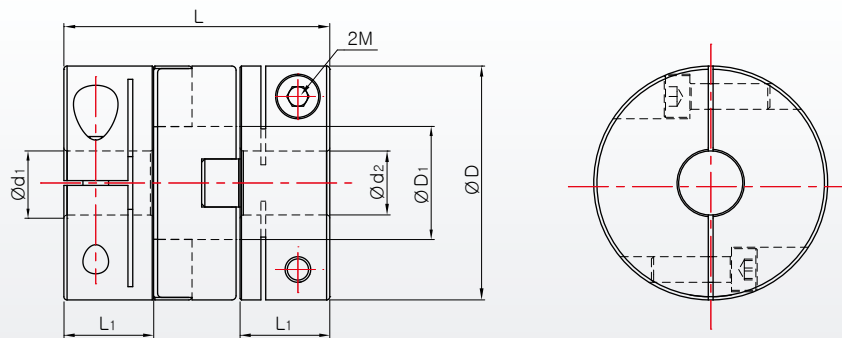

Please refer to following spacer through size.

- SOH-70C =  $\varnothing 35,3$
- SOH-90C =  $\varnothing 40,5$
- SOH-120C =  $\varnothing 50,5$

### Standards & Performance

Product Number	Dimension ( $\pm 0,3$ )				Fastening Bolt M	Fastening Torque (N · m)	Max. RPM ( $\text{min}^{-1}$ )	Max Torque (N · m)	Rated Torque (N · m)	Torsional Stiffness (N · m/rad)	Moment of Inertia ( $\text{kg} \cdot \text{m}^2$ )	Mass (g)	Errors of Misalignment		
	D	D <sub>1</sub>	L	L <sub>1</sub>									Angle (°)	Parallel (mm)	End-Play (mm)
SOH-70C	73	35,3	83	28	M8	30	3,000	130	65	2,000	$5,4 \times 10^{-4}$	670	1	5	0,4
SOH-90C	88	40,5	100	33,5	M10	50	2,800	210	105	2,500	$1,2 \times 10^{-3}$	1240	1	7	0,4
SOH-120C	118	50,5	141	40,5	M12	90	2,500	400	200	6,300	$6,5 \times 10^{-3}$	2600	1	7	0,6

### Standard Inner diameter

Product Number	Standard Inner diameter (d <sub>1</sub> , d <sub>2</sub> ) Standard INNER Diameter (mm)																					
	$\varnothing 15$	$\varnothing 16$	$\varnothing 18$	$\varnothing 19$	$\varnothing 20$	$\varnothing 22$	$\varnothing 24$	$\varnothing 25$	$\varnothing 28$	$\varnothing 30$	$\varnothing 32$	$\varnothing 34$	$\varnothing 35$	$\varnothing 40$	$\varnothing 42$	$\varnothing 45$	$\varnothing 50$	$\varnothing 52$	$\varnothing 55$	$\varnothing 58$	$\varnothing 60$	
SOH-70C	●	●	●	●	●	●	●	●	●	●	●	●	●	●								
SOH-90C	●	●	●	●	●	●	●	●	●	●	●	●	●	●	●	●	●					
SOH-120C								●	●	●	●	●	●	●	●	●	●	●	●	●	●	●

- INNER diameter INCH type is also available
- Non standard inner diameter product is also available

# SD Series

## Zero Backlash Disk Coupling



DISK COUPLING of SI is built-in coupling which provides big torsion rigidity and superior mobility, and it is high precision coupling that has nearly permanent lifespan.

DISK COUPLING of SI can rotate with high speed in one or two directions and is often used mainly in high-precision measuring equipments, high speed movement control system, critical weight, dynamometer, precision encoder and so forth.

### Features

- Designed with high torsion rigidity
- Not affected by backlash and has semi permanent lifespan
- Accept amplitude, eccentricity and misalignment between shafts
- Single-stage and double-stage types
- Built-in metal structure
- Low inertia
- High-precision position controlling system
- Identical regular and reverse rotational characteristics
- Maintenance free and excellent resistance against oil

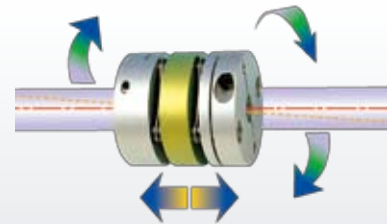

### Allowance Parallel applying float shaft

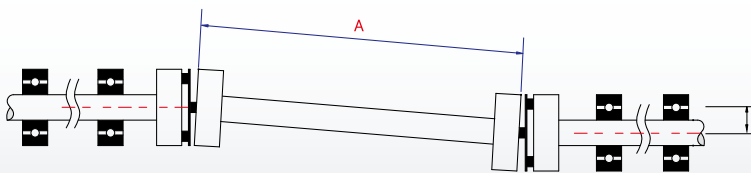

Allowance Parallel B  $B = A \times \sin \theta$   
 Here, A : Float shaft length  
 $\theta$  : Allowance Angle of Coupling

### Misalignment

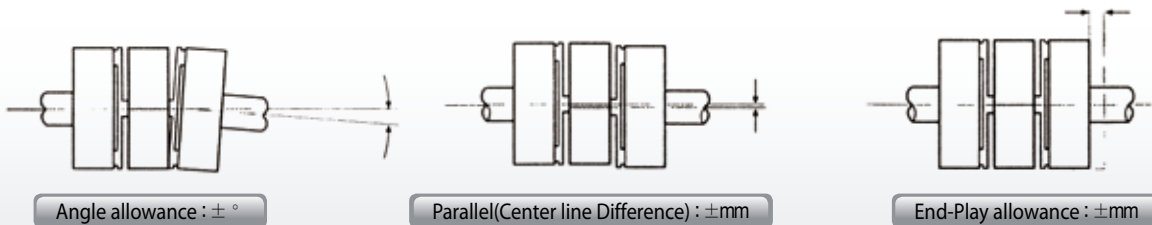

### Application

- Servo motor, stepping motor, precision motor and so forth
- High precision encoder and dynamometer drive
- High speed and high precision position controlling system, centrifugal separator
- Copy machine, information, communication and audio equipment

### Structure & Material

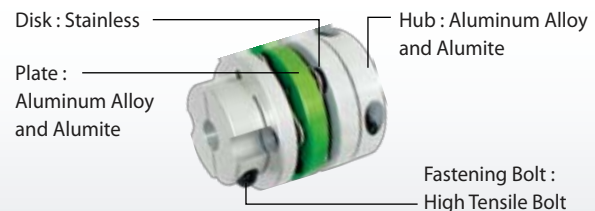

### How to order product

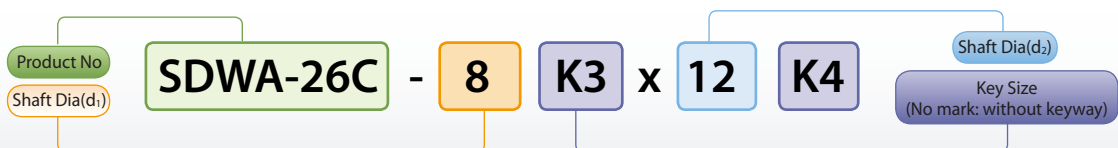

- ※ Please mark each inner diameter size.
- ※ It is impossible for you to ask additional keyway process and change inner dia size after order SI disk coupling.
- ※ When you assemble your machinery by our coupling, please disassemble our disk coupling arbitrarily because of SI dick coupling is assembled by optimal situation.

# SD Series

## Zero Backlash Disk Coupling

### SDS - ■ ■ ■

[SET SCREW TYPE]

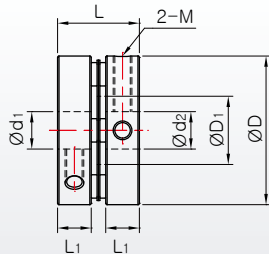

### SD ■ S - ■ ■ ■ C

[CLAMP TYPE]

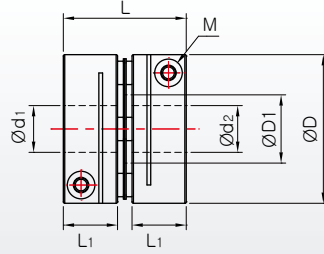

### SDCS-54C

[CLAMP TYPE]

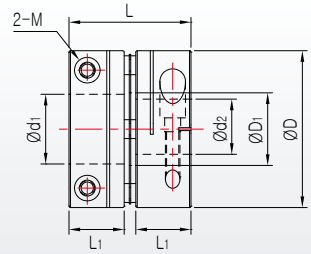

### Standards & Performance

Product Number	Dimension ( $\pm 0.3$ )				Fastening Bolt M	Fastening Torque (N · m)	Max. RPM ( $\text{min}^{-1}$ )	Max Torque (N · m)	Rated Torque (N · m)	Torsional Stiffness (N · m/rad)	Moment of Inertia ( $\text{kg} \cdot \text{m}^2$ )	Mass (g)	Errors of Misalignment		
	D	D <sub>1</sub>	L	L <sub>1</sub>									Angle (°)	Parallel (mm)	End-Play (mm)
SDS-16	16	6,2	11,9	5,1	M2,5	0,5	12,000	1	0,5	270	$1,8 \times 10^{-7}$	5	1	0	0,1
SDS-16C	16	6,2	17,4	7,8	M2	0,5	10,000	1	0,5	270	$2,6 \times 10^{-7}$	7	1	0	0,1
SDS-19	19	8,2	14	6,1	M3	0,7	12,000	1,8	0,9	500	$3,0 \times 10^{-7}$	6	1	0	0,1
SDS-19C	19	8,2	19,2	8,7	M2,5	1	10,000	1,8	0,9	500	$4,0 \times 10^{-7}$	8	1	0	0,1
SDS-22	22,2	9	14,7	6,2	M3	0,7	12,000	2,2	1,1	600	$6,9 \times 10^{-7}$	10	1	0	0,1
SDS-22C	22,2	9	19,6	8,7	M2,5	1	10,000	2,2	1,1	600	$1,0 \times 10^{-6}$	15	1	0	0,1
SDS-26	26,2	12,2	17,5	7,5	M4	1,7	10,000	3	1,5	900	$2,0 \times 10^{-6}$	20	1	0	0,15
SDS-26C	26,2	12,2	24,1	10,7	M3	1,7	9,000	3	1,5	900	$2,4 \times 10^{-6}$	15	1	0	0,15
SDS-31	31,8	14,5	17,5	7,2	M4	1,7	9,000	6	3	1,700	$4,4 \times 10^{-6}$	30	1	0	0,2
SDS-31C	31,8	14,5	26,5	11,6	M3	1,7	8,500	6	3	1,700	$5,8 \times 10^{-6}$	40	1	0	0,2
SDS-39C	39	13,6	31,2	13,6	M4	3,5	8,000	10	5	2,300	$1,6 \times 10^{-5}$	70	1	0	0,2
SDCS-42C	42,5	18	31,4	13,6	M4	3,5	8,000	12	6	2,800	$3,4 \times 10^{-5}$	95	1	0	0,2
SDCS-47C	47	20,4	41,4	16	M4	3,5	7,000	20	10	6,000	$5,4 \times 10^{-5}$	140	1	0	0,2
SDCS-54C	54	25	42,4	19	M5	8	6,000	44	22	11,000	$9,8 \times 10^{-5}$	200	1	0	0,2

### SDW ■ - ■ ■ ■

[SET SCREW TYPE]

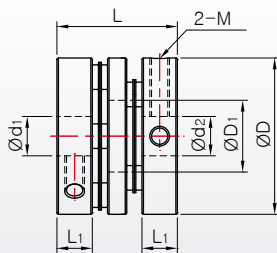

### SDW ■ - ■ ■ ■ C

[CLAMP TYPE]

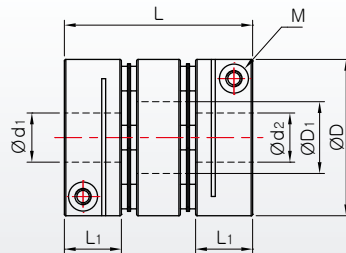

### Standards & Performance

Product Number	Dimension ( $\pm 0.3$ )				Fastening Bolt M	Fastening Torque (N · m)	Max. RPM ( $\text{min}^{-1}$ )	Max Torque (N · m)	Rated Torque (N · m)	Torsional Stiffness (N · m/rad)	Moment of Inertia ( $\text{kg} \cdot \text{m}^2$ )	Mass (g)	Errors of Misalignment		
	D	D <sub>1</sub>	L	L <sub>1</sub>									Angle (°)	Parallel (mm)	End-Play (mm)
SDWA-16	16	6,2	15,6	5,1	M2,5	0,5	12,000	1	0,5	200	$2,2 \times 10^{-7}$	6	3	0,2	0,2
SDWB-16	16	6,2	17,6	5,1	M2,5	0,5	12,000	1	0,5	200	$2,6 \times 10^{-7}$	7	3	0,2	0,2
SDWA-16C	16	6,2	21	7,8	M2	1	10,000	1	0,5	200	$3,3 \times 10^{-7}$	9	3	0,2	0,2
SDWB-16C	16	6,2	23	7,8	M2	1	10,000	1	0,5	200	$3,7 \times 10^{-7}$	10	3	0,2	0,2
SDWA-19	19	8,2	18	6,1	M3	0,7	12,000	1,8	0,9	300	$5,3 \times 10^{-7}$	10	3	0,2	0,2
SDWB-19	19	8,2	21	6,1	M3	0,7	12,000	1,8	0,9	300	$5,8 \times 10^{-7}$	11	3	0,2	0,2
SDWA-19C	19	8,2	23	8,7	M2,6	1	10,000	1,8	0,9	300	$7,4 \times 10^{-7}$	14	3	0,2	0,2
SDWB-19C	19	8,2	26,2	8,7	M2,6	1	10,000	1,8	0,9	300	$7,9 \times 10^{-7}$	15	3	0,2	0,2

# SD Series Zero Backlash Disk Coupling

Please, download CAD DATA on [www.sungilfa.com](http://www.sungilfa.com)

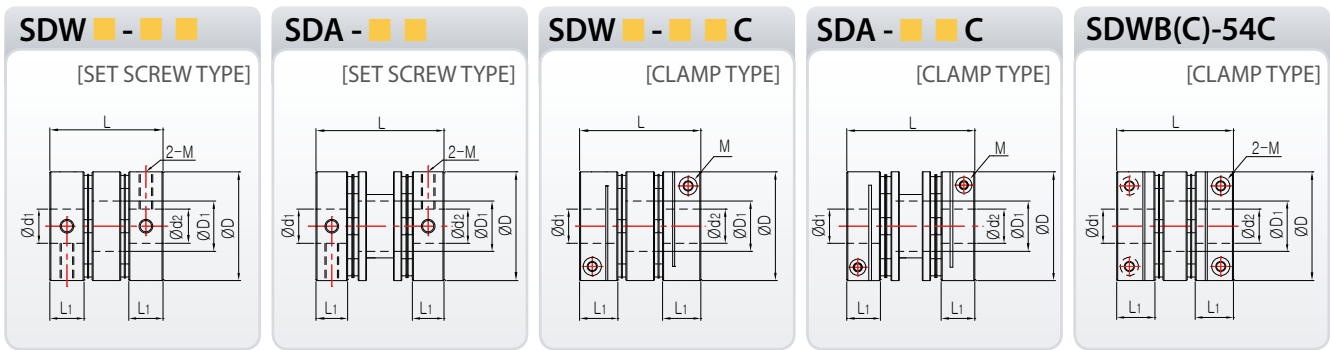

## Standards & Performance

Product Number	Dimension ( $\pm 0.3$ )				Fastening Bolt M	Fastening Torque (N · m)	Max-RPM ( $\text{min}^{-1}$ )	Max Torque (N · m)	Rated Torque (N · m)	Torsional Stiffness (N · m/rad)	Moment of Inertia ( $\text{kg} \cdot \text{m}^2$ )	Mass (g)	Errors of Misalignment		
	D	D <sub>1</sub>	L	L <sub>1</sub>									Angle (°)	Parallel (mm)	End-Play (mm)
SDWA-22	22,2	9	20	6,2	M3	0,7	12,000	2,2	1,1	400	$1,0 \times 10^{-6}$	16	3	0,2	0,2
SDWB-22	22,2	9	22,2	6,2	M3	0,7	12,000	2,2	1,1	400	$1,1 \times 10^{-6}$	17	3	0,3	0,2
SDA-22	22,2	8,3	28,2	6,2	M3	0,7	12,000	2,2	1,1	400	$1,3 \times 10^{-6}$	18	3	0,4	0,2
SDWA-22C	22,2	9	25	8,7	M2,6	1	10,000	2,2	1,1	400	$1,3 \times 10^{-6}$	18	3	0,2	0,2
SDWB-22C	22,2	9	27	8,7	M2,6	1	10,000	2,2	1,1	400	$1,4 \times 10^{-6}$	19	3	0,3	0,2
SDA-22C	22,2	8,3	33	8,7	M2,6	1	10,000	2,2	1,1	400	$1,5 \times 10^{-6}$	20	3	0,4	0,2
SDWA-26	26,6	12,2	26	7,3	M4	1,7	10,000	3	1,5	600	$2,3 \times 10^{-6}$	28	3	0,3	0,3
SDA-26	26,6	10,5	31,5	7,3	M4	1,7	10,000	3	1,5	600	$3,2 \times 10^{-6}$	32	3	0,4	0,3
SDWA-26C	26,6	12,2	32,6	10,7	M3	1,7	9,000	3	1,5	600	$3,4 \times 10^{-6}$	34	3	0,3	0,3
SDA-26C	26,6	10,5	38,5	10,7	M3	1,7	9,000	3	1,5	600	$3,9 \times 10^{-6}$	39	3	0,4	0,3
SDWA-31	31,8	14,5	24,5	7,2	M4	1,7	9,000	6	3	1,300	$4,3 \times 10^{-6}$	30	3	0,2	0,4
SDWB-31	31,8	14,5	29,5	7,2	M4	1,7	9,000	6	3	1,300	$5,5 \times 10^{-6}$	38	3	0,3	0,4
SDA-31	31,8	12,5	36	7,2	M4	1,7	9,000	6	3	1,300	$5,5 \times 10^{-6}$	38	3	0,4	0,4
SDWA-31C	31,8	14,5	33,5	11,6	M3	1,7	8,500	6	3	1,300	$7,5 \times 10^{-6}$	52	3	0,2	0,4
SDWB-31C	31,8	14,5	38,5	11,6	M3	1,7	8,500	6	3	1,300	$8,8 \times 10^{-6}$	60	3	0,3	0,4
SDA-31C	31,8	12,5	44,7	11,6	M3	1,7	8,500	6	3	1,300	$8,8 \times 10^{-6}$	60	3	0,4	0,4
SDWA-39C	39	17	39	13,6	M4	3,5	8,000	10	5	1,800	$2,1 \times 10^{-5}$	95	3	0,2	0,4
SDWC-39C	39	17	44,8	13,6	M4	3,5	8,000	10	5	1,800	$2,4 \times 10^{-5}$	110	3	0,3	0,4
SDA-39C	39	17	56,2	13,6	M4	3,5	8,000	10	5	1,800	$3,0 \times 10^{-5}$	120	3	0,4	0,4
SDWC-42C	42,5	18	46	13,6	M4	3,5	8,000	12	6	2,000	$3,3 \times 10^{-5}$	120	3	0,3	0,5
SDWC-47C	47	20,4	50	16	M4	3,5	7,000	20	10	4,000	$5,5 \times 10^{-5}$	160	3	0,4	0,5
SDWB-54C	54	25	52	19	M5	8	6,000	44	22	7,000	$1,1 \times 10^{-4}$	250	3	0,3	0,5
SDWC-54C	54	25	58	19	M5	8	6,000	44	22	7,000	$1,2 \times 10^{-4}$	280	3	0,4	0,5

## Standard Inner diameter

Product Number	Standard Inner diameter (d <sub>1</sub> , d <sub>2</sub> ) Standard INNER Diameter (mm)																								
	3	4	4,5	5	6	6,35	7	8	9	9,525	10	11	12	12,7	14	15	15,875	16	17	18	19	20	24	25	
SD □ □ -16 □	●	●	●	●																					
SD □ □ -19 □	●	●	●	●	●																				
SD □ □ -22 □	●	●	●	●	●	●	●	●	★	●	★	●	★												
SD □ □ -26 □		●	●	●	●	●	●	●	●	●	●														
SD □ □ -31 □				●	●	●	●	●	●	●	●	●	●	●	●	★									
SD □ □ -39 □				●	●	●	●	●	●	●	●	●	●	●	●	●	●	●	●						
SD □ □ -42C					●	●	●	●	●	●	●	●	●	●	●	●	●	●	●	●	★	●	★		
SD □ □ -47C							●	●	●	●	●	●	●	●	●	●	●	●	●	●	●	●	●		
SD □ □ -54 □											●	●	●	●	●	●	●	●	●	●	●	●	●		

- INNER diameter INCH type is also available
- Non standard inner diameter product is also available
- We recommend that tolerance of shaft is H7.
- KEY TYPE is also available
- Inner diameter size of SDWA-□ □ is same with SDWB-□ □
- ★ The inner diameter that is marked ★ is not available by shaft through type

# SD Series

## Zero Backlash Disk Coupling

### SDS - ■ ■ C

[CLAMP TYPE]

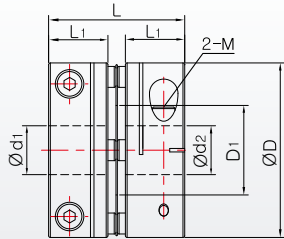

### SDW - ■ ■ C

[CLAMP TYPE]

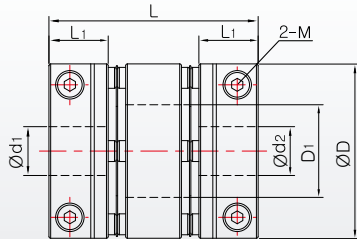

### SDA - ■ ■ C

[CLAMP TYPE]

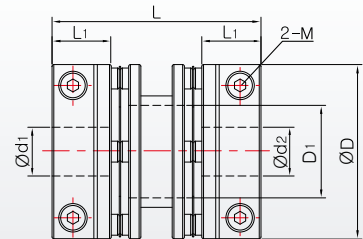

### Standards & Performance

Product Number	Dimension ( $\pm 0.3$ )				Fastening Bolt M	Fastening Torque (N · m)	Max. RPM ( $\text{min}^{-1}$ )	Max Torque (N · m)	Rated Torque (N · m)	Torsional Stiffness (N · m/rad)	Moment of Inertia ( $\text{kg} \cdot \text{m}^2$ )	Mass (g)	Errors of Misalignment		
	D	D <sub>1</sub>	L	L <sub>1</sub>									Angle (°)	Parallel (mm)	End-Play (mm)
SDS-80C	80	35	66.8	30	M8	30	6,000	150	75	32,000	$7.5 \times 10^{-4}$	800	2	0	0.3
SDW-80C	80	35	82.5	30	M8	30	6,000	150	75	16,000	$8.4 \times 10^{-4}$	900	2	0.4	0.6
SDA-80C	80	32	98.5	30	M8	30	6,000	150	75	16,000	$9.5 \times 10^{-4}$	1,000	2	0.5	0.6
SDS-90C	94.5	41.6	68.5	30.4	M8	30	6,000	300	150	150,000	$1.2 \times 10^{-3}$	930	2	0	0.4
SDW-90C	94.5	41.6	98	30.4	M8	30	6,000	300	150	70,000	$1.8 \times 10^{-3}$	1,350	2	0.4	0.8
SDS-100C	104.5	47	71	30.6	M8	30	6,000	440	220	200,000	$2.2 \times 10^{-3}$	1,300	2	0	0.4
SDW-100C	104.5	47	102.5	30.6	M8	30	6,000	440	220	100,000	$2.9 \times 10^{-3}$	1,700	2	0.4	0.8

### Standard Inner diameter

Product Number	Standard Inner diameter (d <sub>1</sub> , d <sub>2</sub> ) Standard INNER Diameter (mm)															
	15	16	18	19	20	22	24	25	28	30	32	35	40	45	50	50
SDS-80C	●	●	●	●	●	●	●	●	●	●	●					
SDW-80C	●	●	●	●	●	●	●	●	●	●	●					
SDS-90C					●	●	●	●	●	●	●	●	●			
SDW-90C					●	●	●	●	●	●	●	●	●	●		
SDS-100C					●	●	●	●	●	●	●	●	●	●	●	★
SDW-100C					●	●	●	●	●	●	●	●	●	●	●	★

- INNER diameter INCH type is also available
- We recommend that tolerance of shaft is H7.

- Non standard inner diameter product is also available

- KEY TYPE is also available

The inner diameter that is marked ★ is not available by shaft through type

SDS - ■ ■ C    SDWA - ■ ■ C    SDWB - ■ ■ C    SDWC - ■ ■ C    SDAA - ■ ■ C    SDAB - ■ ■ C    SDAC - ■ ■ C



※ Hub design can be changed according to diameter size



# SD Series Zero Backlash Disk Coupling

Please, download CAD DATA on [www.sungilfa.com](http://www.sungilfa.com)

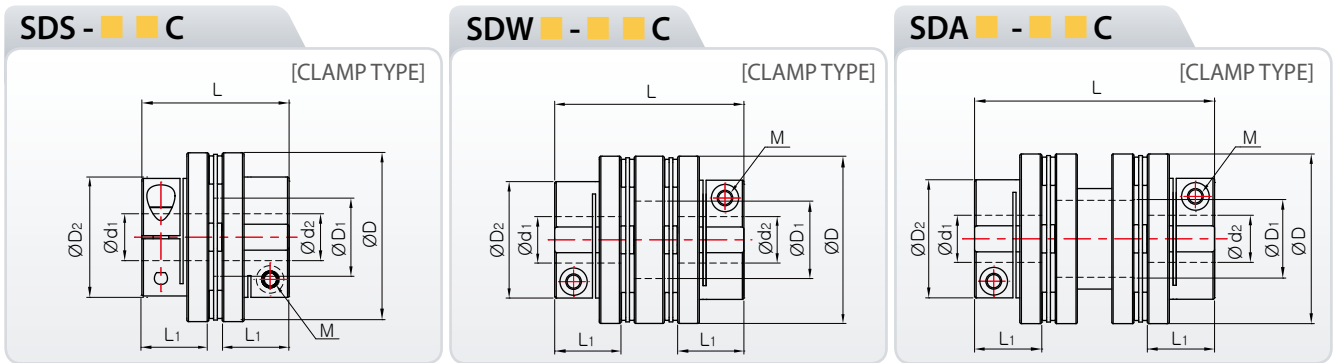

## Standards & Performance

Product Number	Dimension ( $\pm 0.3$ )					Fastening Bolt M	Fastening Torque (N · m)	Max-RPM (min <sup>-1</sup> )	Max Torque (N · m)	Rated Torque (N · m)	Torsional Stiffness (N · m/rad)	Moment of Inertia (kg · m <sup>2</sup> )	Mass (g)	Errors of Misalignment		
	D	D <sub>1</sub>	D <sub>2</sub>	L	L <sub>1</sub>									Angle (°)	Parallel (mm)	End-Play (mm)
SDS-42C	42,5	18	29,2	31	13,5	M3	1,7	8,000	12	6	2,800	$1,7 \times 10^{-5}$	65	1,5	0	0,2
SDWA-42C	42,5	18	29,2	39,7	13,5	M3	1,7	8,000	12	6	2,000	$2,1 \times 10^{-5}$	84	3	0,2	0,5
SDWB-42C	42,5	18	29,2	44,2	13,5	M3	1,7	8,000	12	6	2,000	$2,4 \times 10^{-5}$	94	3	0,3	0,5
SDAA-42C	42,5	18	29,2	50	13,5	M3	1,7	8,000	12	6	2,000	$2,7 \times 10^{-5}$	105	3	0,4	0,5
SDAB-42C	42,5	18	29,2	58	13,5	M3	1,7	8,000	12	6	2,000	$2,8 \times 10^{-5}$	110	3	0,5	0,5
SDAC-42C	42,5	18	29,2	67,2	13,5	M3	1,7	8,000	12	6	2,000	$2,9 \times 10^{-5}$	115	3	0,6	0,5
SDS-47C	47	20,4	33	37	16,7	M4	3,5	7,500	20	10	6,000	$3,2 \times 10^{-5}$	108	1,5	0	0,2
SDWA-47C	47	20,4	33	45,5	16,7	M4	3,5	7,500	20	10	4,000	$3,6 \times 10^{-5}$	120	3	0,2	0,5
SDWB-47C	47	20,4	33	51,3	16,7	M4	3,5	7,500	20	10	4,000	$3,9 \times 10^{-5}$	132	3	0,4	0,5
SDAA-47C	47	20	33	63,7	16,7	M4	3,5	7,500	20	10	4,000	$4,5 \times 10^{-5}$	152	3	0,5	0,5
SDAB-47C	47	20	33	90,5	16,7	M4	3,5	7,500	20	10	4,000	$5,1 \times 10^{-5}$	172	3	0,8	0,5
SDS-54C	54	25	38,5	47	21,5	M5	8	7,000	44	22	11,000	$5,5 \times 10^{-5}$	145	1,5	0	0,2
SDWA-54C	54	25	38,5	60,5	21,5	M5	8	7,000	44	22	7,000	$7,2 \times 10^{-5}$	192	3	0,2	0,5
SDAA-54C	54	24	38,5	75,6	21,5	M5	8	7,000	44	22	7,000	$9,0 \times 10^{-5}$	240	3	0,5	0,5
SDAB-54C	54	24	38,5	89,5	21,5	M5	8	7,000	44	22	7,000	$1,1 \times 10^{-4}$	266	3	0,7	0,5
SDS-64C	64	25,5	48	58	26	M6	13	6,500	62	31	20,000	$1,8 \times 10^{-4}$	292	1,5	0	0,2
SDWA-64C	64	25,5	48	74	26	M6	13	6,500	62	31	11,000	$2,2 \times 10^{-4}$	373	3	0,3	0,5
SDA-64C	64	25,5	48	89,5	26	M6	13	6,500	62	31	20,000	$2,7 \times 10^{-4}$	450	3	0,5	0,5

## Standard Inner diameter

Product Number	Standard Inner diameter (d <sub>1</sub> , d <sub>2</sub> ) Standard INNER Diameter (mm)																											
	5	6	6,35	7	8	9	9,525	10	11	12	12,7	14	15	15,875	16	17	18	19	20	21	22	24	25	26	28	30	35	
SD □ □ -42C	●	●	●	●	●	●	●	●	●	●	●	●	●															
SD □ □ -47C					●	●	●	●	●	●	●	●	●	●	●	●	●	●	●	●								
SD □ □ -54C									●	●	●	●	●	●	●	●	●	●	●	●								
SD □ □ -64C										●	●	●	●	●	●	●	●	●	●	●	●	●	●	●	●	●	●	●

- INNER diameter INCH type is also available
- Non standard inner diameter product is also available
- We recommend that tolerance of shaft is H7.
- KEY TYPE is also available
- Inner diameter size of SDWA-□□ is same with SDWB-□□
- ★ The inner diameter that is marked ★ is not available by shaft through type

# SD Series

## Zero Backlash Disk Coupling

### SDS - ■ ■ ■

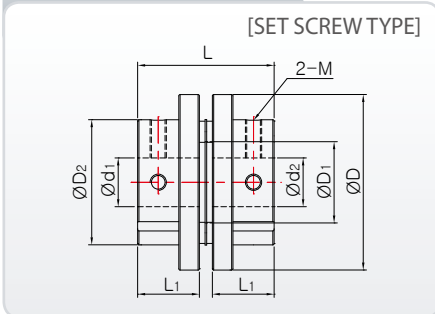

### SDW ■ ■ ■

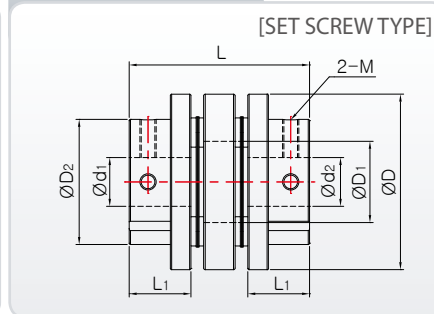

### SDA ■ ■ ■

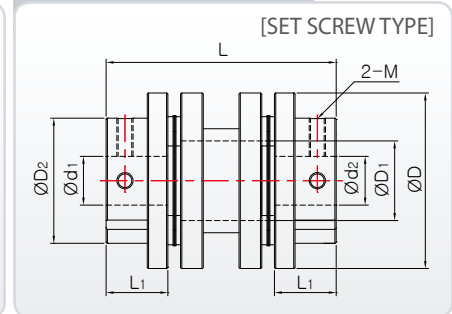

### Standards & Performance

Product Number	Dimension (±0,3)					Fastening Bolt M	Fastening Torque (N·m)	Max-RPM (min <sup>-1</sup> )	Max Torque (N·m)	Rated Torque (N·m)	Torsional Stiffness (N·m/rad)	Moment of Inertia (kg·m <sup>2</sup> )	Mass (g)	Errors of Misalignment		
	D	D <sub>1</sub>	D <sub>2</sub>	L	L <sub>1</sub>									Angle (°)	Parallel (mm)	End-Play (mm)
SDS-42	42,5	18	29,2	31	13,5	M4	1,7	8,000	12	6	2,800	1,7 × 10 <sup>-5</sup>	65	1,5	0	0,2
SDWA-42	42,5	18	29,2	39,7	13,5	M4	1,7	8,000	12	6	2,000	2,1 × 10 <sup>-5</sup>	84	3	0,2	0,5
SDWB-42	42,5	18	29,2	44,2	13,5	M4	1,7	8,000	12	6	2,000	2,4 × 10 <sup>-5</sup>	94	3	0,3	0,5
SDAA-42	42,5	18	29,2	50	13,5	M4	1,7	8,000	12	6	2,000	2,7 × 10 <sup>-5</sup>	105	3	0,4	0,5
SDAB-42	42,5	18	29,2	58	13,5	M4	1,7	8,000	12	6	2,000	2,8 × 10 <sup>-5</sup>	110	3	0,5	0,5
SDAC-42	42,5	18	29,2	67,2	13,5	M4	1,7	8,000	12	6	2,000	2,9 × 10 <sup>-5</sup>	115	3	0,6	0,5
SDS-47	47	20,4	33	31,7	14	M5	4	8,000	20	10	6,000	2,7 × 10 <sup>-5</sup>	91	1,5	0	0,2
SDWA-47	47	20,4	33	40	14	M5	4	8,000	20	10	4,000	3,4 × 10 <sup>-5</sup>	115	3	0,2	0,5
SDWB-47	47	20,4	33	46	14	M5	4	8,000	20	10	4,000	3,6 × 10 <sup>-5</sup>	120	3	0,4	0,5
SDAA-47	47	20	33	58,5	14	M5	4	8,000	20	10	4,000	4,2 × 10 <sup>-5</sup>	140	3	0,5	0,5
SDAB-47	47	20	33	85	14	M5	4	8,000	20	10	4,000	4,7 × 10 <sup>-5</sup>	160	3	0,8	0,5
SDS-54	54	25	38,5	42,2	19	M5	4	7,500	44	22	11,000	4,9 × 10 <sup>-5</sup>	130	1,5	0	0,2
SDWA-54	54	25	38,5	55,5	19	M5	4	7,500	44	22	7,000	6,7 × 10 <sup>-5</sup>	177	3	0,2	0,5
SDAA-54	54	24	38,5	71	19	M5	4	7,500	44	22	7,000	9,0 × 10 <sup>-5</sup>	230	3	0,5	0,5
SDAB-54	54	24	38,5	85	19	M5	4	7,500	44	22	7,000	1,1 × 10 <sup>-4</sup>	250	3	0,7	0,5
SDS-64	64	25,5	48	58	26	M8	15	7,000	62	31	20,000	1,8 × 10 <sup>-4</sup>	292	1,5	0	0,2
SDWA-64	64	25,5	48	74	26	M8	15	7,000	62	31	11,000	2,2 × 10 <sup>-4</sup>	373	3	0,3	0,5
SDA-64	64	25,5	48	89,5	26	M8	15	7,000	62	31	11,000	2,7 × 10 <sup>-4</sup>	450	3	0,5	0,5

### Standard Inner diameter

Product Number	Standard Inner diameter (d <sub>1</sub> , d <sub>2</sub> ) Standard INNER Diameter (mm)																												
	5	6	6,35	7	8	9	9,525	10	11	12	12,7	14	15	15,875	16	17	18	19	20	21	22	24	25	26	28	30	35		
SD□□-42		●	●	●	●	●	●	●	●	●	●	●	●																
SD□□-47					●	●	●	●	●	●	●	●	●	●	●	●	●	●	●										
SD□□-54								●	●	●	●	●	●	●	●	●	●	●	●	●									
SD□□-64										●	●	●	●	●	●	●	●	●	●	●	●	●	●	●	●	●	●	●	●

■ INNER diameter INCH type is also available  
 ■ We recommend that tolerance of shaft is H7.

■ Non standard inner diameter product is also available

■ KEY TYPE is also available

The inner diameter that is marked ★ is not available by shaft through type

# SHD Series

## High Torque Flexible Disk Coupling



## New Ideal and Best Suited Design!! Ideal-Realization of Servo System

New developed flexible disk coupling realized the servo system perfectly by securing the flexibility and increase the number of mounting hole and maximizing the mobility space of sus disk plate.

We consider each component most carefully and make the disk together with bush by one package in order to long life time of disk.

The outside diameter size of bush is bigger than outside diameter size of hole and disk shape is similar with shape of R. so this product has durability about big torsion because of these features. New flexible disk coupling is constructed by package of some sus disk and bush. This product is protected from load and the form of disk is not changed by making into one package.

We assemble new flexible disk coupling perfectly.

We measure and adjust concentricity every process so new flexible disk coupling of SI is assembled completely by adjusting concentricity perfectly.

There is a hole in outside diameter part in order to assemble easily and prevent the coupling moving when you assembly the taper clamp type

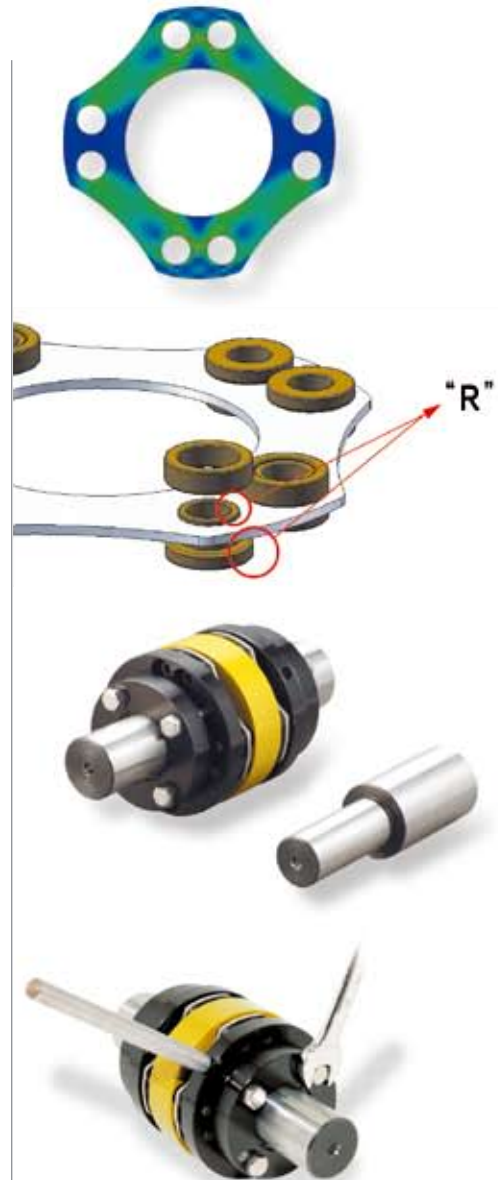

### Material

AL 7075-T6 and Anodizing

### AL 7075-T6 and Anodizing

- Application of new developed and high quality disk file
- Compact Design
- High Speed
- High Torque
- High Torsion Rigidity
- Zero Backlash
- Low Inertia Moment
- Retain of 1/10 Taper Bushing

### How to order product

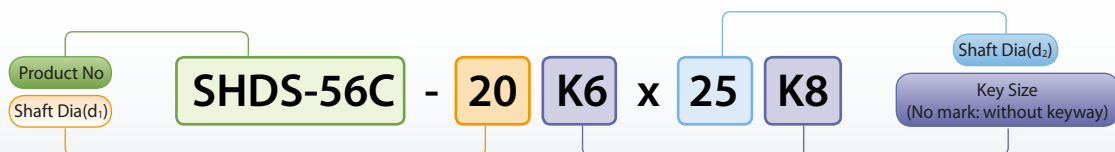

※ Please mark each inner diameter size.

# SHD Series

## High Torque Flexible Disk Coupling

SHDS - ■ ■ ■ C

[CLAMP TYPE]

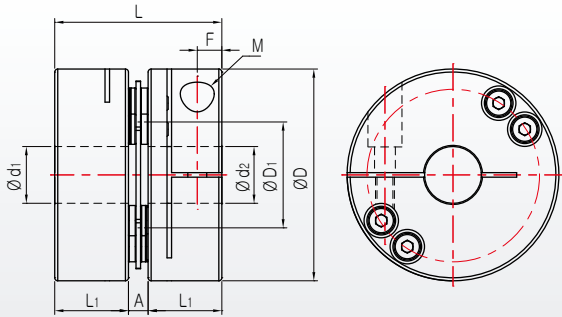

SHDW - ■ ■ ■ C

[CLAMP TYPE]

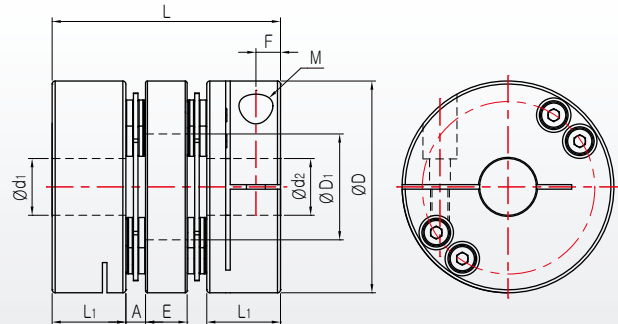

### Standards & Performance

Product Number	SHDS - 56C	SHDW - 56C	SHDS - 66C	SHDW - 66C	SHDS - 88C	SHDW - 88C
∅ D	56	56	66	66	88	88
∅ d <sub>1</sub> , d <sub>2</sub>	10 ~ 25	10 ~ 25	15 ~ 32	15 ~ 32	20 ~ 45	20 ~ 45
L <sub>1</sub>	19,5	19,5	24,5	24,5	30	30
A	5,2	5,2	7,5	7,5	9,6	9,6
L	44,2	60,5	56,5	80	69,5	99,2
F	6,5	6,5	7	7	9	9
∅ D <sub>1</sub>	28	28	33	33	45	45
E	-	11	-	16	-	20
M	M6	M6	M6	M6	M8	M8
Wrench Torque(N · m)	13	13	13	13	30	30
Rated Torque(N · m)	30	30	60	60	120	120
Max Torque(N · m)	60	60	120	120	200	200
Max· RPM(r/min)	7,700	7,700	7,000	7,000	6,000	6,000
Moment of Inertia(Kg · m <sup>2</sup> )	4,0 × 10 <sup>-5</sup>	5,8 × 10 <sup>-5</sup>	1,0 × 10 <sup>-4</sup>	1,4 × 10 <sup>-4</sup>	4,3 × 10 <sup>-4</sup>	5,7 × 10 <sup>-4</sup>
Torsional Stiffness(N · m/rad)	2,0 × 10 <sup>4</sup>	1,0 × 10 <sup>4</sup>	8,0 × 10 <sup>4</sup>	4,0 × 10 <sup>4</sup>	2,6 × 10 <sup>5</sup>	1,3 × 10 <sup>5</sup>
Mass(g)	210	300	380	520	900	1,200
Allowance Angle(°)	0,7	1	0,7	1	0,7	1
Allowance Parallel(± mm)	0	0,3	0	0,3	0	0,3
Allowance End-Play ± (mm)	0,2	0,3	0,2	0,3	0,2	0,3

### 1/10 Taper Bushing

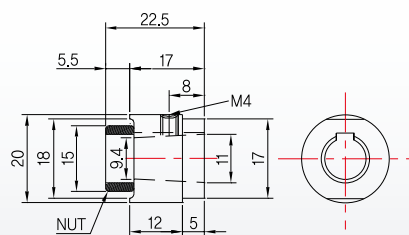
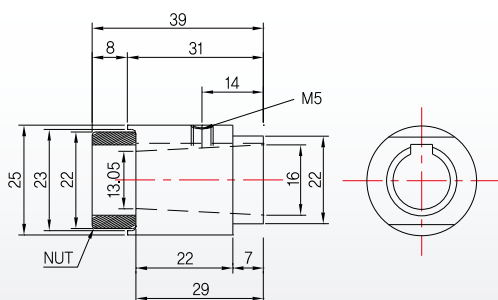

# SHD Series High Torque Flexible Disk Coupling

Please, download CAD DATA on [www.sungilfa.com](http://www.sungilfa.com)

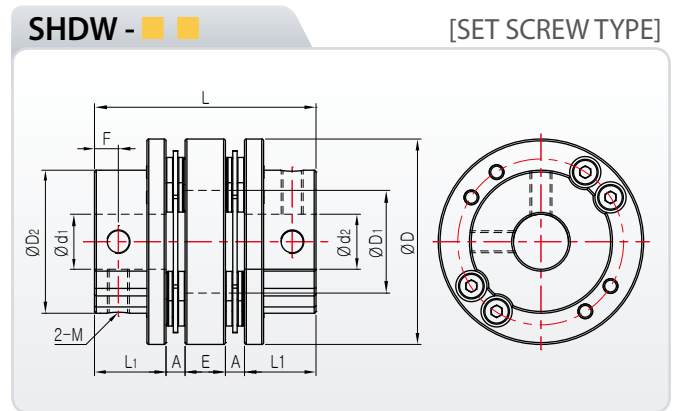
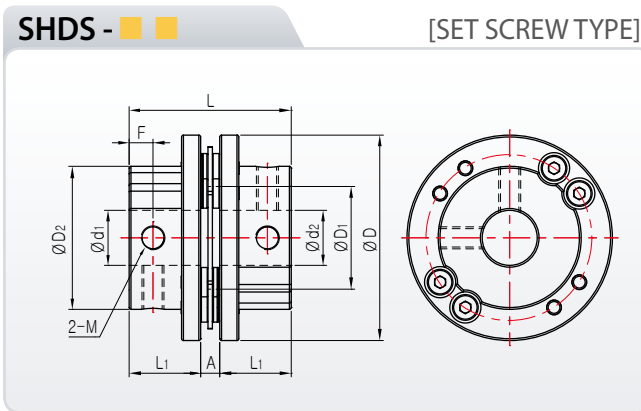

## Standards & Performance

Product Number	SHDS - 56	SHDW - 56	SHDS - 66	SHDW - 66	SHDS - 88	SHDW - 88
Ø D	56	56	66	66	88	88
Ø D <sub>2</sub>	39	39	46	46	63	63
Ø d <sub>1, d<sub>2</sub></sub>	10 ~ 25	10 ~ 25	15 ~ 32	15 ~ 32	20 ~ 45	20 ~ 45
F	6,5	6,5	7,5	7,5	9,5	9,5
L <sub>1</sub>	19,5	19,5	24,5	24,5	30	30
A	5,2	5,2	7,5	7,5	9,6	9,6
L	44,2	60,5	56,5	80	69,5	99,2
Ø D <sub>1</sub>	28	28	33	33	45	45
E	-	11	-	16	-	20
M	M6	M6	M8	M8	M8	M8
Wrench Torque(N · m)	7	7	15	15	15	15
Rated Torque(N · m)	30	30	60	60	120	120
Max Torque(N · m)	60	60	120	120	200	200
Max· RPM(r/min)	8,200	8,200	7,500	7,500	6,500	6,500
Moment of Inertia(Kg · m <sup>2</sup> )	2,9 × 10 <sup>-5</sup>	4,6 × 10 <sup>-5</sup>	8,0 × 10 <sup>-5</sup>	1,2 × 10 <sup>-4</sup>	2,9 × 10 <sup>-4</sup>	4,3 × 10 <sup>-4</sup>
Torsional Stiffness(N · m/rad)	2,0 × 10 <sup>4</sup>	1,0 × 10 <sup>4</sup>	8,0 × 10 <sup>4</sup>	4,0 × 10 <sup>4</sup>	2,6 × 10 <sup>5</sup>	1,3 × 10 <sup>5</sup>
Mass(g)	150	240	300	440	600	900
Allowance Angle(°)	0,7	1	0,7	1	0,7	1
Allowance Parallel(± mm)	0	0,3	0	0,3	0	0,3
Allowance End-Play(± mm)	0,2	0,3	0,2	0,3	0,2	0,3

## Standard Key Groove Size

Diameter (d <sub>1</sub> , d <sub>2</sub> )	b		t		Key Size b × h
	Standard Size	Permissible Level	Standard Size	Permissible Level	
Ø 8Exceed~Ø 10Under	3	±0,0125	1,4	+0,1 0	3 × 3
Ø 10Exceed~Ø 12Under	4	±0,015	1,8		4 × 4
Ø 12Exceed~Ø 17Under	5		2,3		5 × 5
Ø 17Exceed~Ø 22Under	6	±0,018	2,8	+0,2 0	6 × 6
Ø 22Exceed~Ø 30Under	8		3,3		8 × 7
Ø 30Exceed~Ø 38Under	10		3,3		10 × 8

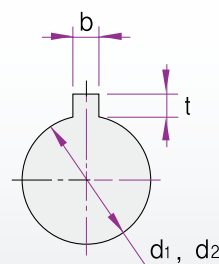

# SHD Series

## High Torque Flexible Disk Coupling

SHDS - ■ ■ T

[TAPER TYPE]

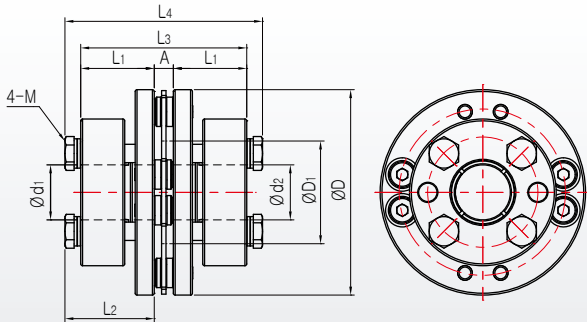

SHDW - ■ ■ T

[TAPER TYPE]

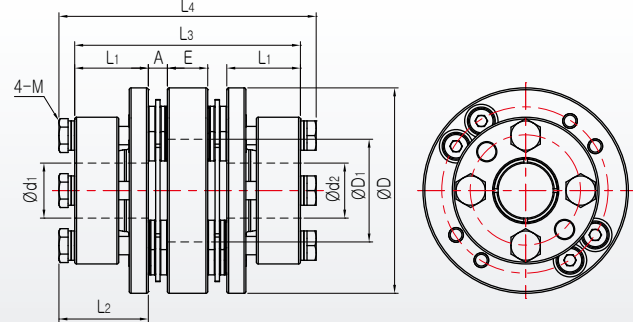

### Standards & Performance

Product Number	SHDS - 56T	SHDW - 56T	SHDS - 66T	SHDW - 66T	SHDS - 88T	SHDW - 88T
ø D	56	56	66	66	88	88
ø d <sub>1</sub> , d <sub>2</sub>	10 ~ 25	10 ~ 25	15 ~ 32	15 ~ 32	20 ~ 45	20 ~ 45
L <sub>1</sub>	20	20	25	25	30	30
L <sub>2</sub>	25	25	30,5	30,5	35,5	35,5
A	5,2	5,2	7,5	7,5	9,6	9,6
L <sub>3</sub>	45,2	61,4	57,5	81	69,5	99,2
L <sub>4</sub>	55	71	68,5	92	80	110
ø D <sub>1</sub>	28	28	33	33	45	45
E	-	11	-	16	-	20
M	M5	M5	M6	M6	M6	M6
Wrench Torque(N · m)	8	8	13	13	13	13
Rated Torque(N · m)	30	30	60	60	120	120
Max Torque(N · m)	60	60	120	120	200	200
Max· RPM(r/min)	7,700	7,700	7,000	7,000	6,000	6,000
Moment of Inertia(Kg · m <sup>2</sup> )	3,6 × 10 <sup>-5</sup>	5,4 × 10 <sup>-5</sup>	8,6 × 10 <sup>-5</sup>	1,2 × 10 <sup>-4</sup>	3,2 × 10 <sup>-4</sup>	4,6 × 10 <sup>-4</sup>
Torsional Stiffness(N · m/rad)	1,4 × 10 <sup>4</sup>	0,7 × 10 <sup>4</sup>	6,5 × 10 <sup>4</sup>	3,3 × 10 <sup>4</sup>	2,0 × 10 <sup>5</sup>	1,0 × 10 <sup>5</sup>
Mass(g)	190	280	320	460	670	970
Allowance Angle(°)	0,7	1	0,7	1	0,7	1
Allowance Parallel(± mm)	0	0,3	0	0,3	0	0,3
Allowance End-Play(± mm)	0,2	0,3	0,2	0,3	0,2	0,3



# SRG Series

## Miniature Rigid Coupling



The compact accurate RIGID COUPLING of SI is one-piece structure. RIGID COUPLING can be used as joint to connect with two shafts. The major characteristic of RIGID COUPLING is that it provides perfect efficiency at any condition that is low and high speed and high torque but that is not flexible. RIGID COUPLING is not accepted amplitude eccentricity and misalignment between one shaft and the other shaft. Therefore please arrange the shaft perfectly for protection of coupling and machinery.

### Features

- Zero backlash
- Maintenance free and excellent resistance against oil and chemicals
- Light weight, extremely low inertia



### Light weight, extremely low inertia

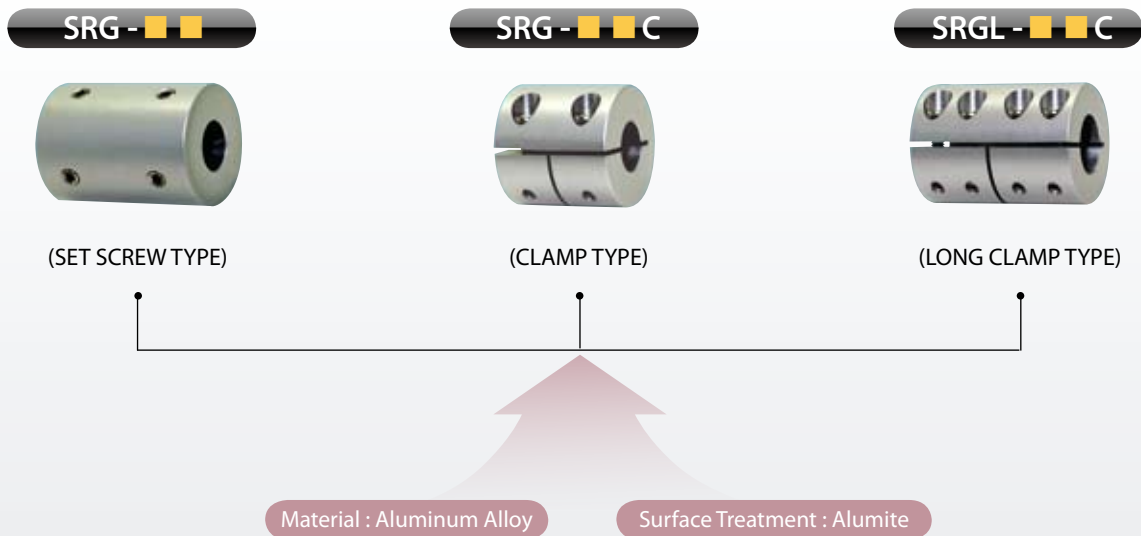

### How to order product

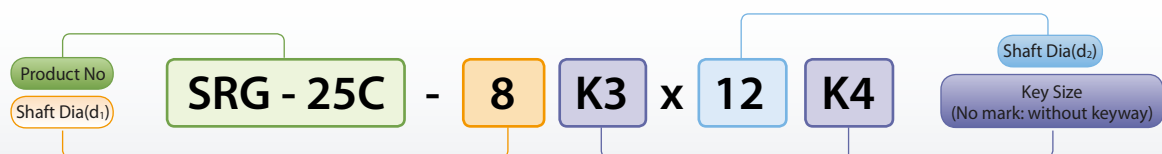

※ Please mark each inner diameter size.

# SRG Series

## Miniature Rigid Coupling

### SRG - ■ ■

[SET SCREW TYPE]

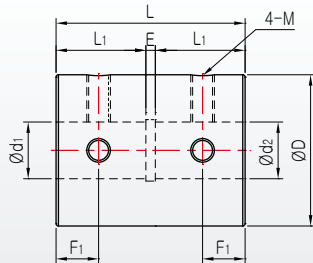

### SRG - ■ ■ C

[CLAMP TYPE]

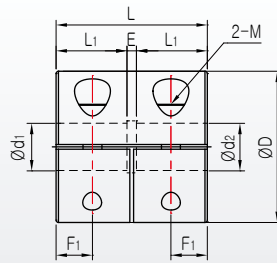

### SRGL - ■ ■ C

[LONG CLAMP TYPE]

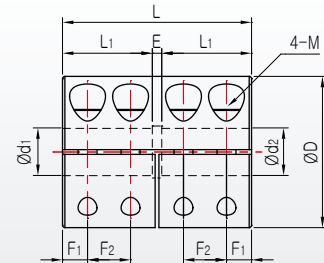

### Standards & Performance

Product Number	Dimension ( $\pm 0,3$ )						Fastening Bolt M	Fastening Torque (N · m)	Max. RPM ( $\text{min}^{-1}$ )	Max Torque (N · m)	Rated Torque (N · m)	Moment of Inertia ( $\text{kg} \cdot \text{m}^2$ )	Mass (g)
	D	L	L <sub>1</sub>	E	F <sub>1</sub>	F <sub>2</sub>							
SRG-16	16	22,5	10,3	2	5	-	M3	0,7	22,000	0,6	0,3	$3,7 \times 10^{-7}$	10
SRG-20	20	24	11	2	5,5	-	M3	0,7	18,000	1	0,5	$1,2 \times 10^{-6}$	20
SRG-25	25	35	16,5	2	7	-	M4	1,7	14,000	2	1	$3,6 \times 10^{-6}$	40
SRG-32	32	40	19	2	9	-	M5	4	12,000	4	2	$1,0 \times 10^{-5}$	71
SRG-43	43	52	25	2	12	-	M6	7	9,000	9	4,5	$4,6 \times 10^{-5}$	170
SRG-53	53	66	32	2	15,5	-	M8	15	6,000	22	11	$1,3 \times 10^{-4}$	360
SRG-16C	16	16	7	2	3,7	-	M2,6	1	9,500	0,6	0,3	$3,0 \times 10^{-7}$	8
SRG-20C	20	20	9	2	4,6	-	M2,6	1	7,000	1	0,5	$8,7 \times 10^{-7}$	15
SRG-25C	25	25	11,5	2	5,8	-	M3	1,7	6,000	2	1	$2,7 \times 10^{-6}$	29
SRG-32C	32	32	15	2	7,6	-	M4	3,5	4,700	4	2	$7,1 \times 10^{-6}$	50
SRG-43C	43	41	19,5	2	10	-	M5	8	4,000	9	4,5	$3,4 \times 10^{-5}$	130
SRG-53C	53	51	24,5	2	12,5	-	M6	13	3,000	22	11	$9,8 \times 10^{-5}$	260
SRGL-16C	16	22,5	10,3	2	3	5,4	M2,6	1	9,000	0,8	0,4	$3,4 \times 10^{-7}$	10
SRGL-20C	20	24	11	2	3,1	5,6	M2,6	1	7,000	1,2	0,6	$9,2 \times 10^{-7}$	18
SRGL-25C	25	35	16,5	2	4,7	7,6	M3	1,7	6,000	2,4	1,2	$3,4 \times 10^{-6}$	38
SRGL-32C	32	40	19	2	5,3	9,1	M4	3,5	4,500	4,8	2,4	$1,0 \times 10^{-5}$	70
SRGL-43C	43	52	25	2	7	11,5	M5	8	3,800	10	5	$4,2 \times 10^{-5}$	160
SRGL-53C	53	66	32	2	9	14,5	M6	13	2,800	24	12	$1,2 \times 10^{-4}$	340

- INNER diameter INCH type is also available
- Non standard inner diameter product is also available

- INNER diameter key type is also available
- Please ask us about inner diameter size before you order.

### Standard Inner diameter

Product Number	Standard Inner diameter ( $d_1, d_2$ ) Standard INNER Diameter (mm)															
	3	4	5	6	8	10	11	12	14	15	16	18	20	22	24	25
SRG-16 / SRG-16C / SRGL-16C	●	●	●	●												
SRG-20 / SRG-20C / SRGL-20C		●	●	●	●	●										
SRG-25 / SRG-25C / SRGL-25C			●	●	●	●	●	●								
SRG-32 / SRG-32C / SRGL-32C				●	●	●	●	●	●	●						
SRG-43 / SRG-43C / SRGL-43C						●	●	●	●	●	●	●	●	●		
SRG-53 / SRG-53C / SRGL-53C								●	●	●	●	●	●	●	●	



# SCJ Series

## Micro Cross Joint Coupling



The precision calibration coupling of the cross joint type, which can easily absorb eccentricity and amplitude instrumentally, is a coupling of unique structure combining both Oldham and universal joint that inhibit resisting force delicately and absorb intake tolerances, and Sungil manufactures the product by simple design in such a way that it increases resonance frequency through high rigidity and low inertia and enhances stoppage extent and responsiveness of precision position deciding instrument.

### Features

- Regular direction and reverse direction are identical and uniform revolution is available
- Has excellent durability and resistance against chemical and oil
- Bearing built in the hub and pin in the center block easily absorb large eccentricity and amplitude
- Pin and bearing are assembled in high level to minimize backlash
- Minimize the generation of resisting force with high torsion rigidity and low inertia
- Deliver control unit angle swiftly in high level
- Various sizes are available

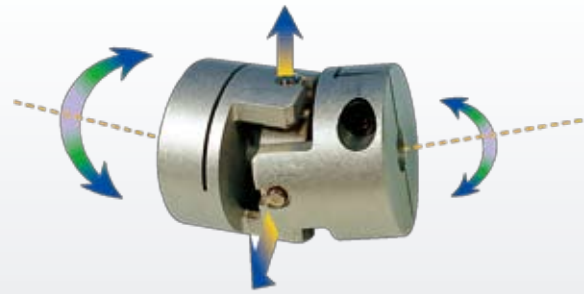

### Structure & Material

Pin : Steel  
Surface Treatment :  
Electroless Nickel Coating

Bush : Dry Bearing

Center Block : Stainless Steel

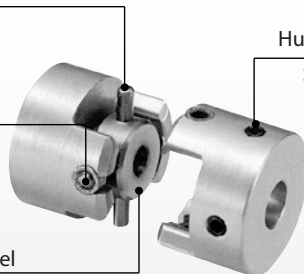

Hub : Aluminum Alloy  
Surface Treatment :  
Alumite



CLAMP TYPE



SET SCREW TYPE

### Application

- Robot, X-Y Table
- Semiconductor related instruments and laser processor
- NC, MC machine tool and precision measuring instrument
- NC woodworking machinery, medical equipment and OA machine
- Optical instrument, measuring instrument and aspheric grinder

### 제품 주문방법

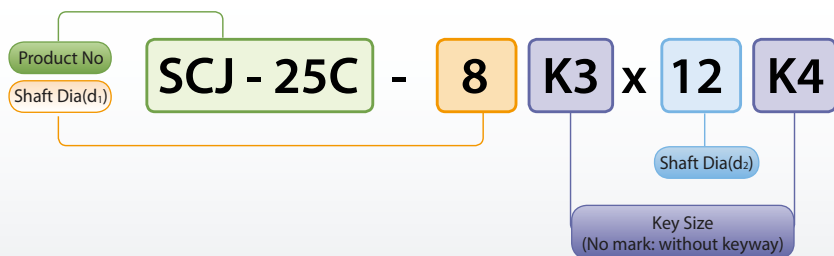

※ Please mark each inner diameter size.

# SCJ Series

## Micro Cross Joint Coupling

SCJ - ■ ■

[SET SCREW TYPE]

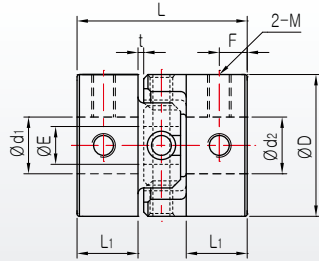

SCJA - ■ ■ C

[CLAMP TYPE]

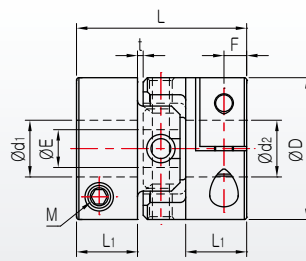

SCJB - ■ ■ C

[CLAMP TYPE]

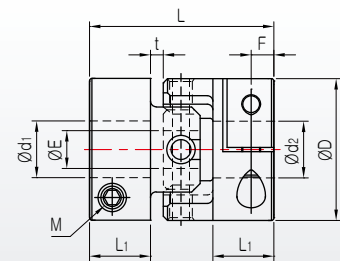

### Performance

Product Number	Fastening Bolt M	Fastening Torque (N · m)	Max · RPM (min <sup>-1</sup> )	Max Torque (N · m)	Rated Torque (N · m)	Torsional Stiffness (N · m/rad)	Moment of Inertia (kg · m <sup>2</sup> )	Mass (g)	Errors of Misalignment		
									Angle (°)	Parallel (mm)	End-Play (mm)
SCJA-15C	M2,6	1	6,000	0,5	0,25	220	3,3 × 10 <sup>-7</sup>	9	3	0,3	0
SCJA-20C	M2,6	1	6,000	1	0,5	350	1,2 × 10 <sup>-6</sup>	19	3	0,5	0
SCJA-25C	M3	1,7	6,000	2	1	800	3,3 × 10 <sup>-6</sup>	34	3	0,5	0
SCJA-32C	M4	3,5	5,000	4	2	1,000	1,1 × 10 <sup>-5</sup>	72	3	0,5	0
SCJA-40C	M5	8	4,000	10	5	1,400	3,2 × 10 <sup>-5</sup>	140	3	0,5	0
SCJB-15C	M2,6	1	6,000	0,5	0,25	200	3,5 × 10 <sup>-7</sup>	10	7	0,3	0
SCJB-20C	M2,6	1	5,000	1	0,5	300	1,3 × 10 <sup>-6</sup>	20	7	0,5	0
SCJB-25C	M3	1,7	5,000	2	1	700	3,4 × 10 <sup>-6</sup>	35	7	0,5	0
SCJB-32C	M4	3,5	4,500	4	2	950	1,2 × 10 <sup>-5</sup>	75	7	0,5	0
SCJB-40C	M5	8	3,500	10	5	1,200	3,3 × 10 <sup>-5</sup>	145	7	0,5	0
SCJ-15	M3	0,7	6,000	0,5	0,25	200	3,3 × 10 <sup>-7</sup>	9	3	0,3	0
SCJ-20	M3	0,7	6,000	1	0,5	450	1,3 × 10 <sup>-6</sup>	20	3	0,5	0
SCJ-25	M4	1,7	6,000	2	1	800	3,4 × 10 <sup>-6</sup>	35	3	0,5	0
SCJ-32	M5	4	5,000	4	2	1,000	1,2 × 10 <sup>-5</sup>	75	3	0,5	0
SCJ-40	M5	4	4,000	10	5	1,300	3,3 × 10 <sup>-5</sup>	145	3	0,5	0

### Standards & Standard Inner diameter

Product Number	Dimension						Standard Inner diameter (d <sub>1</sub> , d <sub>2</sub> ) Standard INNER Diameter (mm)										
	D	L	L <sub>1</sub>	E	t	F	3	4	5	6	6,35	8	10	11	12	14	15
SCJA-15C	15	22,4	8	2,5	0,8	3	●	●	●	●							
SCJA-20C	20	23,6	8	4	0,8	3		●	●	●	●	●					
SCJA-25C	25	30,6	10,5	5	1,3	3,6			●	●	●	●	●				
SCJA-32C	32	39	13,5	8	1,6	4,5				●	●	●	●	●	●	●	
SCJA-40C	40	45,6	16	10	1,9	6						●	●	●	●	●	●
SCJB-15C	15	24,2	8	2,5	1,8	3	●	●	●	●	●						
SCJB-20C	20	26,5	8	4	2,2	3		●	●	●	●	●					
SCJB-25C	25	33,5	10,5	5	2,8	3,6			●	●	●	●	●				
SCJB-32C	32	43	13,5	8	3,6	4,5				●	●	●	●	●	●	●	
SCJB-40C	40	51	16	10	4,5	6						●	●	●	●	●	●
SCJ-15	15	22,4	8	2,5	0,8	3,8	●	●	●	●	●						
SCJ-20	20	23,6	8	4	0,8	3,8		●	●	●	●	●					
SCJ-25	25	30,6	10,5	5	1,3	5			●	●	●	●	●				
SCJ-32	32	39	13,5	8	1,6	6,5				●	●	●	●	●	●	●	
SCJ-40	40	45,6	16	10	1,9	8						●	●	●	●	●	●

■ INNER diameter INCH type is also available

■ Non standard inner diameter product is also available

■ INNER diameter key type is also available

■ We recommend that tolerance of shaft is H7.

# SFC Series

## Micro Flexible Coupling



### Features

- Absorb large amplitude, eccentricity and end play simultaneously
- Absorb shock and vibration perfectly
- No lubrication and low inertia moment

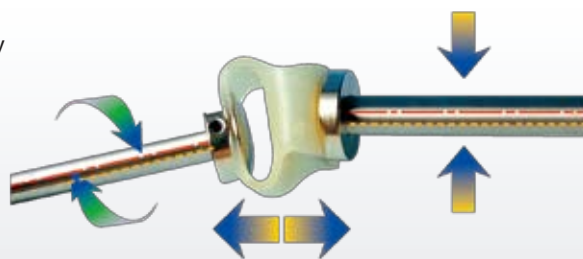

### SFC 29, 38

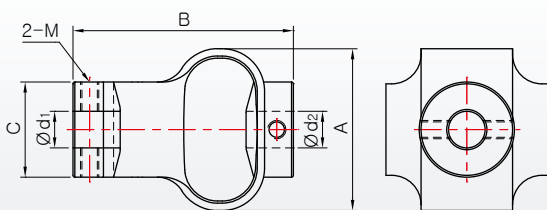

### SFC 48, 54

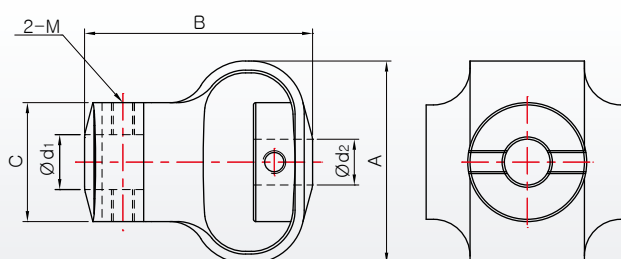

### Standards & Performance

Product Number	Dimension (mm)( $\pm 0,3$ )			Mass (g)	Max. RPM ( $\text{min}^{-1}$ )	Max Torque (N · m)	Angle ( $^{\circ}$ )	Parallel (mm)	End-Play (mm)
	A	B	C						
SFC-29	29	28	18	19	3,000	0,35	10	2	1,5
SFC-38	38	35	22,5	38	3,000	1,35	10	2,5	2
SFC-48	48	50	26	60	3,000	1,8	12	2,5	2
SFC-54	54	58	29,5	140	3,000	4,5	12	3	2

### Standard Inner diameter

Product Number	Standard Inner diameter ( $d_1, d_2$ ) Standard INNER Diameter (mm)								
	4	5	6	8	10	12	14	15	16
SFC-29	•	•	•	•	•				
SFC-38			•	•	•	•			
SFC-48				•	•	•	•		
SFC-54					•	•	•	•	•

※ Please contact us when you order the product without standard inner diameter

### How to order product



※INNER diameter key type is not available about SFC type

※Please mark each inner diameter size.

※Please contact us when you order

# SJC Series

## Zero Backlash Jaw Coupling

JAW COUPLING of SI has such characteristic that cannot be found in other couplings because of its unique construction. It means that the coupling has compound features such as the characteristic of zero backlash metal spring coupling and the characteristic of coupling with common rubber elastic material

### Features

- Zero backlash coupling
- Excellent durability and rigidity against high torsion
- Maintenance and repair are unnecessary and lubrication is not required
- Elastic spider reduces impact of pit load
- Identical regular and reverse rotational characteristics
- Resistance against oil and insulation against electricity
- Operational temperature : -30°C ~ 80°C

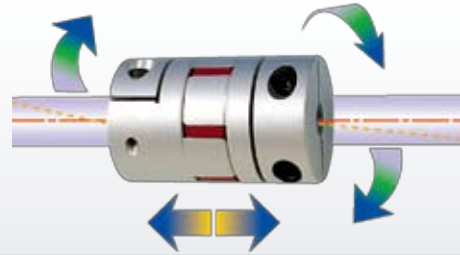

### Sleeve

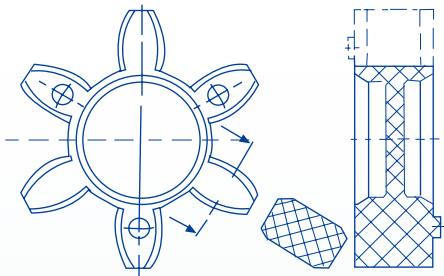

※ SI sleeve is made into non through sleeve that is unique. And teeth of sleeve are made into crown type to easy assembly. The column of sleeve is longer than that of other products, so assembly of this product is not loose.

※ There is the through sleeve that is processed after injection molding in other to easy assembly.

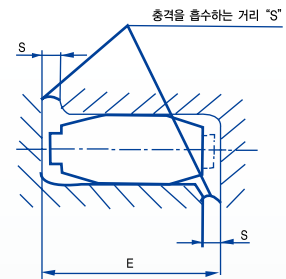

※Elastic isolation by dimension "S" when the coupling is assembled

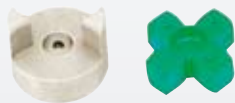

Out Diameter Size  $\varnothing 14 \sim \varnothing 30$



Out Diameter Size  $\varnothing 40$



Out Diameter Size  $\varnothing 55 \sim \varnothing 100$

### Application

- Electric motor
- Position controlling-positioning
- Robot system
- Direct drive of boring and grinding machine
- Machining center (machine tool)
- Medical equipment
- Servo Motor
- X-Y and X-Y-Z axle driving
- Deceleration Motor

### Structure & Material

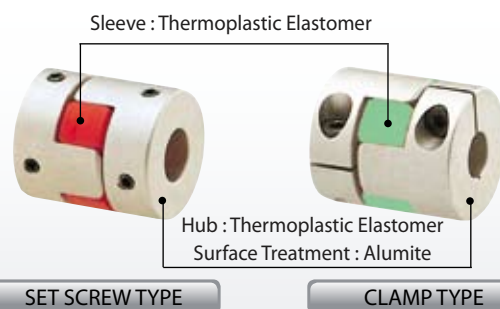

# SJC Series Zero Backlash Jaw Coupling



## Selection Method

Therefore, SJC Series coupling can be divided into 2 purposes of zero backlash method to deliver rotation angle and method to deliver torque mainly. Since each sleeve with different hardness has different characteristic, select appropriate coupling.

### 1. Main purpose is to deliver zero backlash

When using coupling in low torque range in order to deliver rotation angle, same zero backlash characteristic that metal spring coupling offers can be used. In addition, it has the function of absorbing torsion vibration that common coupling cannot offer. When it is used for zero backlash, rotation transfer torque becomes less than the torque listed in the table. Please refer to the table below. Even though torque limit for zero backlash torque is same in 2 sleeves, a sleeve with higher hardness can get higher performance concerning the necessary responsiveness to deliver rotation angle accurately.

### 2. Main purpose to deliver torque

SJC type coupling can be used for higher torque than metal coupling in that it delivers torque by contracting the sleeve. Therefore, it can be applied to general industrial machine such as pump that does not need zero backlash. Even though SJC couplings are standardized in different sleeves, green sleeve with lower hardness has lower usual torque and maximum torque while red sleeve with higher hardness has higher usual torque and maximum torque. On the contrary, misalignment limit is large in green sleeve and smaller in red sleeve. Please, select proper sleeve for use.

Sleeve			Attachment	
Hardness (Shore D)	Color	Material	SET SCREW TYPE	CLAMP TYPE
55D (98A)	Green	Hytral	SJC - ☒☒ - GR	SJC - ☒☒ C - GR
64D	Red	Hytral	SJC - ☒☒ - RD	SJC - ☒☒ C - RD

Product Number	Sleeve Hardness	Zero Backlash (N · m)	Rated Torque (N · m)	Max Torque (N · m)	Twisting Hardness (N · m/rad)	Parallel (mm)	Angle (°)	End-Play (mm)
SJC-14	GR 55D (98A)	0,2	1,2	2,4	14	0,1	1,0	+0,6 0
	RD 64D		2	4	22	0,1		
SJC-20	GR 55D (98A)	0,2	3	6	29	0,15	1,0	+0,8 0
	RD 64D		5	10	55	0,15		
SJC-25	GR 55D (98A)	0,35	5	10	45	0,15	1,0	+1,0 0
	RD 64D		9	18	80	0,1		
SJC-30	GR 55D (98A)	0,5	7,5	15	73	0,15	1,0	+1,0 0
	RD 64D		12,5	25	130	0,1		
SJC-40	GR 55D (98A)	1,2	10	20	570	0,1	1,0	+1,2 0
	RD 64D		17	34	1,200	0,1		
SJC-55	GR 55D (98A)	-	35	70	1,600	0,15	1,0	+1,4 0
	RD 64D		60	120	2,600	0,1		
SJC-65	GR 55D (98A)	-	95	190	3,000	0,15	1,0	+1,5 0
	RD 64D		160	320	4,900	0,1		
SJC-80	GR 55D (98A)	-	190	380	6,500	0,15	1,0	+1,5 0
	RD 64D		320	640	11,000	0,1		
SJC-100	GR 55D (98A)	-	300	600	7,000	0,15	1,0	+2,0 0
	RD 64D		600	1,200	30,000	0,1		

### How to order product

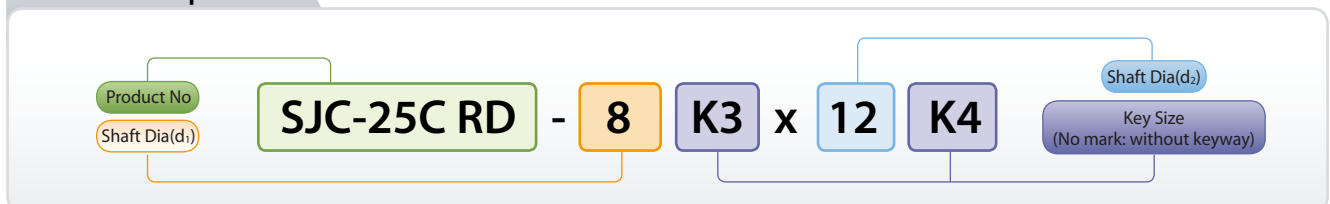

- ※ Please mark each inner diameter size.
- ※ Please mark through type in case of space through type when you order.
- ※ Please refer to following spacer through size.  
SJC-14 =Ø4.5, SJC-20=Ø7, SJC-25=Ø7.6, SJC-30=Ø9.6, SJC-40=Ø15.5, SJC-55=Ø25.3, SJC-65=Ø26.7, SJC-80=Ø30.8, SJC-100=Ø50.5

# SJC Series

## Zero Backlash Jaw Coupling

SJC - -GR(RD)

[SET SCREW TYPE]

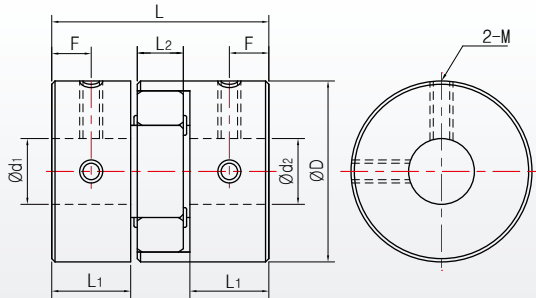

Out Diameter size  $\varnothing 14 \sim \varnothing 30$

SJC - -GR(RD)

[SET SCREW TYPE]

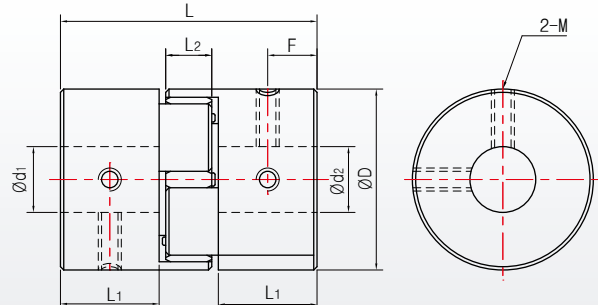

Out Diameter size  $\varnothing 40$

### Standards & Performance

Product Number	Dimension ( $\pm 0,3$ )					Fastening Bolt M	Fastening Torque (N · m)	Max-RPM ( $\text{min}^{-1}$ )	Max Torque (N · m)	Rated Torque (N · m)	Torsional Stiffness (N · m/rad)	Moment of Inertia ( $\text{kg} \cdot \text{m}^2$ )	Mass (g)	Errors of Misalignment		
	D	L	L <sub>1</sub>	L <sub>2</sub>	F									Angle (°)	Parallel (mm)	End-Play (mm)
SJC-14 GR	14	22	7	6	3,5	M3	0,7	27,000	2,4	1,2	14	$2,1 \times 10^{-7}$	7,3	1,0	0,15	$+0,6_0$
SJC-20 GR	20	30	10	8	5	M3	0,7	19,000	6	3	29	$1,0 \times 10^{-6}$	18	1,0	0,15	$+0,8_0$
SJC-25 GR	25	32,5	10	9	5	M4	1,7	15,000	10	5	45	$2,4 \times 10^{-6}$	25	1,0	0,15	$+1,0_0$
SJCA-30 GR	30	35	11,3	10	5,5	M4	1,7	13,000	15	7,5	73	$5,9 \times 10^{-6}$	46	1,0	0,15	$+1,0_0$
SJCB-30 GR	30	44	15,8	10	7,7	M4	1,7	13,000	15	7,5	73	$7,2 \times 10^{-6}$	53	1,0	0,15	$+1,0_0$
SJCA-40 GR	40	55	19,5	12	9	M5	4	9,600	20	10	570	$3,1 \times 10^{-5}$	125	1,0	0,1	$+1,2_0$
SJCB-40 GR	40	66	25	12	11,5	M5	4	9,600	20	10	570	$4,0 \times 10^{-5}$	150	1,0	0,1	$+1,2_0$
SJC-14 RD	14	22	7	6	3,5	M3	0,7	27,000	4	2	22	$2,1 \times 10^{-7}$	7,3	1,0	0,1	$+0,6_0$
SJC-20 RD	20	30	10	8	5	M3	0,7	19,000	10	5	55	$1,0 \times 10^{-6}$	18	1,0	0,1	$+0,8_0$
SJC-25 RD	25	32,5	10	9	5	M4	1,7	15,000	18	9	80	$2,4 \times 10^{-6}$	25	1,0	0,1	$+1,0_0$
SJCA-30 RD	30	35	11,3	10	5,5	M4	1,7	13,000	25	12,5	130	$5,9 \times 10^{-6}$	46	1,0	0,1	$+1,0_0$
SJCB-30 RD	30	44	15,8	10	7,7	M4	1,7	13,000	25	12,5	130	$7,2 \times 10^{-6}$	53	1,0	0,1	$+1,0_0$
SJCA-40 RD	40	55	19,5	12	9	M5	4	9,600	34	17	1200	$3,1 \times 10^{-5}$	125	1,0	0,1	$+1,2_0$
SJCB-40 RD	40	66	25	12	11,5	M5	4	9,600	34	17	1200	$4,0 \times 10^{-5}$	150	1,0	0,1	$+1,2_0$

### Standard Inner diameter

Product Number	Standard Inner diameter (d <sub>1</sub> , d <sub>2</sub> ) Standard INNER Diameter (mm)																	
	3	4	4,5	5	6	6,35	7	8	9,525	10	11	12	14	15	16	18	19	20
SJC-14	●	●	●	●														
SJC-20		●	●	●	●	●	●	●										
SJC-25				●	●	●	●	●	●	●								
SJC-30					●	●	●	●	●	●	●	●						
SJC-40							●	●	●	●	●	●	●	●	●	●		

- INNER diameter INCH type is also available
- INNER diameter key type is also available

- Non standard inner diameter product is also available
- We recommend that tolerance of shaft is H7.

# SJC Series Zero Backlash Jaw Coupling

Please, download CAD DATA on [www.sungilfa.com](http://www.sungilfa.com)

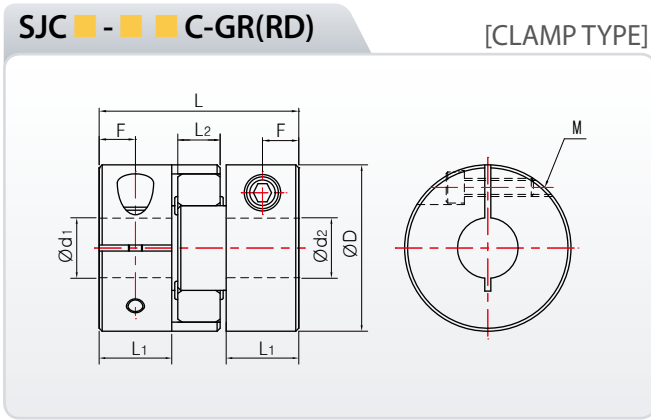

Out Diameter size  $\varnothing 14 \sim \varnothing 30$

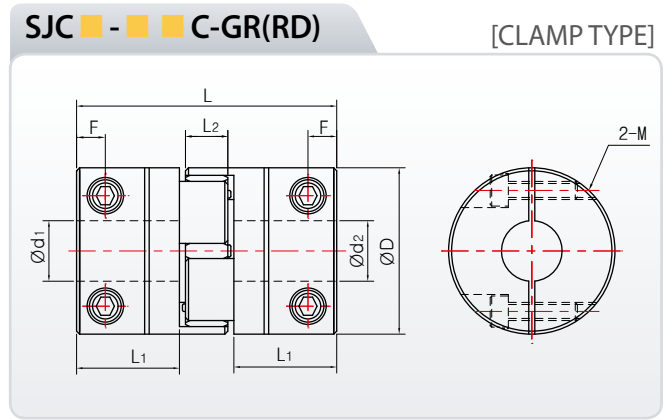

Out Diameter size  $\varnothing 40$

## Standards & Performance

Product Number	Dimension ( $\pm 0,3$ )					Fastening Bolt M	Fastening Torque (N · m)	Max. RPM ( $\text{min}^{-1}$ )	Max Torque (N · m)	Rated Torque (N · m)	Torsional Stiffness (N · m/rad)	Moment of Inertia ( $\text{kg} \cdot \text{m}^2$ )	Mass (g)	Errors of Misalignment		
	D	L	L <sub>1</sub>	L <sub>2</sub>	F									Angle (°)	Parallel (mm)	End-Play (mm)
SJC-14C GR	14	22	7	6	3,5	M2	0,5	11,000	2,4	1,2	14	$1,6 \times 10^{-7}$	6	1,0	0,15	$+0,6_0$
SJC-20C GR	20	30	10	8	5	M2,6	1	7,600	6	3	29	$1,1 \times 10^{-6}$	19	1,0	0,15	$+0,8_0$
SJC-25C GR	25	32,5	10	9	5	M3	1,7	6,200	10	5	45	$2,4 \times 10^{-6}$	25	1,0	0,15	$+1,0_0$
SJCA-30C GR	30	35	11,3	10	5,5	M4	3,5	5,100	15	7,5	73	$6,2 \times 10^{-6}$	50	1,0	0,15	$+1,0_0$
SJCB-30C GR	30	44	15,8	10	5,5	M4	3,5	5,100	15	7,5	73	$7,5 \times 10^{-6}$	55	1,0	0,15	$+1,0_0$
SJCA-40C GR	40	55	19,5	12	6,7	M5	8	3,800	20	10	570	$3,1 \times 10^{-5}$	135	1,0	0,1	$+1,2_0$
SJCB-40C GR	40	66	25	12	8,5	M5	8	3,800	20	10	570	$3,9 \times 10^{-5}$	160	1,0	0,1	$+1,2_0$
SJC-14C RD	14	22	7	6	3,5	M2	0,5	11,000	4	2	22	$1,6 \times 10^{-7}$	6	1,0	0,1	$+0,6_0$
SJC-20C RD	20	30	10	8	5	M2,6	1	7,600	10	5	55	$1,1 \times 10^{-6}$	19	1,0	0,1	$+0,8_0$
SJC-25C RD	25	32,5	10	9	5	M3	1,7	6,200	18	9	80	$2,4 \times 10^{-6}$	25	1,0	0,1	$+1,0_0$
SJCA-30C RD	30	35	11,3	10	5,5	M4	3,5	5,100	25	12,5	130	$6,2 \times 10^{-6}$	50	1,0	0,1	$+1,0_0$
SJCB-30C RD	30	44	15,8	10	5,5	M4	3,5	5,100	25	12,5	130	$7,5 \times 10^{-6}$	55	1,0	0,1	$+1,0_0$
SJCA-40C RD	40	55	19,5	12	6,7	M5	8	3,800	34	17	1,200	$3,1 \times 10^{-5}$	135	1,0	0,1	$+1,2_0$
SJCB-40C RD	40	66	25	12	8,5	M5	8	3,800	34	17	1,200	$3,9 \times 10^{-5}$	160	1,0	0,1	$+1,2_0$

## Standard Inner diameter

Product Number	Standard Inner diameter (d <sub>1</sub> , d <sub>2</sub> ) Standard INNER Diameter (mm)																	
	3	4	4,5	5	6	6,35	7	8	9,525	10	11	12	14	15	16	18	19	20
SJC-14C	●	●	●	●														
SJC-20C		●	●	●	●	●	●	●										
SJC-25C				●	●	●	●	●	●	●								
SJC-30C					●	●	●	●	●	●	●	●	●					
SJC-40C								●	●	●	●	●	●	●	●	●		

- INNER diameter INCH type is also available
- INNER diameter key type is also available

- Non standard inner diameter product is also available
- We recommend that tolerance of shaft is H7.

# SJC Series

## Zero Backlash Jaw Coupling

### SJC - ■ ■ -GR(RD)

[SET SCREW TYPE]

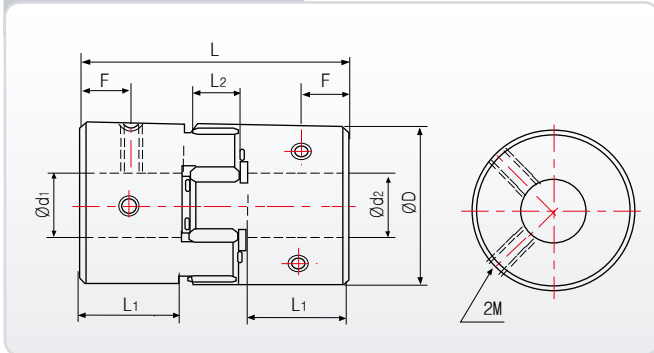

Out Diameter size  $\varnothing 55 \sim \varnothing 100$

### SJC - ■ ■ C-GR(RD)

[CLAMP TYPE]

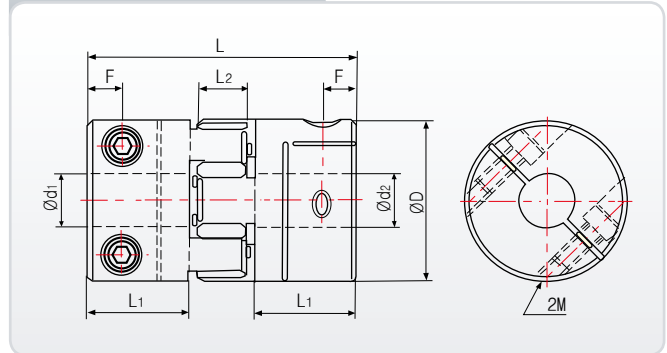

Out Diameter size  $\varnothing 55 \sim \varnothing 100$

### Standards & Performance

Product Number	Dimension ( $\pm 0.3$ )					Fastening Bolt M	Fastening Torque (N·m)	Max·RPM (min <sup>-1</sup> )	Max Torque (N·m)	Rated Torque (N·m)	Torsional Stiffness (N·m/rad)	Moment of Inertia (kg·m <sup>2</sup> )	Mass (g)	Errors of Misalignment		
	D	L	L <sub>1</sub>	L <sub>2</sub>	F									Angle (°)	Parallel (mm)	End-Play (mm)
SJC-55-GR	55	78	30	14	14	M6	7	7,000	70	35	1,600	$1.7 \times 10^{-4}$	350	1	0.15	$+1.4_0$
SJC-65-GR	65	90	35	15	17	M8	15	6,000	190	95	3,000	$3.9 \times 10^{-4}$	570	1	0.15	$+1.5_0$
SJC-80-GR	80	114	45	18	22	M8	15	5,000	380	190	6,500	$1.1 \times 10^{-3}$	1,150	1	0.15	$+1.5_0$
SJC-100-GR	104	140	56	21	27	M10	25	4,000	600	300	7,000	$4.8 \times 10^{-3}$	2,650	1	0.15	$+2.0_0$
SJC-55C-GR	55	78	30	14	10.5	M6	13	3,200	70	35	1,600	$1.6 \times 10^{-4}$	330	1	0.15	$+1.4_0$
SJC-65C-GR	65	90	35	15	13	M8	30	2,700	190	95	3,000	$3.8 \times 10^{-4}$	560	1	0.15	$+1.5_0$
SJC-80C-GR	80	114	45	18	15	M8	30	2,200	380	190	6,500	$1.0 \times 10^{-3}$	1,050	1	0.15	$+1.5_0$
SJC-100C-GR	104	140	56	21	20	M12	90	3,000	600	300	7,000	$4.6 \times 10^{-3}$	2,550	1	0.15	$+2.0_0$
SJC-55-RD	55	78	30	14	14	M6	7	7,000	120	60	2,600	$1.7 \times 10^{-4}$	350	1	0.1	$+1.4_0$
SJC-65-RD	65	90	35	15	17	M8	15	6,000	320	160	4,900	$3.9 \times 10^{-4}$	570	1	0.1	$+1.5_0$
SJC-80-RD	80	114	45	18	22	M8	15	5,000	640	320	11,000	$1.1 \times 10^{-3}$	1,150	1	0.1	$+1.5_0$
SJC-100-RD	104	140	56	21	27	M10	25	4,000	1,200	600	30,000	$4.8 \times 10^{-3}$	2,650	1	0.1	$+2.0_0$
SJC-55C-RD	55	78	30	14	10.5	M6	13	3,200	120	60	2,600	$1.6 \times 10^{-4}$	330	1	0.1	$+1.4_0$
SJC-65C-RD	65	90	35	15	13	M8	30	2,700	320	160	4,900	$3.8 \times 10^{-4}$	560	1	0.1	$+1.5_0$
SJC-80C-RD	80	114	45	18	15	M8	30	2,200	640	320	11,000	$1.0 \times 10^{-3}$	1,050	1	0.1	$+1.5_0$
SJC-100C-RD	104	140	56	21	20	M12	90	3,000	1,200	600	30,000	$4.6 \times 10^{-3}$	2,550	1	0.1	$+2.0_0$

### Standard Inner diameter

Product Number	Standard Inner diameter (d <sub>1</sub> , d <sub>2</sub> ) Standard INNER Diameter (mm)																			
	10	12	14	15	16	18	19	20	22	24	25	26	28	30	32	35	40	45	50	60
SJC-55□		●	●	●	●	●	●	●	●	●	●	●	●							
SJC-65□				●	●	●	●	●	●	●	●	●	●	●	●					
SJC-80□				●	●	●	●	●	●	●	●	●	●	●	●	●	●	●		
SJC-100□								●	●	●	●	●	●	●	●	●	●	●	●	●

- INNER diameter INCH type is also available
- INNER diameter key type is also available

- Non standard inner diameter product is also available
- We recommend that tolerance of shaft is H7.



# SJC Series Zero Backlash Jaw Coupling

Please, download CAD DATA on [www.sungilfa.com](http://www.sungilfa.com)

## SJCM - ■ ■ C-GR(RD)

[CLAMP M TYPE]

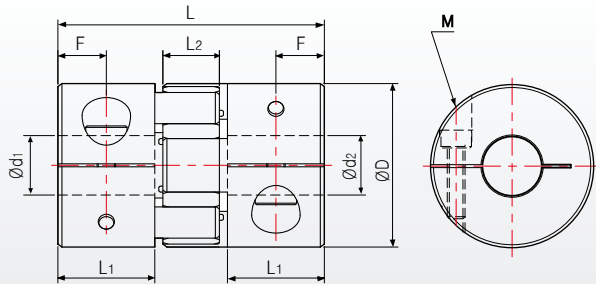

Out Diameter size  $\varnothing 55 \sim \varnothing 100$



[SJCM CLAMP]

### Standards & Performance

Product Number	Dimension ( $\pm 0,3$ )					Fastening Bolt M	Fastening Torque (N · m)	Max. RPM ( $\text{min}^{-1}$ )	Max Torque (N · m)	Rated Torque (N · m)	Torsional Stiffness (N · m/rad)	Moment of Inertia ( $\text{kg} \cdot \text{m}^2$ )	Mass (g)	Errors of Misalignment		
	D	L	L <sub>1</sub>	L <sub>2</sub>	F									Angle (°)	Parallel (mm)	End-Play (mm)
SJCM-55C-GR	55	59	21	14	10,5	M6	13	4,000	70	35	1,600	$1,3 \times 10^{-4}$	280	1	0,15	$+1,4_0$
SJCM-65C-GR	65	63	22	15	11	M8	30	3,500	190	95	3,000	$2,6 \times 10^{-4}$	400	1	0,15	$+1,5_0$
SJCM-80C-GR	80	88	32	18	16	M10	50	3,000	380	190	6,500	$8,7 \times 10^{-4}$	860	1	0,15	$+1,5_0$
SJCM-100C-GR	104	94	34	21	17,5	M12	90	3,000	600	300	7,000	$3,1 \times 10^{-3}$	1,700	1	0,15	$+2,0_0$
SJCM-55C-RD	55	59	21	14	10,5	M6	13	4,000	120	60	2,600	$1,3 \times 10^{-4}$	280	1	0,1	$+1,4_0$
SJCM-65C-RD	65	63	22	15	11	M8	30	3,500	320	160	4,900	$2,6 \times 10^{-4}$	400	1	0,1	$+1,5_0$
SJCM-80C-RD	80	88	32	18	16	M10	50	3,000	640	320	11,000	$8,7 \times 10^{-4}$	860	1	0,1	$+1,5_0$
SJCM-100C-RD	104	94	34	21	17,5	M12	90	3,000	1,200	600	30,000	$3,1 \times 10^{-3}$	1,700	1	0,1	$+2,0_0$

### Standard Inner diameter

Product Number	Standard Inner diameter (d <sub>1</sub> , d <sub>2</sub> ) Standard INNER Diameter (mm)																			
	10	12	14	15	16	18	19	20	22	24	25	26	28	30	32	35	40	45	50	60
SJCM-55C		●	●	●	●	●	●	●	●	●	●	●	●							
SJCM-65C				●	●	●	●	●	●	●	●	●	●	●	●	●				
SJCM-80C				●	●	●	●	●	●	●	●	●	●	●	●	●	●	●		
SJCM-100C								●	●	●	●	●	●	●	●	●	●	●	●	●

- INNER diameter INCH type is also available
- INNER diameter key type is also available

- Non standard inner diameter product is also available
- We recommend that tolerance of shaft is H7.

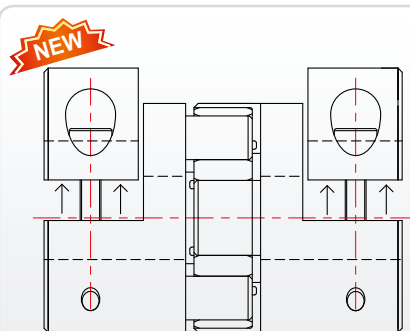

※ It is possible to order the CLAMP Split Type in Out Diameter Size  $\varnothing 30 \sim \varnothing 100$  ( $\varnothing 30$  is only possible B TYPE) but SJCM Type is impossible.

**NEW**



CLAMP SPLIT TYPE



SJC CLAMP

# SJCL Series

## Zero Backlash Long Type Jaw Coupling

### SJC ■ L- ■ ■ C-GR(RD)

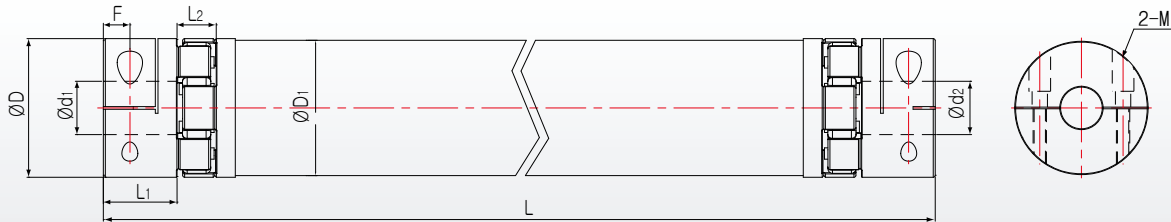

### Features

- Easy attachment and removal
- Easy connection with gear box
- High clamping intensity
- Maximum length : 2,000mm
- It is possible for us to offer clamp split type
- Low moment of inertia by aluminum material



### Standards & Performance

Product Number	Dimension (±0.3)					Fastening Bolt M	Fastening Torque (N·m)	Produce Length (mm)		Max Torque (N·m)	Rated Torque (N·m)	Moment of Inertia (kg·m <sup>2</sup> )		Mass (g)	Errors of Misalignment		
	D	D <sub>1</sub>	L <sub>1</sub>	L <sub>2</sub>	F			Min	Max			Hub	SHAFT		Angle (°)	Parallel (mm)	End-Play (mm)
SJCBL-30C GR	30	29,5	28,8	15,8	5,5	M4	3,5	95	2,000	15	7,5	1,0 X 10 <sup>-5</sup>	3,3 X 10 <sup>-4</sup>	0,47	1	0,15	+1,0 0
SJCBL-40C GR	40	39,5	41	25	8,5	M5	8	130	2,000	20	10	1,3 X 10 <sup>-5</sup>	6,7 X 10 <sup>-4</sup>	1,12	1	0,1	+1,2 0
SJCL-55C GR	55	54	48	30	10,5	M6	13	175	2,000	70	35	4,4 X 10 <sup>-5</sup>	1,2 X 10 <sup>-3</sup>	1,91	1	0,15	+1,4 0
SJCL-65C GR	65	64	55	35	13	M8	30	200	2,000	190	95	1,1 X 10 <sup>-4</sup>	3,0 X 10 <sup>-3</sup>	4,98	1	0,15	+1,5 0
SJCL-80C GR	80	79	69	45	15	M8	30	245	2,000	380	190	2,5 X 10 <sup>-4</sup>	4,5 X 10 <sup>-3</sup>	7,08	1	0,15	+1,5 0
SJCBL-30C RD	30	29,5	28,8	15,8	5,5	M4	3,5	95	2,000	25	12,5	1,0 X 10 <sup>-5</sup>	3,3 X 10 <sup>-4</sup>	0,47	1	0,1	+1,0 0
SJCBL-40C RD	40	39,5	41	25	8,5	M5	8	130	2,000	34	17	1,3 X 10 <sup>-5</sup>	6,7 X 10 <sup>-4</sup>	1,12	1	0,1	+1,2 0
SJCL-55C RD	55	54	48	30	10,5	M6	13	175	2,000	120	60	4,4 X 10 <sup>-5</sup>	1,2 X 10 <sup>-3</sup>	1,91	1	0,1	+1,4 0
SJCL-65C RD	65	64	55	35	13	M8	30	200	2,000	320	160	1,1 X 10 <sup>-4</sup>	3,0 X 10 <sup>-3</sup>	4,98	1	0,1	+1,5 0
SJCL-80C RD	80	79	69	45	15	M8	30	245	2,000	640	320	2,5 X 10 <sup>-4</sup>	4,5 X 10 <sup>-3</sup>	7,08	1	0,1	+1,5 0

### Standard Inner diameter

Product Number	Standard Inner diameter (d <sub>1</sub> , d <sub>2</sub> ) Standard INNER Diameter (mm)																								
	7	8	9,525	10	11	12	14	15	16	18	19	20	22	24	25	26	28	30	32	35	40	45	50	55	60
SJCBL-30C □ □	●	●	●	●	●	●	●																		
SJCBL-40C □ □		●	●	●	●	●	●	●	●	●															
SJCL-55C □ □						●	●	●	●	●	●	●	●	●	●	●	●								
SJCL-65C □ □								●	●	●	●	●	●	●	●	●	●	●	●	●					
SJCL-80C □ □												●	●	●	●	●	●	●	●	●	●	●			

- INNER diameter INCH type is also available
- INNER diameter key type is also available
- Non standard inner diameter product is also available
- We recommend that tolerance of shaft is H7.

### How to order product

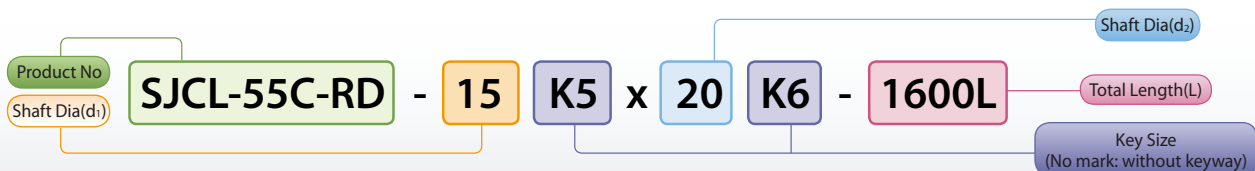

※ Please contact us when you order over max length

※ Please mark each inner diameter size.

※ Please contact us when you order set screw type

# SGF Series

## Sungil Gum Type Flexible Coupling

Sungil Gum Type Coupling (SGF) is realized optimal design and high gain of servo system by high torsion Stiffness and high torque through perfect design of hub and Anti-Vibration Rubber by simulation SGF is perfect product that can yield high torque by spreading stress of torsion

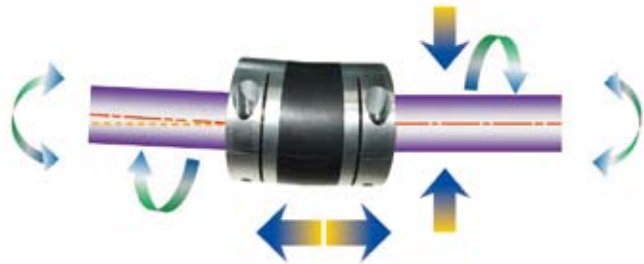

### Features

- Zero Backlash
- No Resonance
- High Vibration Absorption
- High Gain
- Excellent exact position decision
- Identical clockwise and counter-clockwise rotational characteristics
- Available in high speed and torque and torsion stiffness

### Application

- Servo motor
- Stepping motor
- General-purpose motor



### Structure & Material

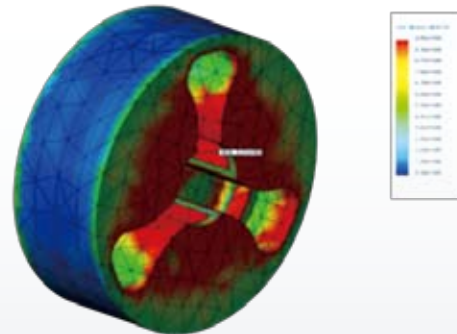

High torsion Stiffness and torque of SGF is realized by optimal design of Anti-Vibration through the newest CAE. And jaw of SGF is designed by round(R) in order to spread stress. So product longevity is significantly increased.

### Physical Chemical Resistant properties of Anti-Vibration (HNBR)

Aging Resistance, Weather Resistance, Ozone Resistance	◎
Gasoline, Light Oil	○~◎
Water, Organic Acid, Alcohol	◎
Strong, Weak Alkali	◎
Acetic Ethyl, Ether	×~△

◎ : Excellence, ○ : Usable,  
△ : Usable under certain conditions, × : Unusable

### How to order product

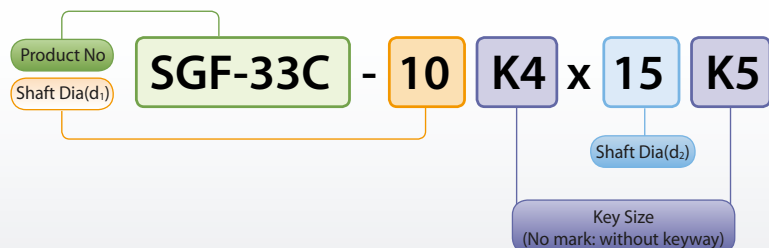

※ Please mark each inner diameter size.

# SGF Series

## Sungil Gum Type Flexible Coupling

SGF- ■ ■ C

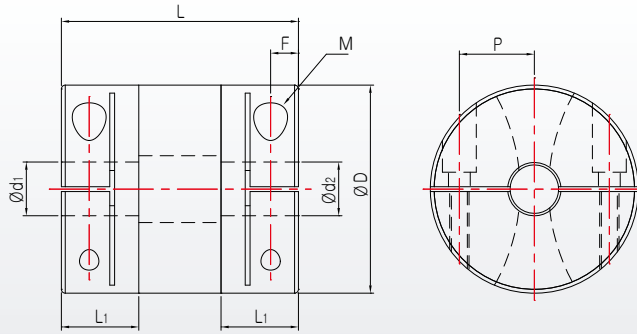

### Standards & Performance

Product Number	Dimension (mm)(±0.3)					Fastening Bolt M	Fastening Torque (N·m)
	D	L	L <sub>1</sub>	F	P		
SGF-14C	14	22	6,5	2,15	4,5	M1,6	0,25
SGF-18C	18	25	7,7	2,7	6,1	M2	0,5
SGF-24C	24	31	9,5	3,3	8,5	M2,6	1
SGF-29C	29	35	11	4	10,5	M3	1,7
SGF-33C	33	37	12	4	11,75	M3	1,7
SGF-38C	38	47	15,5	4,55	14	M4	3,5
SGF-43C	43	47	15	4,75	15,5	M4	3,5
SGF-55C	55	59	95	5,5	18,5	M5	8

Product Number	Max Inner Dia (mm)	Rated Torque (N·m)	Max Torque (N·m)	Max·RPM (min <sup>-1</sup> )	Moment of Inertia (kg·m <sup>2</sup> )	Static Torsional Stiffness (N·m/rad)	Mass (g)	Errors of Misalignment		
								Angle (°)	Parallel (mm)	End-Play (mm)
SGF-14C	6	1,0	2,0	42,000	1,6×10 <sup>-7</sup>	41	8	1,5	0,15	±0,2
SGF-18C	8	1,9	3,8	33,000	3,9×10 <sup>-7</sup>	84	12	1,5	0,15	±0,2
SGF-24C	12	3,5	7	25,000	1,5×10 <sup>-6</sup>	162	28	1,5	0,15	±0,2
SGF-29C	15	5,7	11,4	21,000	3,9×10 <sup>-6</sup>	209	50	1,5	0,20	±0,3
SGF-33C	16	7	14	18,000	7,2×10 <sup>-6</sup>	370	70	1,5	0,20	±0,3
SGF-38C	20	12	24	16,000	1,4×10 <sup>-5</sup>	479	112	1,5	0,20	±0,3
SGF-43C	22	16	32	14,000	2,4×10 <sup>-5</sup>	610	140	1,5	0,20	±0,3
SGF-55C	28	31,5	63	11,000	8,6×10 <sup>-5</sup>	1430	310	1,5	0,20	±0,3

# SGF Series

## Sungil Gum Type Flexible Coupling

Please, download CAD DATA on [www.sungilfa.com](http://www.sungilfa.com)

### Standard Inner diameter

Product Number	Stock Bores							
	Standard Inner diameter (d <sub>1</sub> ,d <sub>2</sub> ) Standard Inner Diameter(mm)							
SGF-14C	3×4	3×5	4×4	4×5	4×6	4,5×5	5×5	5×6
	6×6							
SGF-18C	4×4	4×5	4×6	5×5	5×6	5×7	5×8	6×6
	6×6,35	6×7	6×8	6,35×8	8×8			
SGF-24C	5×5	5×6	5×8	6×6	6×8	6×10	6×11	6×12
	6,35×8	6,35×10	8×8	8×10	8×11	8×12	10×10	10×12
	12×12							
SGF-29C	6×6	6×8	6×10	8×8	8×10	8×11	8×12	8×14
	8×15	10×10	10×11	10×12	10×14	10×15	11×12	12×12
	12×14	12×15	14×14	14×15	15×15			
SGF-33C	8×8	8×10	8×11	8×12	8×14	8×15	10×10	10×11
	10×12	10×14	10×15	11×11	11 X 12	12×12	12×14	12×15
	14×14	14×15	15×15	16×16				
SGF-38C	8×8	8×10	8×12	10×10	10×12	10×14	10×15	10×16
	12×12	12×14	12×15	12×16	12×19	12×20	14×14	14×15
	14×16	15×15	15×16	15×19	16×16	17×17	20×20	
SGF-43C	10×10	10×12	10×14	12×12	12×14	12×15	12×16	12×19
	14×14	14×15	14×16	14×19	15×15	15×16	15×19	15×20
	16×16	16×19	17×17	19×20	20×20			
SGF-55C	12×12	12×14	14×14	14×15	14×16	15×15	15×19	15×20
	15×25	19×20	19×24	20×20	20×25	24×25	25×25	

- Six angle Wench Bolt is included in SGF
- We recommend that tolerance of shaft is H7
- No standard and Keyway is possible, please ask us before order.
- Please contact us when you order product excepted standard inner diameter size.

### Adjustment of Torque according to Temperature

Ambient temperature	-20℃ ~ 30℃	30℃ ~ 40℃	40℃ ~ 60℃	60℃ ~ 80℃
Correction value	1	0,8	0,7	0,55

Maximum torque and rated torque should be not checked by load fluctuation.

When ambient temperature exceeds 30℃, maximum torque and rated torque should be checked by the correction value chart above.

Operational temperature is from -20℃ to 80℃.

## *Support Units*



## *FA Units*



# Sungil Support Units

Support Units

Sungil Support Units

Joint Unit

Bearing Unit

Set Collars

Lock Nut

Power Lock Series

EK, EF Type Support Units



BK, BF Type Support Units



AK, AF Type Support Units



FK, FF Type Support Units



# Characteristics of SI Support Units

The Support Units SI Machinery are precisely standardized in order to accurately maintain, firmly fix and support the rotational movement of ball screw or sliding screw that is used for power transmission of linear motion.

## Features

### Simplicity of Design and Assembly

Standardization of product allows highly effective design. Additional assembly process is not required, and the stability of assembly precision can be easily improved as bearing of the support unit is assembled at optimal preload condition. Moreover, the standardized product ensures superior compatibility.

### High Precision

Angular contact ball bearing is precisely assembled in face-to-face duplex format. The influence by assembly error is minimized and the precision of rotation shaft is maintained as the product structure is designed to absorb parallel error between rotational shaft and guide about the center of the shaft.

### Dust-Proof Effect

The support unit is framed with oil seal to prevent the influx of fine dusts or foreign substances and thus enhances operation precision. Furthermore, it allows longtime use as grease leakage is prevented by minimizing the tolerance between the oil seal and the rotation shaft.

## Structure

The support unit for fixture part is assembled by angular ball bearing with high rigidity and low torque in face-to-face duplex format that is appropriate to the dynamic property of rotation shaft. In addition, it can achieve highly accurate rotation capability through precise adjustment on preload. The support unit for support part uses deep groove ball bearing. There is oil seal framed in the unit, and it prevents the grease from leaking. It prevents the influx of fine dusts or foreign substances and allows longtime use.

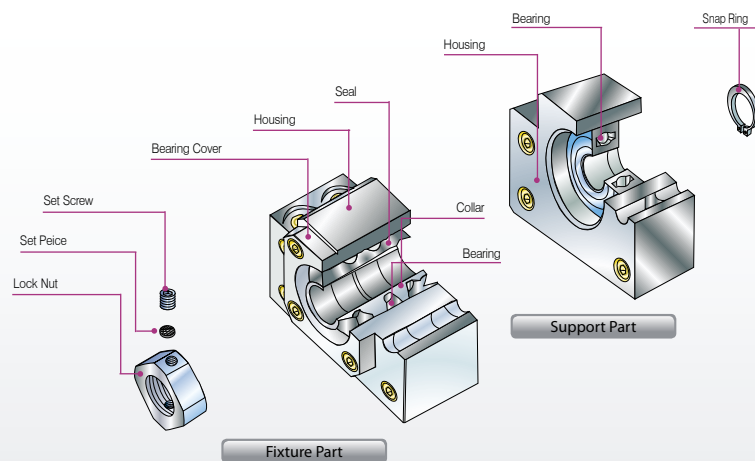

## Shape and Classification

There are two types of units that are available for different conditions of installation and use. One employs angle type (block type) structure where the unit is fixed on the base surface, and the other employs round type (flange type) structure where the unit is inserted into a hole for fixation. The unit is also divided into two parts depending on the position of power transmission shaft—the part for fixture (motor) on one side and the part for support on the other side.

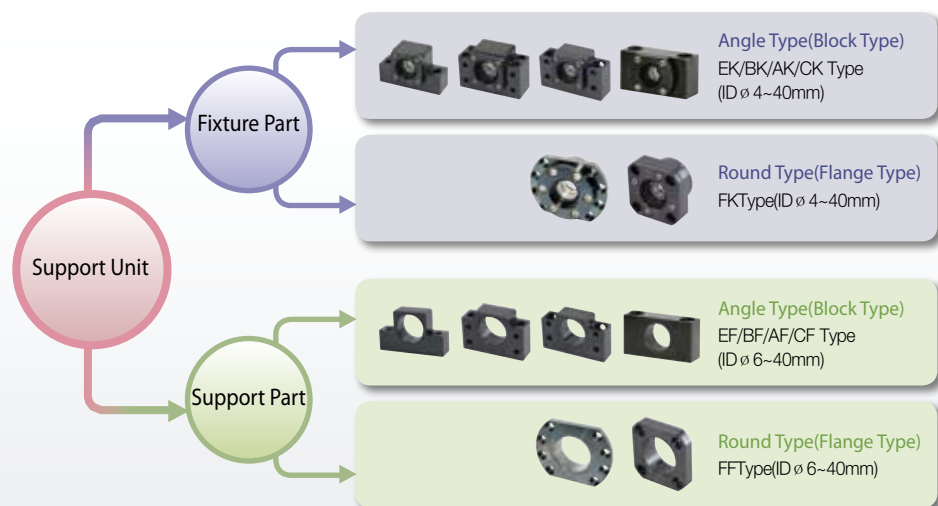



# Characteristics of SI Support Units

Please, download CAD DATA on [www.sungilfa.com](http://www.sungilfa.com)

## Steps to install the Support Unit

### 1. Assemble to Support Units

- 1) Connect the unit for fixture part to ball screw
  - It is not allowed to disassemble the unit as its preload has been already controlled
  - The wing part of the oil seal should not be folded when ball screw is inserted into the unit.
- 2) After inserting the ball screw into the unit, put the collar and couple and adjust the locknut. Then place the set piece in the stop screw part of the locknut and tighten the stop screw (see page 60)
  - Adhesive can be used to prevent the locknut from being loosened.
- 3) Mount the nut bracket on ball screw.
- 4) After connecting the unit ball bearing for support part to the ball screw, fix the snap ring and assemble to the housing.

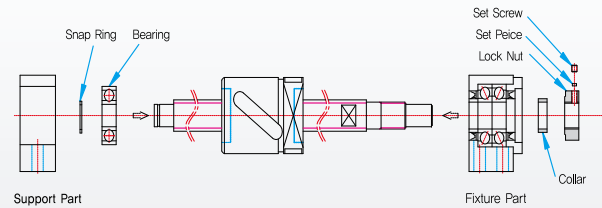

### 2. Assemble to Table and Base

- 1) Connect table to the nut bracket of ball screw.
- 2) Preassemble the support unit for fixture part to the designed position of the base.
  - When the unit for fixture part is the standard, adjust to have clearance in external diameter of the nut and internal diameter of the table or bracket.
  - When the table is the standard, adjust the height of angle type unit. For flange type, adjust to have clearance in external diameter and internal diameter.
- 3) Connect the unit housing for support part to ball screw and preassemble to the designed position of the base.

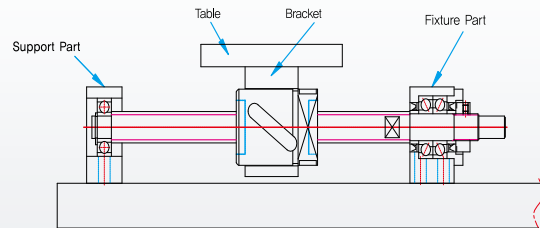

### 3. Precision of Rotation Shaft and Coupling

- 1) Move the table connected to the ball screw toward the center of the shaft in order to place the center of the shaft properly. Make alternating motion so that its linear movement can become smooth.
- 2) While measuring the tolerance toward the direction of the shaft and the vibration at the end of the rotational shaft of the ball screw, measure the center of the shaft and couple in the order of nut bracket and table, the unit for fixture part, the unit for support part and base.

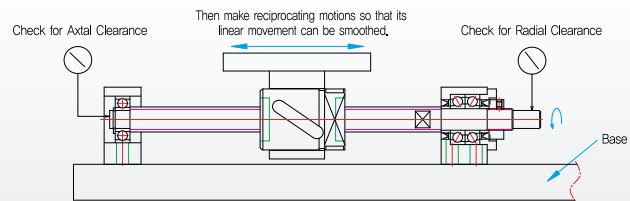

### 4. Drive Motor and Assembly

- 1) Precisely connect the bracket installed on the motor to the base by matching it with the shaft center of the ball screw.
- 2) Connect the coupling to the motor and the shaft for fixture part.
  - Careful attention is necessary during assembly as the assembly condition of the motor bracket and the coupling affects the positioning of table.
- 3) Check the precision of the shaft center by conducting enough test operation while driving the motor at slow speed.

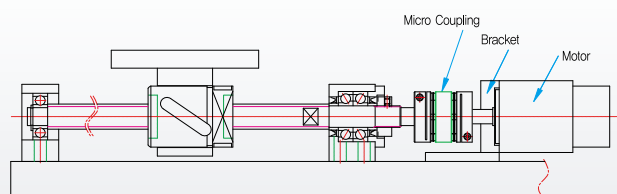

# Characteristics of SI Support Units

## Recommendable Shape for Ball Screw

### Application of Support Unit EK, BK, AK, FK Type

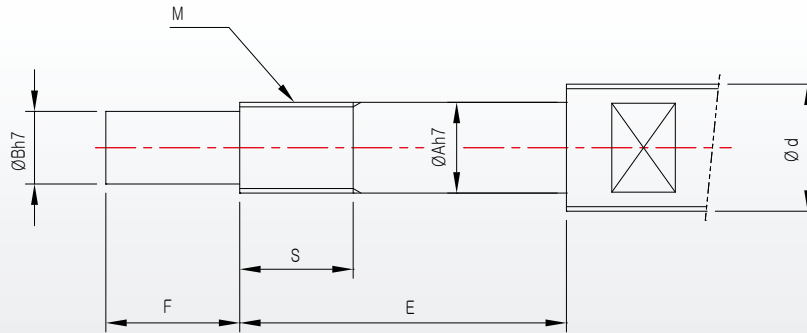

Unit : mm

Model No.			OD of Ball Screw	ID of Bearing	Dimension			Meter Screw	
FK Type	EK Type	AK Type	d	A	B	E	F	M	S
FK4	EK4		6	4	3	23	5	M4×0,5	8
FK5	EK5		8	5	4	25	6	M5×0,5	8
FK6	EK6		8	6	4	30	8	M6×0,75	8
FK8	EK8(AK8)		12	8	6	35(30)	9	M8×1/0,75	10
FK10	EK10		14/15	10	8	36	15	M10×1/0,75	11
FK12	EK12		16/18	12	10	36	15	M12×1	11
FK15	EK15		20/25	15	12	49	20	M15×1	13
FK17	-		25	17	15	53	27	M17×1	14
FK20	EK20		28/30/32	20	17	59	25	M20×1	17
FK25	EK25		36	25	20	76	30	M25×1,5	20
FK30	-		40	30	25	72	38	M30×1,5	25
FK35	-		45	35	30	83	45	M35×1,5	28
FK40	-		50/55	40	35	98	50	M40×1,5	35
BK6	-		8	6	4	30	8	M6×0,75	8
BK8	-		12	8	6	35	9	M8×1/0,75	10
BK10	AK10		14/15	10	8	39	15	M10×1	16
BK12	AK12		16/18	12	10	39	15	M12×1	14
BK15	AK15		20	15	12	40	20	M15×1	12
BK17	-		25	17	15	53	23	M17×1	17
BK20	AK20		28/30/32	20	17	53	25	M20×1	16
BK25	-		36	25	20	65	30	M25×1,5	19
BK30	-		40	30	25	72	38	M30×1,5	25
BK35	-		45	35	30	83	45	M35×1,5	28
BK40	-		50/55	40	35	98	50	M40×1,5	35

# Characteristics of SI Support Units

Please, download CAD DATA on [www.sungilfa.com](http://www.sungilfa.com)

## Recommendable Shape for Ball Screw

### Application of Support Unit EF, BF, AF, FF Type

FF Type

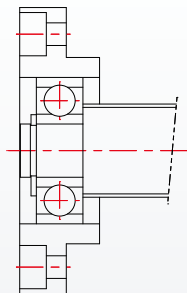

AF Type / EF Type / BF Type

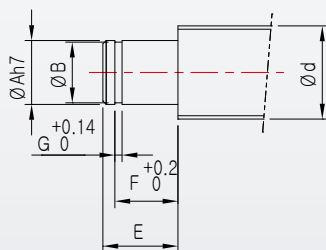
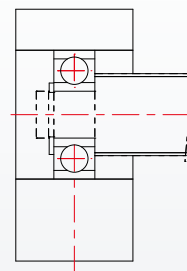
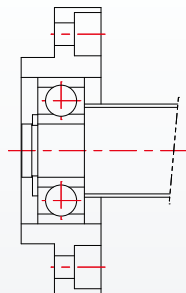

Unit : mm

Model No.				OD of Ball Screw	ID of Bearing		Snap Ring Dimension		
AF Type	FF Type	EF Type	BF Type	d	A	E	B	F	G
-	FF6	EF6	BF6	8	6	9	5,6	6,9	0,9
AF8	FF8	EF8	BF8	12	6	9	5,6	6,9	0,9
AF10	FF10	EF10	BF10	14	8	10	7,6	7,9	0,9
AF10	FF10	EF10	BF10	15	8	10	7,6	7,9	0,9
AF12	FF12	EF12	BF12	16	10	11	9,6	9,15	1,15
AF12	FF12	EF12	BF12	18	10	11	9,6	9,15	1,15
AF15	FF15	EF15	BF15	20	15	13	14,3	10,15	1,15
AF15	FF15	EF15	BF15	25	15	13	14,3	10,15	1,15
-	FF17	-	BF17	25	17	16	16,2	13,15	1,15
AF20	FF20	EF20	BF20	28	20	19(16)	19	15,35(13,35)	1,35
-	FF20	EF20	BF20	30	20	19(16)	19	15,35(13,35)	1,35
-	FF20	EF20	BF20	32	20	19(16)	19	15,35(13,35)	1,35
-	FF25	-	BF25	36	25	20	23,9	16,35	1,35
-	FF30	-	BF30	40	30	21	28,6	17,75	1,75
-	-	-	BF35	45	35	22	33	18,75	1,75
-	-	-	BF40	50	40	23	38	19,95	1,95
-	-	-	BF40	55	40	23	38	19,95	1,95

※( )marks BF 20's dimension

# EK Type Support Unit

## Angle Type for Fixture



### EK 6~8

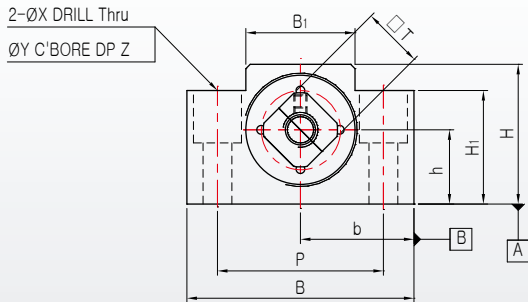

### EK 4, 5

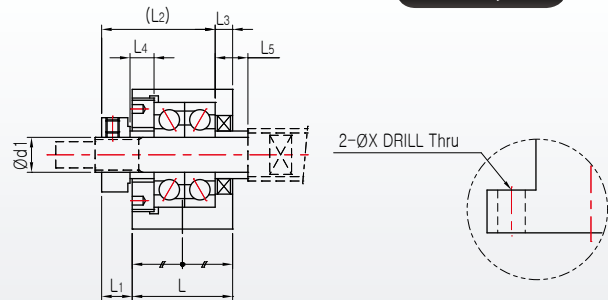

### EK 10~20

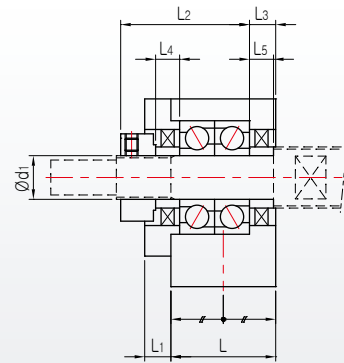
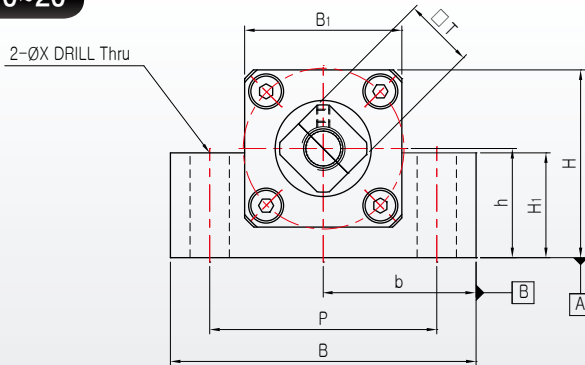

### Note

1. Installation can be conducted based on the surface of A and B. Please, use the spacer of accurate size when adjustment of height or length is necessary.
2. It is not allowed to disassemble the support unit as the preload of the bearing has been already controlled.
3. Precise amount of grease is filled in the support unit.
4. EK-4~EK-5 general type is used radial ball bearing and in small axial load.
5. Please refer to page 55 about bearing type and characteristic according to Support Unit grade
6. Please refer to page 60 about attachment torque of the lock nut.

### EK 25 Reference

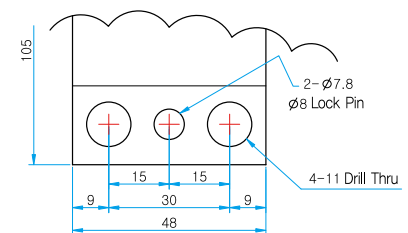

Unit : mm

Model No.	d <sub>1</sub>	L	L <sub>1</sub>	L <sub>2</sub>	L <sub>3</sub>	B	H	b±0.02	h±0.02	B <sub>1</sub>	H <sub>1</sub>	P	X	Y	Z	Collar Size		□ T	Mass(g)
																L <sub>4</sub>	L <sub>5</sub>		
EK4	4	15	5.5	18.5	2	34	19	17	10	18	7	26	4.5	-	-	3.5	3.5	10	50
EK5	5	16.5	6.5	19.5	3.5	36	21	18	11	20	8	28	4.5	-	-	4.5	4.5	11	68
EK6	6	20	5.5	22	3.5	42	25	21	13	18	20	30	5.5	9.5	11	5	7	12	120
EK8	8	23	7	26	4	52	32	26	17	25	26	38	6.6	11	12	5.5	7.5	14	230
EK10	10	24	6	29.5	6	70	43	35	25	36	24	52	9	-	-	5.5	5.5	16	430
EK12	12	24	6	29.5	6	70	43	35	25	36	24	52	9	-	-	5.5	5.5	19	420
EK15	15	25	6	36	5	80	50	40	30	41	25	60	11	-	-	10	10	22	530
EK20	20	42	10	50	10	95	58	47.5	30	56	25	75	11	-	-	11	11	30	1310
EK25	25	48	13	59	14	105	68	52.5	35	66	25	85	(Refer to Drawing)			14	14	35	1950

# EF Type Support Unit

## Angle Type for Support

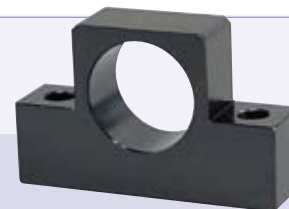

Please, download CAD DATA on [www.sungilfa.com](http://www.sungilfa.com)

### EF 6 ~ 8

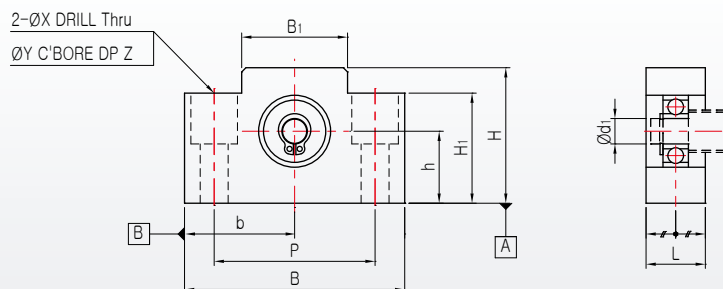

### EF 10 ~ 25

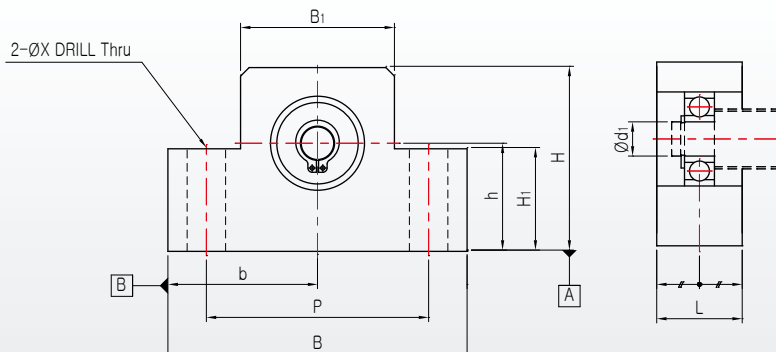

### Note

1. Installation can be conducted based on the surface of A and B. Please, use the spacer of accurate size when adjustment of height or length is necessary.



Unit : mm

Model No.	d <sub>1</sub>	L	B	H	b±0,02	h±0,02	B <sub>1</sub>	H <sub>1</sub>	P	X	Y	Z	Mess(g)	Bearing	Snap Ring
EF6	6	12	42	25	21	13	18	20	30	5,5	9,5	11	60	606ZZ	C6
EF8	6	14	52	32	26	17	25	26	38	6,6	11	12	120	606ZZ	C6
EF10	8	20	70	43	35	25	36	24	52	9	-	-	300	608ZZ	C8
EF12	10	20	70	43	35	25	36	24	52	9	-	-	280	6000ZZ	C10
EF15	15	20	80	50	40	30	41	25	60	9	-	-	320	6002ZZ	C15
EF20	20	26	95	58	47,5	30	56	25	75	11	-	-	570	6204ZZ	C20
EF25	25	30	105	68	52,5	35	66	25	85	11	-	-	880	6205ZZ	C25

# BK Type Support Unit

## Angle Type for Fixture



### BK 6 ~ 8

2- $\varnothing$ X DRILL Thru  
 $\varnothing$ Y C'BORE DP Z

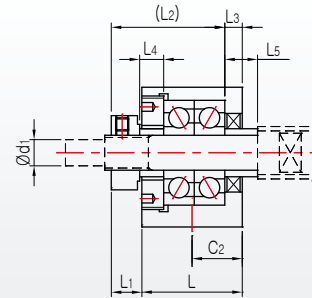
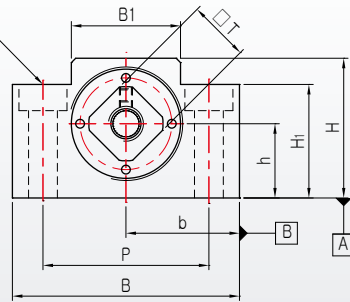

### BK10~ 40

4- $\varnothing$ X DRILL Thru  
 $\varnothing$ Y C'BORE DP Z  
 4- $\varnothing$ d2 DRILL Thru

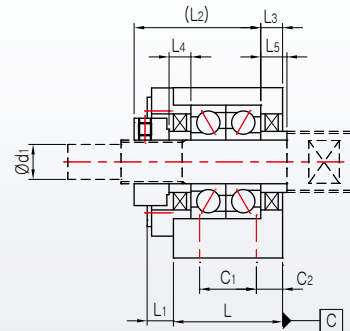
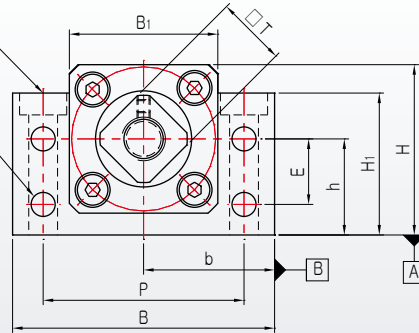

### Note

1. Installation can be conducted based on the surface of A and B. Please, use the spacer of accurate size when adjustment of height or length is necessary.
2. It is not allowed to disassemble the support unit as the preload of the bearing has been already controlled.
3. Precise amount of grease is filled in the support unit.
4. Tighten the setscrew after connecting the locknut to ball screw and performing adjustment.
5. Please refer to page 55 about bearing type and characteristic according to Support Unit grade
6. Please refer to page 60 about attachment torque of the lock nut.

Unit : mm

Model No.	d <sub>1</sub>	L	L <sub>1</sub>	L <sub>2</sub>	L <sub>3</sub>	B	H	b±0,02	h±0,02	B <sub>1</sub>	H <sub>1</sub>	E	P	C <sub>1</sub>	C <sub>2</sub>	d <sub>2</sub>	X	Y	Z	Collar Size		□T	Mess(g)
																				L <sub>4</sub>	L <sub>5</sub>		
BK6	6	23	5	24	4	52	32	26	17	25	26	-	38	-	11,5	-	6,6	11	6	5	5	12	230
BK8	8	23	7	26	4	52	32	26	17	25	26	-	38	-	11,5	-	6,6	11	6	5,5	7,5	14	230
BK10	10	25	5	29	5	60	39	30	22	34	32,5	15	46	13	6	5,5	6,6	10,8	5	5	5	16	360
BK12	12	25	5	29	5	60	43	30	25	34	35	18	46	13	6	5,5	6,6	10,8	6	5	5	19	390
BK15	15	27	6	32	6	70	48	35	28	40	38	18	54	15	6	5,5	6,6	10,8	6	6	6	22	530
BK17	17	35	9	44	7	86	64	43	39	50	55	28	68	19	8	6,6	9	14	8,5	7	7	24	1270
BK20	20	35	8	43	8	88	60	44	34	52	50	22	70	19	8	6,6	9	14	8,5	8	8	30	1650
BK25	25	42	12	54	9	106	80	53	48	64	70	33	85	22	10	9	11	17,5	11	9	9	35	2310
BK30	30	45	14	61	9	128	89	64	51	76	78	33	102	23	11	11	14	20	13	9	9	40	3330
BK35	35	50	14	67	12	140	96	70	52	88	79	35	114	26	12	11	14	20	13	12	12	50	4380
BK40	40	61	18	76	15	160	110	80	60	100	90	37	130	33	14	14	18	26	17,5	15	15	50	6670

# BF Type Support Unit

## Angle Type for Support

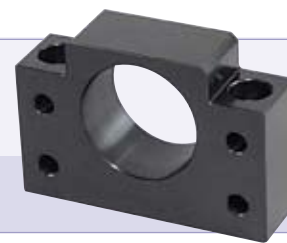

Please, download CAD DATA on [www.sungilfa.com](http://www.sungilfa.com)

### BF6~8

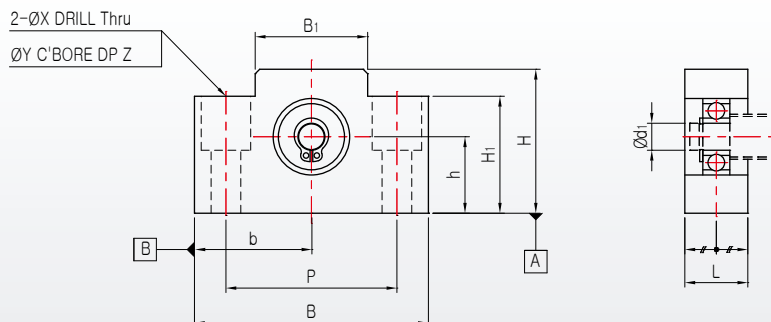

### BF10~40

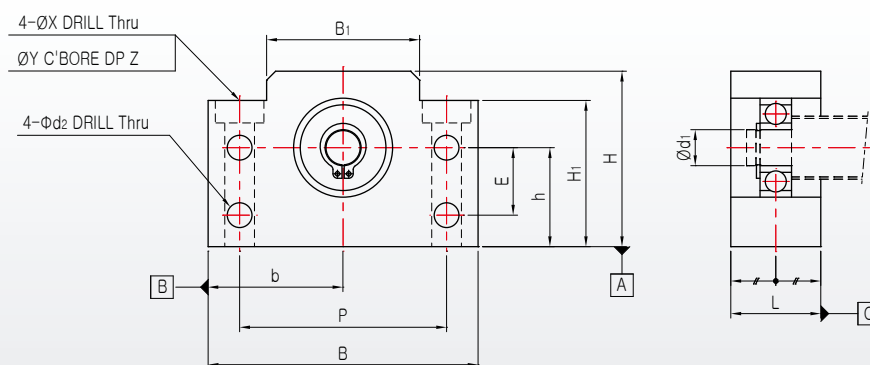

### Note

1. Installation can be conducted based on the surface of A and B. Please, use the spacer of accurate size when adjustment of height or length is necessary.



Unit : mm

Model No.	d <sub>1</sub>	L	B	H	b±0.02	h±0.02	B <sub>1</sub>	H <sub>1</sub>	E	P	d <sub>2</sub>	X	Y	Z	Mess(g)	Bearing	Snap Ring
BF6/8	6	14	52	32	26	17	25	26	-	38	-	6,6	11	12	120	606ZZ	C6
BF10	8	20	60	39	30	22	34	32,5	15	46	5,5	6,6	10,8	5	260	608ZZ	C8
BF12	10	20	60	43	30	25	34	35	18	46	5,5	6,6	10,8	6,5	270	6000ZZ	C10
BF15	15	20	70	48	35	28	40	38	18	54	5,5	6,6	10,8	6,5	310	6002ZZ	C15
BF17	17	23	86	64	43	39	50	55	28	68	6,6	9	14	8,5	680	6203ZZ	C17
BF20	20	26	88	60	44	34	52	50	22	70	6,6	9	14	8,5	710	6004ZZ	C20
BF25	25	30	106	80	53	48	64	70	33	85	9	11	17,5	11	1340	6205ZZ	C25
BF30	30	32	128	89	64	51	76	78	33	102	11	14	20	13	1880	6206ZZ	C30
BF35	35	32	140	96	70	52	88	79	35	114	11	14	20	13	2080	6207ZZ	C35
BF40	40	37	160	110	80	60	100	90	37	130	14	18	26	17,5	3100	6208ZZ	C40

# AK Type Support Unit

## Angle Type for Fixture



AK 8 ~ 20

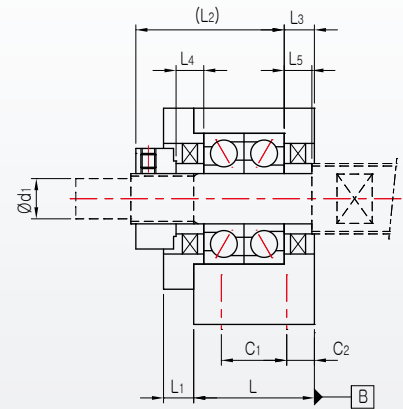
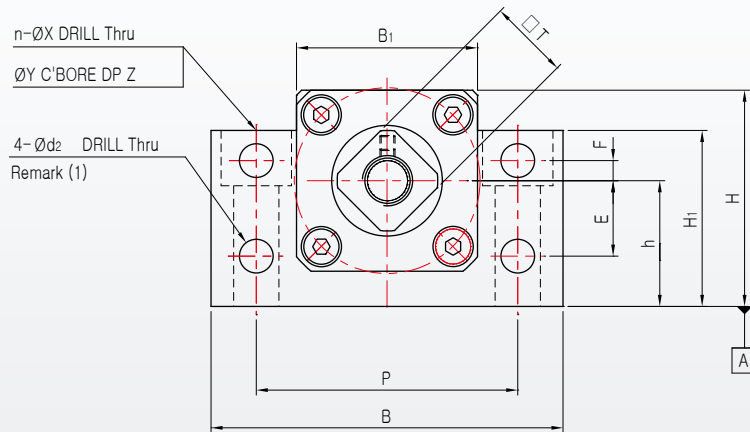

Remark (1) : AK20 is no Hole

### Note

1. Installation can be conducted based on the surface of A and B. Please, use the spacer of accurate size when adjustment of height or length is necessary.
2. It is not allowed to disassemble the support unit as the preload of the bearing has been already controlled.
3. Precise amount of grease is filled in the support unit.
4. Tighten the setscrew after connecting the locknut to ball screw and performing adjustment.
5. Please refer to page 55 about bearing type and characteristic according to Support Unit grade
6. Please refer to page 60 about attachment torque of the lock nut.

Unit : mm

Model No.	d <sub>1</sub>	L	L <sub>1</sub>	L <sub>2</sub>	L <sub>3</sub>	B	H	h±0.02	B <sub>1</sub>	H <sub>1</sub>	E	F	P	C <sub>1</sub>	C <sub>2</sub>	d <sub>2</sub>	n	X	Y	Z	Collar Size		□T	Mess(g)
																					L <sub>4</sub>	L <sub>5</sub>		
AK8	8	20	3	24	4	52	32	17	25	26	10	4	38	-	10	5.5	2	6.6	11	12	4	4	14	190
AK10	10	24	6	29.5	6	70	43	25	36	35	15	4	52	-	12	6.6	2	9	14	11	5.5	5.5	16	450
AK12	12	24	6	29.5	6	70	43	25	36	35	15	4	52	-	12	6.6	2	9	14	11	5.5	5.5	19	440
AK15	15	25	6	36	5	80	50	30	41	40	15	4	60	-	12.5	6.6	2	11	17	15	10	10	22	570
AK20	20	42	10	50	10	95	58	30	56	45	-	-	75	22	10	-	4	11	17	15	11	11	30	1400



# AF Type Support Unit

## Angle Type for Support



Please, download CAD DATA on [www.sungilfa.com](http://www.sungilfa.com)

AF 8 ~ 20

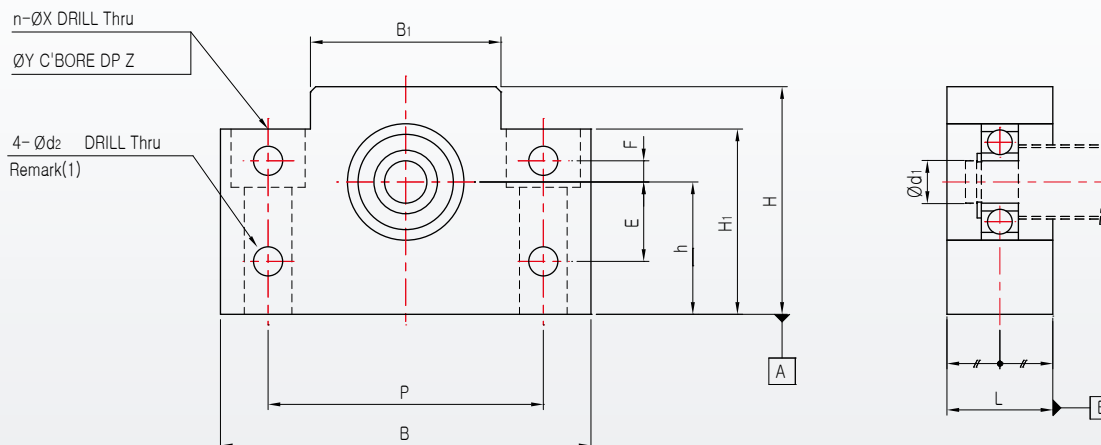

Remark (1) : AF20 is no Hole

### Note

1. Installation can be conducted based on the surface of A and B. Please, use the spacer of accurate size when adjustment of height or length is necessary.



Unit : mm

Model No.	d <sub>1</sub>	L	B	H	h±0.02	B <sub>1</sub>	H <sub>i</sub>	E	F	P	d <sub>2</sub>	X	Y	Z	Mess(g)	Bearing	Snap Ring
AF8	6	15	52	32	17	25	26	10	4	38	5.5	6.6	11	12	130	606ZZ	C6
AF10	8	20	70	43	25	36	35	15	4	52	6.6	9	14	11	320	608ZZ	C8
AF12	10	20	70	43	25	36	35	15	4	52	6.6	9	14	11	300	6000ZZ	C10
AF15	15	20	80	50	30	41	40	15	4	60	6.6	9	14	11	370	6002ZZ	C15
AF20	20	26	95	58	30	56	45	-	-	75	-	11	17	15	660	6204ZZ	C20

# FK Type Support Unit

## Round Type for Fixture

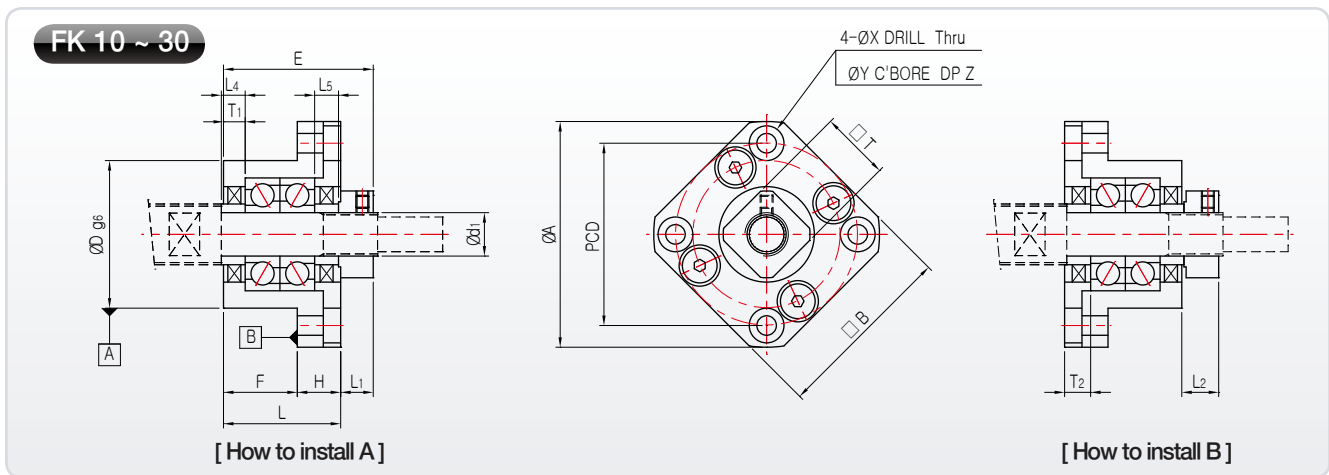
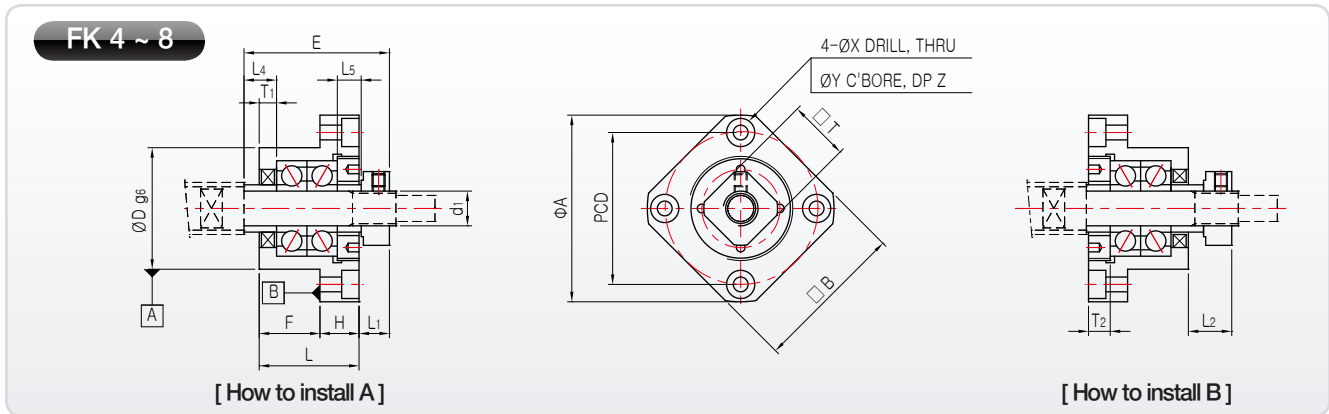
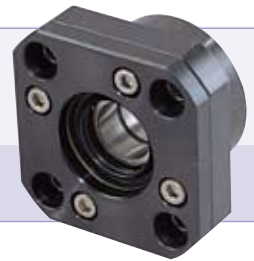

### Note

1. Installation can be conducted based on the surface of A and B. Please, use the spacer of accurate size when adjustment of height or length is necessary.
2. It is not allowed to disassemble the support unit as the preload of the bearing has been already controlled.
3. Precise amount of grease is filled in the support unit.
4. Tighten the setscrew after connecting the locknut to ball screw and performing adjustment.
5. Please refer to page 55 about bearing type and characteristic according to Support Unit grade
6. Please refer to page 60 about attachment torque of the lock nut.

Unit : mm

Model No.	d <sub>1</sub>	L	H	F	E	D	A	PCD	□ B	How to install A		How to install B		X	Y	Z	Collar Size		□ T	Mess(g)
										L <sub>1</sub>	T <sub>1</sub>	L <sub>2</sub>	T <sub>2</sub>				L <sub>4</sub>	L <sub>5</sub>		
FK4	4	15	6	9	22	18	32	24	25	5,5	2	6,5	3	3,4	6	4	3,5	3,5	10	40
FK5	5	16,5	6	10,5	24	20	34	26	26	6,5	3,5	6	3	3,4	6,5	4	4,5	4,5	11	50
FK6	6	20	7	13	29	22	36	28	28	5,5	3,5	8,5	4,5	3,4	6,5	4	7	5	12	65
FK8	8	23	9	14	33,5	28	43	35	35	7	4	10	5	3,4	6,5	4	7,5	5,5	14	125
FK10	10	27	10	17	29,5	34	52	42	42	7,5	5	8,5	6	4,5	8	4	5,5	5,5	16	200
FK12	12	27	10	17	29,5	36	54	44	44	7,5	5	8,5	6	4,5	8	4	5,5	5,5	19	225
FK15	15	32	15	17	36	40	63	50	52	10	6	12	8	5,5	9,5	6	10	10	22	340
FK17	17	45	22	23	46	50	77	62	61	10	9	13	12	6,6	11	10	9	9	24	770
FK20	20	52	22	30	50	57	85	70	68	8	10	12	14	6,6	11	10	11	11	30	1065
FK25	25	57	27	30	60	63	98	80	79	13	10	20	17	9	15	13	15	15	35	1465
FK30	30	62	30	32	61	75	117	95	93	11	12	17	18	11	17,5	15	9	9	40	2300

# FF Type Support Unit

## Round Type for Support

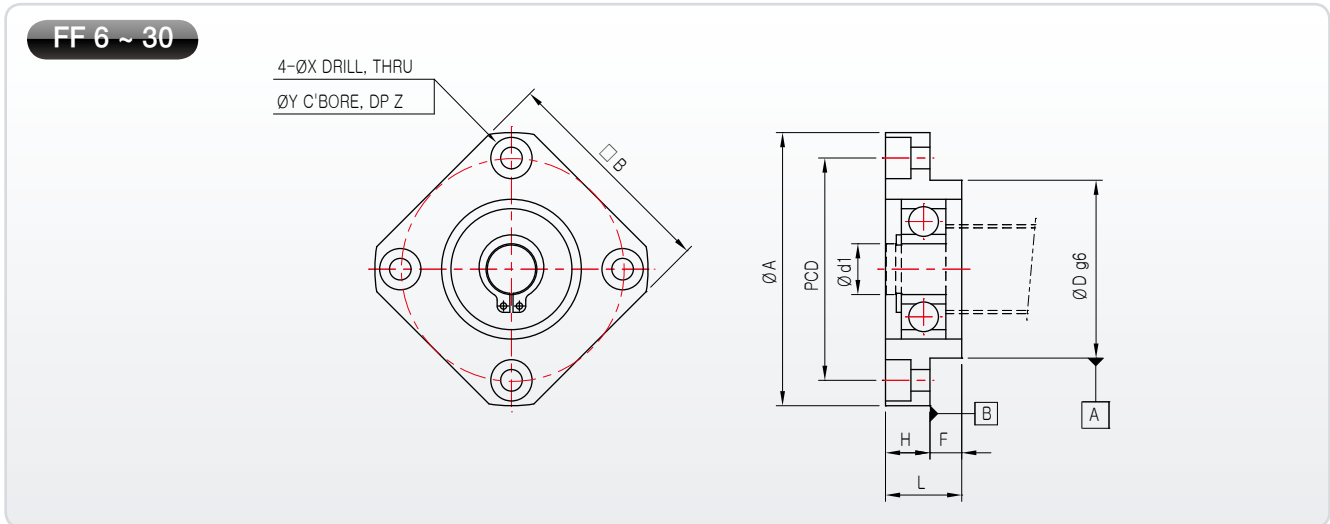
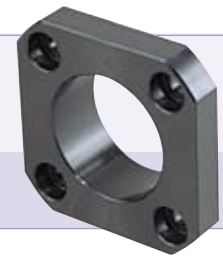

### Note

1. Installation can be conducted based on the surface of A and B. Please, use the spacer of accurate size when adjustment of height or length is necessary.



Unit : mm

Model No.	d <sub>i</sub>	L	H	F	D	A	PCD	B	X	Y	Z	Mess(g)	Bearing	Snap Ring
FF6-8	6	10	6	4	22	36	28	28	3,4	6,5	3	30	606ZZ	C6
FF10	8	12	7	5	28	43	35	35	3,4	6,5	4	60	608ZZ	C8
FF12	10	15	7	8	34	52	42	42	4,5	8	4	100	6000ZZ	C10
FF15	15	17	9	8	40	63	50	52	5,5	9,5	5,5	140	6002ZZ	C15
FF17	17	20	11	9	50	77	62	61	6,5	11	6,5	290	6203ZZ	C17
FF20	20	20	11	9	57	85	70	68	6,6	11	6,5	380	6204ZZ	C20
FF25	25	24	14	10	63	98	80	79	9	14	8,5	590	6205ZZ	C25
FF30	30	27	18	9	75	117	95	93	11	17,5	11	930	6206ZZ	C30

# FK/FF Type Support Unit

## Round Type for Fixture



Please, download CAD DATA on [www.sungilfa.com](http://www.sungilfa.com)

### FK 35 ~ 40

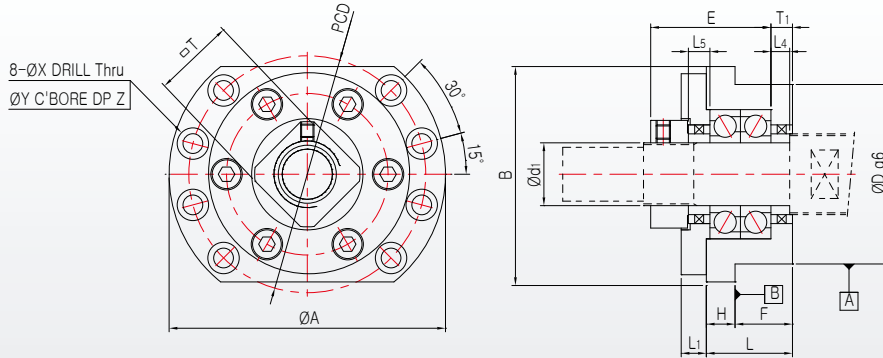

### FF 35 ~ 40

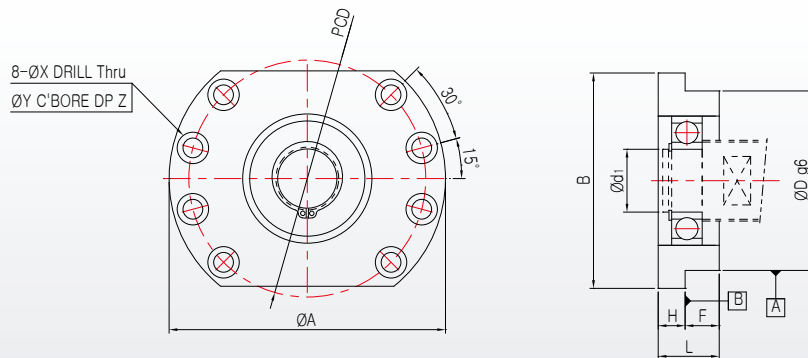

### Note

1. Installation can be conducted based on the surface of A and B. Please, use the spacer of accurate size when adjustment of height or length is necessary.
2. It is not allowed to disassemble the support unit as the preload of the bearing has been already controlled.
3. Precise amount of grease is filled in the support unit.
4. Tighten the setscrew after connecting the locknut to ball screw and performing adjustment.
5. Please refer to page 55 about bearing type and characteristic according to Support Unit grade
6. Please refer to page 60 about attachment torque of the lock nut.

Unit : mm

Model No.	d <sub>1</sub>	L	H	F	E	D	A	PCD	B	L <sub>1</sub>	T <sub>1</sub>	X	Y	Z	Collar Size		□ T	Mess(g)
															L <sub>4</sub>	L <sub>5</sub>		
FK35	35	48	16	32	67	100	154	132	120	14	12	11	17,5	11	12	12	50	4080
FK40	40	61	18	43	76	120	176	150	128	18	16	14	20	13	15	15	50	6750

Unit : mm

Model No.	d <sub>1</sub>	L	H	F	D	A	PCD	B	X	Y	Z	Bearing	Snap Ring	Mess(g)
FF35	35	34	15	19	100	154	132	120	11	17,5	11	6207ZZ	C35	2050
FF40	40	36	18	18	120	176	150	128	14	20	13	6208ZZ	C40	3050

# CK/CF Type Support Unit



Low Center Type for Fixture / Low Center Type for Support

Please, download CAD DATA on [www.sungilfa.com](http://www.sungilfa.com)

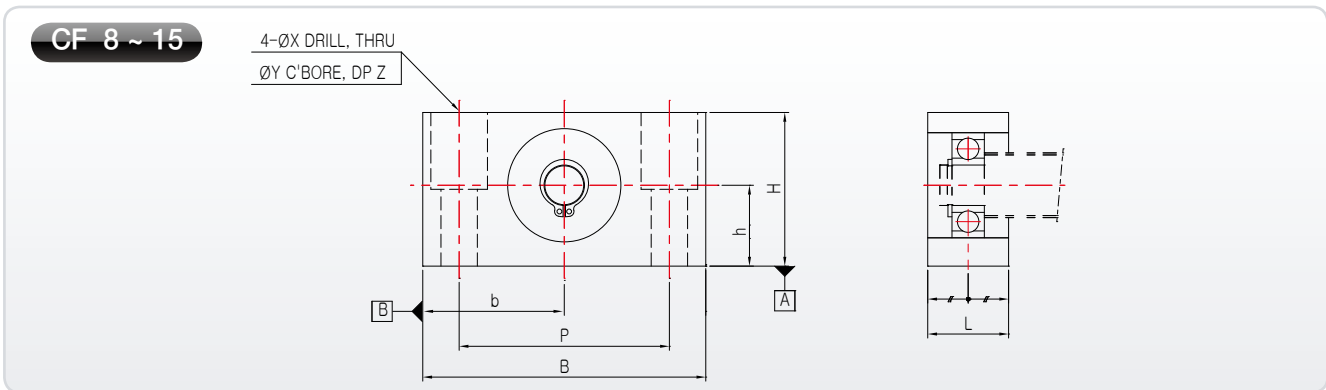
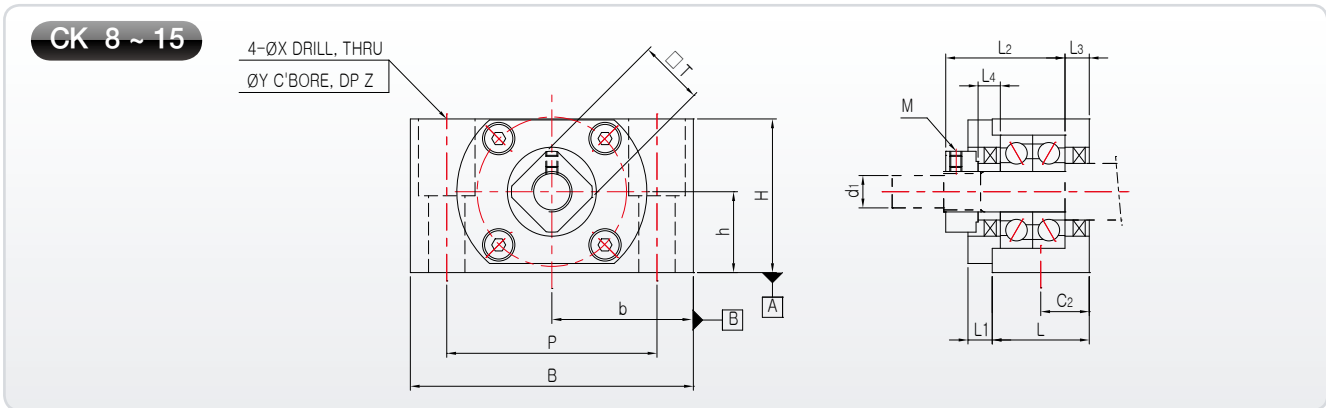

## Note

1. Installation can be conducted based on the surface of A and B. Please, use the spacer of accurate size when adjustment of height or length is necessary.
2. It is not allowed to disassemble the support unit as the preload of the bearing has been already controlled.
3. Precise amount of grease is filled in the support unit.
4. Tighten the setscrew after connecting the locknut to ball screw and performing adjustment.
5. Please refer to page 55 about bearing type and characteristic according to Support Unit grade
6. Please refer to page 60 about attachment torque of the lock nut.

Unit : mm

Model No.	d <sub>1</sub>	L	L <sub>1</sub>	L <sub>2</sub>	L <sub>3</sub>	B	H	b±0,02	h±0,02	P	C <sub>2</sub>	X	Y	Z	Collar Size	M	□T	Mess(g)
															L <sub>4</sub>			
CK8	8	21,5	4	26,5	3,5	62	31	31	15,5	46	11	9	14	18	6	M3x0,5	14	260
CK10	10	24	6	29,5	6	70	38	35	20	52	12	9	14	19	5,5	M4x0,7	16	430
CK12	12	24	6	29,5	6	70	38	35	20	52	12	9	14	19	5,5	M4x0,7	19	430
CK15	15	25	6	38	5	80	42	40	22	60	12,5	11	17	23	10	M4x0,7	22	540

Unit : mm

Model No.	d <sub>1</sub>	L	B	H	b±0,02	h±0,02	P	X	Y	Z	Bearing	Snap Ring	Mess(g)
CF8	6	16	62	31	31	15,5	46	9	14	18	606ZZ	C6	165
★ CF12	10	20	70	38	35	20	52	9	14	19	6000ZZ	C10	285
CF15	15	20	80	42	40	22	60	9	14	23	6002ZZ	C15	355

★CF12 is used to the CK10, CK12 into the common support unit.

# WBK type Support Unit

## Miniature Type

Please, download CAD DATA on [www.sungilfa.com](http://www.sungilfa.com)

### WBK TYPE Miniature Support Unit

• Support unit can be applied when precision miniature ball screw is used.

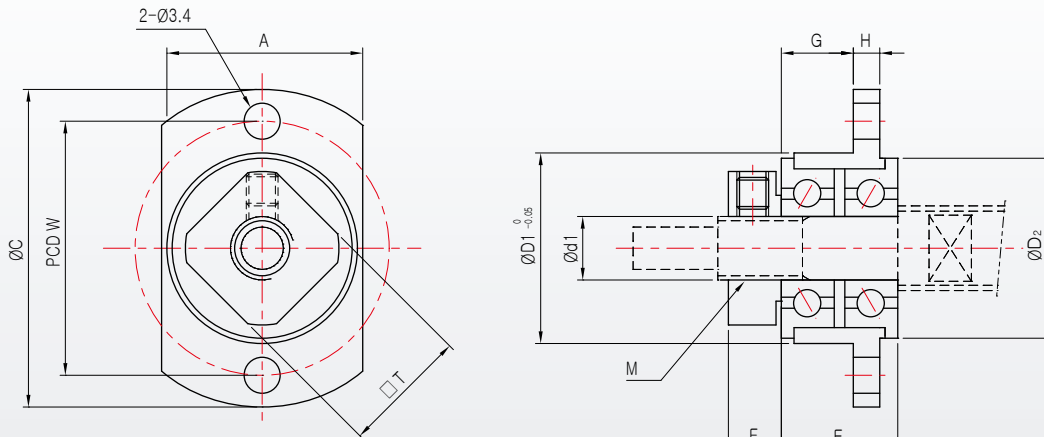

### Note

1. Tighten locknut as flange type miniature ball bearing can be slightly detached from surface due to vibration during operation.
2. A WBK Type is assembled by bolt for delivery.

Unit : mm

Model No.	d <sub>i</sub>	A	C	D <sub>1</sub>	D <sub>2</sub>	E	F	G	H	W	U	M	Space
WBK04	4	14	25	13	12.5	9	5	5	2.5	19	10	M4×0.5	ø8×ø4×1 - 1EA
WBK06	6	19	30	18	17	11	5	6.8	2.5	24	12	M6×0.75	ø9.1×ø6×1 - 1EA

### Kinds of Support Units and Outside Diameter of Applied Screw

Inner Diameter of Fixture (mm)	Application of Fixture Model No.	Inner Diameter of Support (mm)	Inner Diameter of Support	Outside diameter of applied Screw (mm)
4	EK4 / FK4	-	-	ø6
5	EK5 / FK5	-	-	ø8
6	BK6 / EK6 / FK6	ø6	BF6 / EF6 / FF6	ø8
8	AK8 / BK8 / EK8 / FK8	ø6	AF8 / BF8 / EF8 / FF8	ø10, ø12
10	AK10 / BK10 / EK10 / FK10	ø8	AF10 / BF10 / EF10 / FF10	ø14, ø15
12	AK12 / BK12 / EK12 / FK12	ø10	AF12 / BF12 / EF12 / FF12	ø16, ø18
15	AK15 / BK15 / EK15 / FK15	ø15	AF15 / BF15 / EF15 / FF15	ø20, ø25
17	BK17 / FK17	ø17	BF17 / FF17	ø25
20	AK20 / BK20 / EK20 / FK20	ø20	AF20 / BF20 / EF20 / FF20	ø28, ø30, ø32
25	BK25 / EK25 / FK25	ø25	BF25 / EF25 / FF25	ø36
30	BK30 / FK30	ø30	BF30 / FF30	ø40, ø45
35	BK35 / FK35	ø35	BF35 / FF35	ø45
40	BK40 / FK40	ø40	BF40 / FF40	ø50, ø55

# Sungil Support Units

## How to Order

### Fixture

**BK10**

Fixture Model No.  
(EK, BK, AK, FK)

**P5** (Grade : Precision)

**C8** (Grade : Preload)

**P0-C7** (Grade : Light Preload)

- P5 Type support unit is assembled by precision type bearing (preload and axial clearance is 0mm)
- C8 Type support unit is assembled by preload type bearing (preload and axial clearance is 0mm)
- P0-C7 Type support unit is assembled by general type bearing (light preload and axial clearance is 0mm)

### Support

**BF10**

Support Model No. (EF, BF, AF, FF)

Please, note that the type names and numbers for support part (EF, BF, AF, FF (No. 8, 10, 12) do not correspond to the internal diameter of bearing (Please, refer to page 45, 47, 49, 51)

TYPE name and number ≠ Internal diameter of bearing (EF, BF, AF, FF8=  $\phi$  6, EF, BF, AF, FF12=  $\phi$  10)

## Support Unit Characteristic Chart

Model No.	Bearing Type			Axial Direction	
	P5	C8	P0-C7	Rated Load Ca (Kgf)	Limited Load (kgf)
EK4 / FK4	-	-	634ZZ	-	-
EK5 / FK4	-	-	625ZZ	-	-
EK6	706ATYNDFMP5	-	606ZZ	250	110
BK6	-	-	EN6	-	-
EK8 / FK8	708ATYNDFMP5	-	EN8	410	150
BK8	-	-	EN8	-	-
AK8	708ATYNDFMP5	-	-	410	150
EK10 / BK10 / FK10 / AK10	7000ATYNDFMP5	7000AWDFM	7000AW	650	280
EK12 / BK12 / FK12 / AK12	7001ATYNDFMP5	7001AWDFM	7001AW	700	310
EK15 / BK15 / FK15 / AK15	7002ATYNDFMP5	7002AWDFM	7002AW	750	350
BK17, FK17	7203ATYNDFMP5	7203AWDFM	7203AW	1300	590
EK20 / FK20 / AK20	7204ATYNDFMP5	7204AWDFM	7204AW	1750	840
BK20	7004ATYNDFMP5	7004AWDFM	7004AW	1610	840
EK25 / BK25 / FK25	7205ATYNDFMP5	7205AWDFM	7205AW	1960	1010
BK30 / FK30	7206ATYNDFMP5	7206AWDFM	7206AW	2730	1340
BK35 / FK35	7207ATYNDFMP5	7207AWDFM	7207AW	3560	1840
BK40 / FK40	7208ATYNDFMP5	7208AWDFM	7208AW	4250	2290

## Bearing Combination

There are DB combination and DF combination in combination way of angular bearing. SI Support Unit is DF combination.

### DB Combination

- The point distance of action is long. So stiffness is big when moment load is affected. It is easy to get flaking damaged because of increase of inner load in case of misalignment.

### DF Combination

- The point distance of action is short. So stiffness is not good when moment load is affected. DF combination is normal type because acceptable rate of misalignment is good.

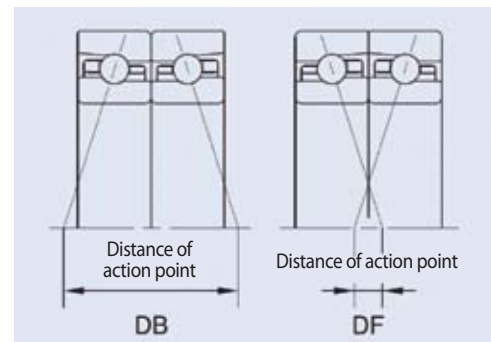

# SJU Type Joint Unit

## Support Unit + Servo Motor Mount Plate

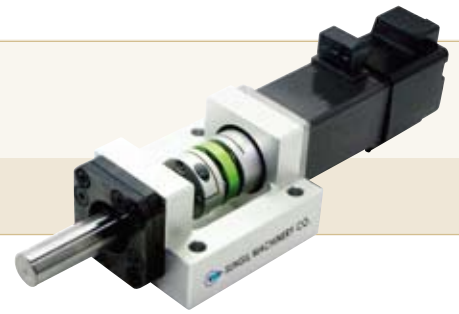

### Features

- **Simple assembly** : It is easy to assembly the motor by joint because of built-in servo unit.
  - **High precision** : Some error of each shaft can be eliminated because ball screw part and motor part is monolithic structure.
- ※ **Notice** : There are two kinds of PCD according to servo motor specification. Therefore please check this part when you order.

### SJU 8 ~ 15

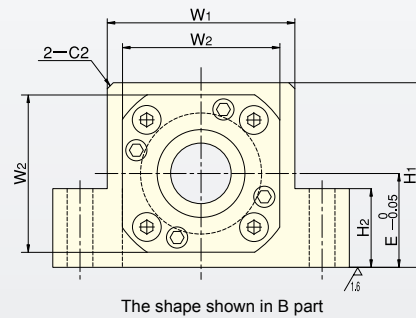
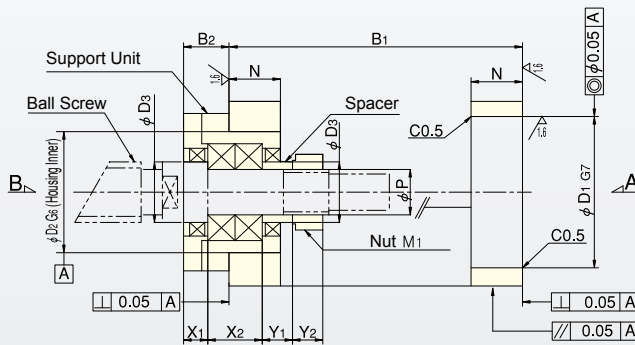
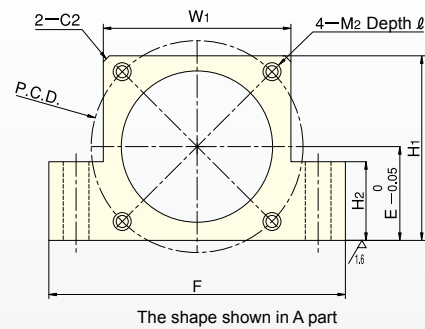
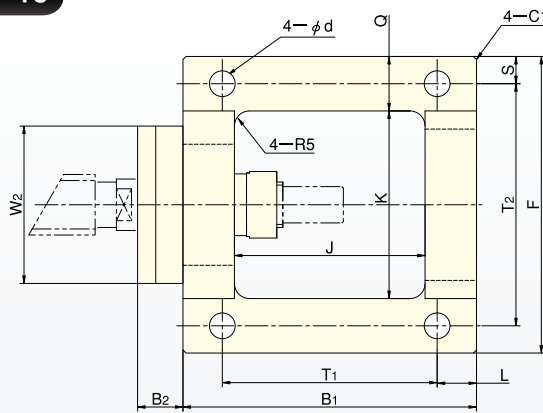

Unit : mm

Model Name	Model No.	P	B <sub>1</sub>	B <sub>2</sub>	D <sub>1</sub>	D <sub>2</sub>	D <sub>3</sub>	E	F	H <sub>1</sub>	H <sub>2</sub>	J	K	L	N	Q	S	T <sub>1</sub>	T <sub>2</sub>	W <sub>1</sub>	W <sub>2</sub>	X <sub>1</sub>	X <sub>2</sub>	Y <sub>1</sub>	Y <sub>2</sub>	PCD	M <sub>1</sub>	M <sub>2</sub>	d	l	Snap Ring	
SJU	8A	8	67	9	30	28	11	21	64	41	19	43	40	10	12	12	6	47	52	40	35	5	14	5.5	6.5	45	M8×1	M3	5.5	8	10	FK8
	8B																											M4				
	10A	10	74	13	30	34	14	25	70	46	23	46	42	10	14	14	7	54	56	42	42	8	16	5.5	8	45	M10×1	M3	6.5	8	10	FK10
	10B																											M4				
	12A	12	74	13	30	36	15.1	25	72	47	23	46	44	10	14	14	7	54	58	44	44	8	16	5.5	8	45	M12×1	M3	6.5	8	10	FK12
	12B																											M4				
15	15	97	15	50	40	20	31	98	61	26	63	62	13	17	18	9	71	80	62	52	8	18	10	8	70	M15×1	M5	8.5	13	FK15		

※ Please refer to catalog if you want to find SI coupling that is compatible with SI Joint Unit.



# SBJU Type Joint Unit

## Support Unit + Servo Motor Mount Plate



Please, download CAD DATA on [www.sungilfa.com](http://www.sungilfa.com)

### Features

- **Simple assembly** : It is easy to assembly the motor by joint because of built-in servo unit.
  - **High precision** : Some error of each shaft can be eliminated because ball screw part and motor part is monolithic structure.
  - **Angular contact ball bearing** is inserted into SBJU Type.
- ※ **Notice** : There are two kinds of PCD according to servo motor specification. Therefore please check this part when you order.

### SBJU 8 ~ 15

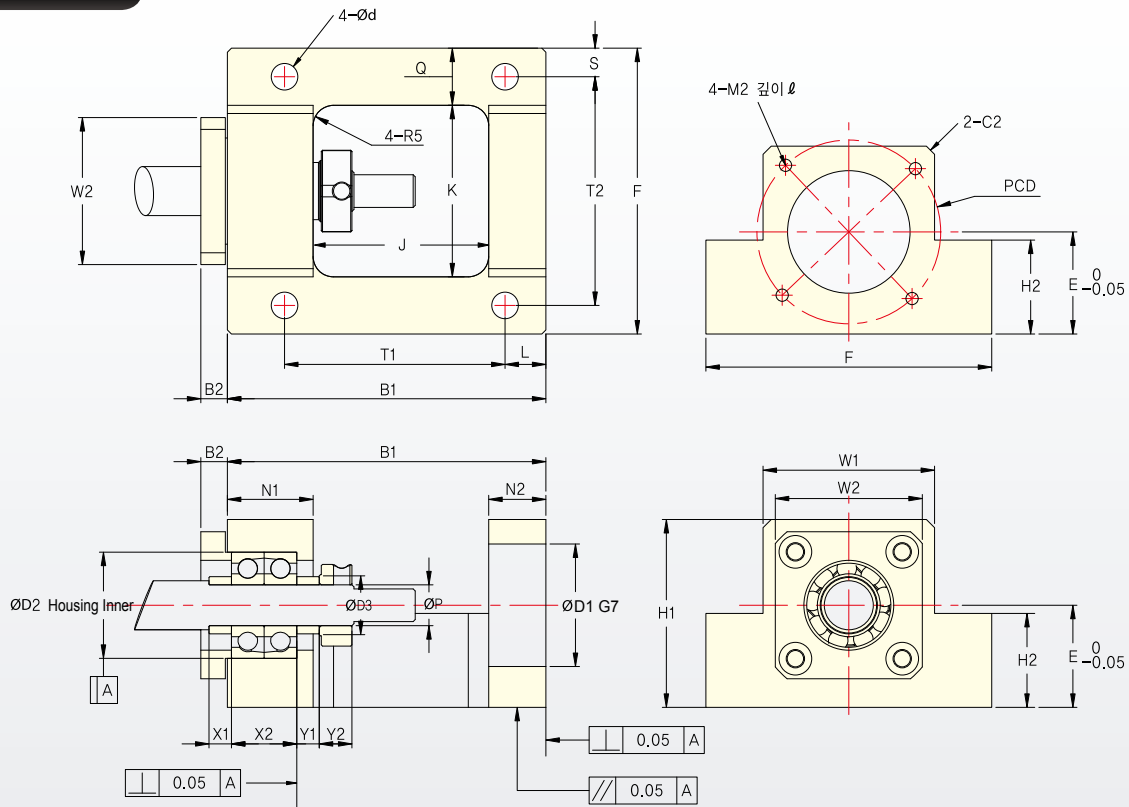

Unit : mm

Model Name	Model No.	P	B <sub>1</sub>	B <sub>2</sub>	D <sub>1</sub>	D <sub>2</sub>	D <sub>3</sub>	E	F	H <sub>1</sub>	H <sub>2</sub>	J	K	L	N <sub>1</sub>	N <sub>2</sub>	Q	S	T <sub>1</sub>	T <sub>2</sub>	W <sub>1</sub>	W <sub>2</sub>	X <sub>1</sub>	X <sub>2</sub>	Y <sub>1</sub>	Y <sub>2</sub>	PCD	M <sub>1</sub>	M <sub>2</sub>	d	l
SBJU	8A	8	73	6.5	30	24	11	21	64	41	19	42	40	10	19	12	12	6	47	52	40	34	7.5	14	5.5	6.5	45	M8×1	M3	5.5	8
	8B					(22)																					46	M4		10	
	10A	10	79	6.5	30	26	14	25	70	46	23	44	42	10	21	14	14	7	54	56	42	36	5.5	16	5.5	8	45	M10×1	M3	6.5	8
	10B																										46	M4		10	
	12A	12	79	6.5	30	28	15.1	25	72	47	23	44	44	10	21	14	14	7	54	58	44	36	5.5	16	5.5	8	45	M12×1	M3	6.5	8
	12B																										46	M4		10	
	15	15	105	6.5	50	32	20	31	98	61	26	65	62	13	23	17	18	9	71	80	62	40	10	18	10	8	70	M15×1	M5	8.5	13

※ Please refer to catalog if you want to find SI coupling that is compatible with SI Joint Unit.

# Bearing Unit

Please, download CAD DATA on [www.sungilfa.com](http://www.sungilfa.com)

## Single Bearing Type

SBS - ■ ■ ■

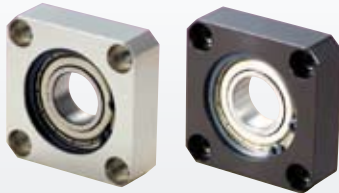

Example (Single Bearing Type)

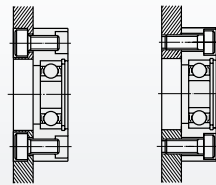

<Use the Tap>   <Use the Count bore>

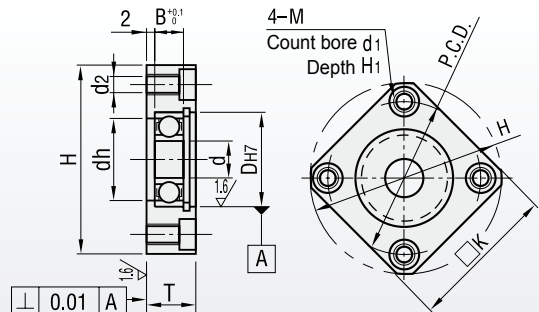

## Standards

Standards	$\phi d$	$\phi D_{H7}$	B	$\phi H$	$\square K$	T	dh	PCD	M	$\phi d_2$	$\phi d_1$	$H_1$	Bearing
SBS-8	8	22	7	45	36	12	18	35	5	4.3	8	4.4	608ZZ
SBS-10	10	26	8	50	39	13	22	40	5	4.3	8	4.4	6000ZZ
SBS-12	12	28	8	52	40	13	24	42	5	4.3	8	4.4	6001ZZ
SBS-15	15	32	9	60	46	14	28	48	6	5.2	9.5	5.4	6002ZZ
SBS-17	17	40	12	72	54	18	34	60	6	5.2	9.5	5.4	6203ZZ
SBS-20	20	42	12	77	59	18	36	64	8	6.8	11	6.5	6004ZZ
SBS-25	25	52	15	94	72	22	45	78	10	8.5	14	8.6	6205ZZ
SBS-30	30	62	16	104	79	23	55	88	10	8.5	14	8.6	6206ZZ

## Double Bearing Type

SBD - ■ ■ ■

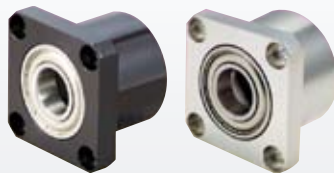

Example (Double Bearing Type)

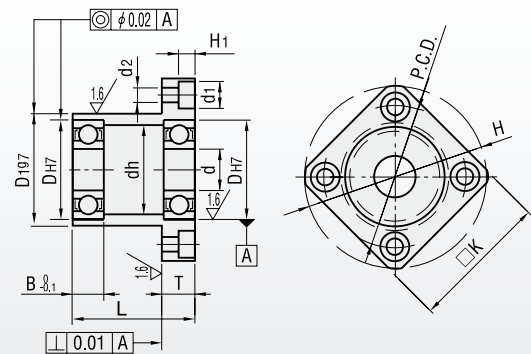
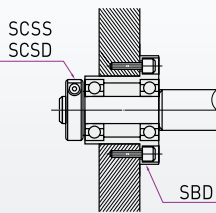

## Standards

Standards	$\phi d$	$\phi D_{H7}$	$\phi D_1 g_7$	B	L	$\phi H$	$\square K$	T	dh	PCD	$\phi d_2$	$\phi d_1$	$H_1$	Bearing
SBD-8	8	22	27	7	25	45	36	8	18	35	4.3	8	4.4	608ZZ
SBD-10	10	26	32	8	30	50	39	8	22	40	4.3	8	4.4	6000ZZ
SBD-12	12	28	34	8	30	52	40	8	24	42	4.3	8	4.4	6001ZZ
SBD-15	15	32	38	9	35	60	46	10	28	48	5.2	9.5	5.4	6002ZZ
SBD-17	17	40	48	12	45	72	54	10	34	60	5.2	9.5	5.4	6203ZZ
SBD-20	20	42	50	12	45	77	59	11	36	64	6.8	11	6.5	6004ZZ
SBD-25	25	52	60	15	45	94	72	13	45	78	8.5	14	8.6	6205ZZ
SBD-30	30	62	70	16	50	104	79	13	55	88	8.5	14	8.6	6206ZZ

# Set Collars

Please, download CAD DATA on [www.sungilfa.com](http://www.sungilfa.com)

## Set Collars - Split Type

SCSD - ■ ■

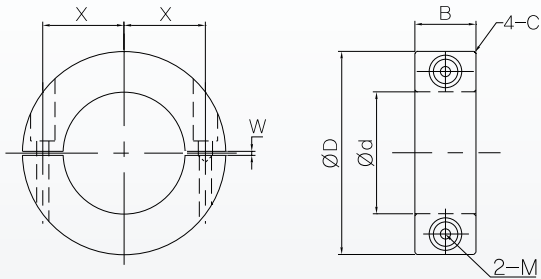

## Set Collars - Slit Type

SCSS - ■ ■

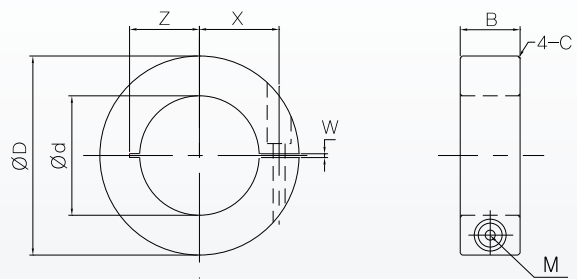

### Standards

Standards	ø d	ø D	B	C	W	M	X
SCSD-6	6	20	8	0,3	1	M3	6
SCSD-8	8	25	10	0,3	1	M4	8
SCSD-10	10	35	12	0,3	1,5	M5	10
SCSD-12	12	35	15	0,5	1,5	M6	11
SCSD-13	13	35	15	0,5	1,5	M6	11,5
SCSD-15	15	40	15	0,5	1,5	M6	13
SCSD-16	16	40	15	0,5	1,5	M6	13
SCSD-17	17	40	15	0,5	1,5	M6	13
SCSD-18	18	40	15	0,5	1,5	M6	15
SCSD-20	20	45	15	0,5	1,5	M6	15
SCSD-25	25	50	15	0,5	1,5	M6	18
SCSD-30	30	55	15	1	1,5	M6	20

### Standards

Standards	ø d	ø D	B	C	W	M	X	Z
SCSS-6	6	20	8	0,3	1	M3	6	6-6,5
SCSS-8	8	25	10	0,3	1	M4	8	7-9
SCSS-10	10	35	12	0,3	1,5	M5	10	8-10
SCSS-12	12	35	15	0,5	1,5	M6	11	10-12
SCSS-13	13	35	15	0,5	1,5	M6	11,5	10-12
SCSS-15	15	40	15	0,5	1,5	M6	13	11-13
SCSS-16	16	40	15	0,5	1,5	M6	13	11-13
SCSS-17	17	40	15	0,5	1,5	M6	13	11-13
SCSS-18	18	40	15	0,5	1,5	M6	15	13-15
SCSS-20	20	45	15	0,5	1,5	M6	15	13-15
SCSS-25	25	50	15	0,5	1,5	M6	18	16-18
SCSS-30	30	55	15	1	1,5	M6	20	18-20

Example (Set Collars - Split Type)

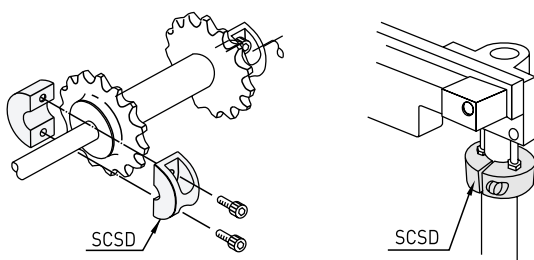

Example (Set Collars - Slit Type)

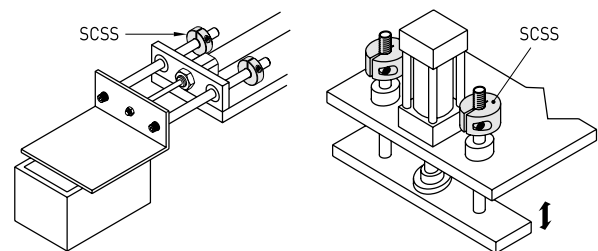

# Lock Nut



## Note

1. Locknut can be used by connecting ball screw to bearing with high accuracy.
2. The set piece connected to the stop screw ensures tight connection while preventing locknut from being loosened.

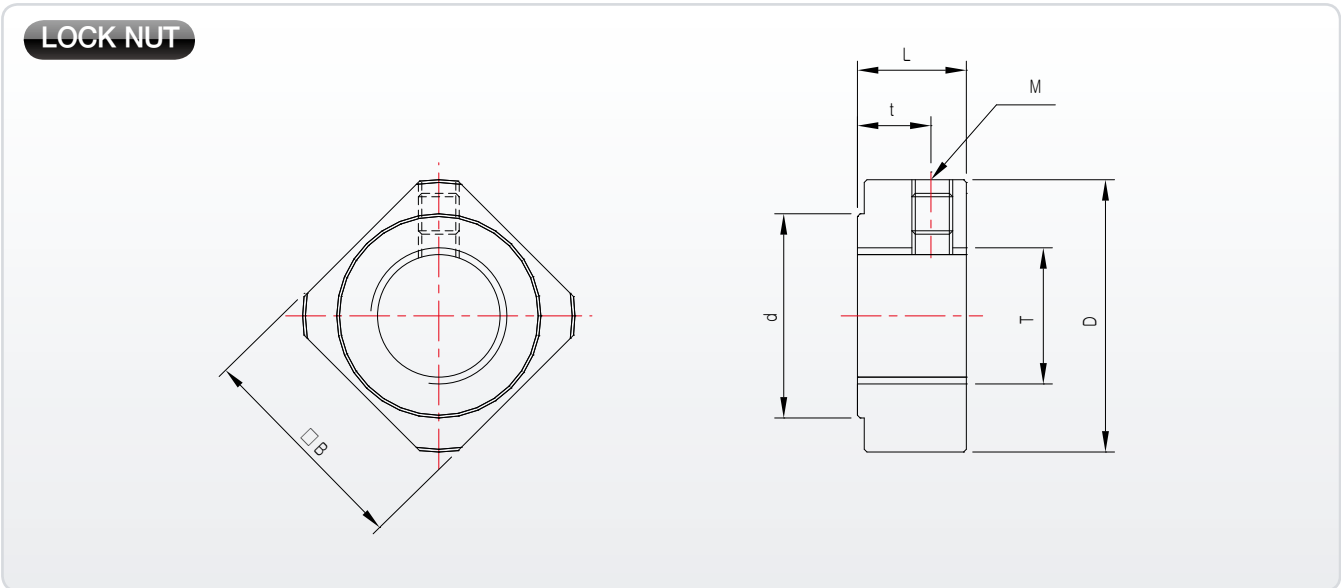

Unit : mm

Model No.	T	M	D	d	L	t	□B	Attachment Torque (Reference) (kgf.cm)
RN4	M4×0,5	M3×0,5	11	8,5	5	2,7	10	16
RN5	M5×0,5	M3×0,5	13	9	5	2,7	11	20
RN6	M6×0,75	M3×0,5	14,5	10	5	2,7	12	25
RN8	M8×1	M3×0,5	17	13	6,5	4	14	50
	★ M8×0,75							
RN10	M10×1	M4×0,7	20	15	8	5,5	16	95
	★ M10×0,75							
RN12	M12×1	M4×0,7	22	17	8	5,5	19	140
RN15	M15×1	M4×0,7	25	21	8	4,5	22	240
RN17	M17×1	M4×0,7	30	25	13	9	24	350
RN20	M20×1	M4×0,7	35	26	11	7	30	480
RN25	M25×1,5	M5×0,8	43	33	15	10	35	860
RN30	M30×1,5	M6×1	48	39	20	14	40	1,280
RN35	M35×1,5	M8×1,25	60	46	21	14	50	1,920
RN40	M40×1,5	M8×1,25	63	51	25	18	50	2,560

※ The product marked ★ is order specification.

# *Power Lock*



# Power Lock SAPC Series

## Sungil Aluminium Power Lock



### Features

#### 1. Aluminum Material

It is important to reduce the moment of inertia for high speed servo motor controlled positioning. It is possible by using the suitable aluminum power lock to realize low moment of inertia with high speed.

#### 2. Suitable for Aluminum Pulley

There was slipping problem with servo motor with timing pulley driving caused by mismatch of hub diameter, which ordinal frictional connection unit has high surface pressure. SAPC series are limited for servo motor torque and reduce the surface pressure to bore by reducing the screws.

#### 3. New suggestion Bearing positioning construction

Bearing construction is on Power Lock. Bearing positioning stopper is unnecessary

#### 4. Easy operation for installation positioning

We have been suggested to leave the 1mm space for the installation before to concern the uninstal situation. However SAPC series provide smooth uninstal operation by positioning stopper. Also positioning is easy with it.

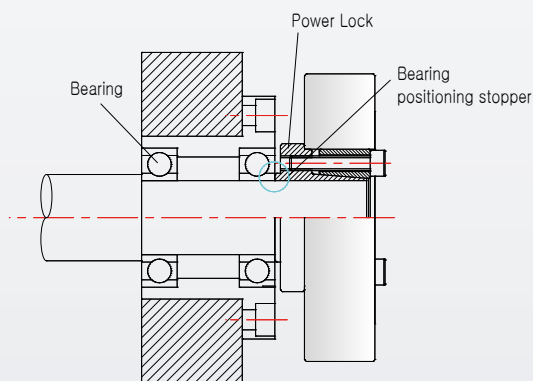

※ Be careful for deciding the hub outer diameter with aluminum alloy strength, which may modulus of direct elasticity be low.

※ Contact us for the combination of aluminum alloy and steel shaft installation with over 80 °C circumstances. It may cause of torque reduction at high temperature

### Structure & Material

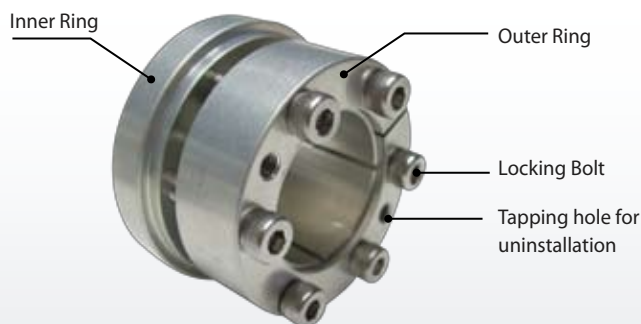

	Material	Surface Treatment
Inner Ring	Aluminum Alloy	Alumite
Outer Ring	Aluminum Alloy	Alumite
Locking Bolt	SCM 435	Electroless Nickel Coating

# SAPC Series

## Sungil Aluminium Power Lock

### Specification

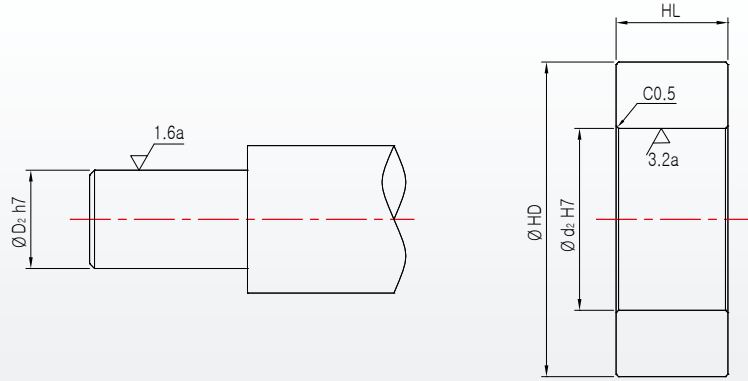

Shaft and Hub Dimension

Model No.	Max Allowance Torque (N,m)	Allowance Trust Load (kN)	Surface pressure		Moment of Inertia (kg/m <sup>2</sup> )	Shaft and Hub Dimension				
			Shaft(N/mm <sup>2</sup> )	Hub(N/mm <sup>2</sup> )		Dimension			Hub Minium OD (HD)	
						D <sub>2</sub>	d <sub>2</sub>	HL	Aluminum	S45C
SAPC-5-16	2,5	1,00	121	35	2,65 x 10 <sup>-7</sup>	5	16	9	20	19
SAPC-6-17	4	1,33	151	49	3,31 x 10 <sup>-7</sup>	6	17	9	23	21
SAPC-8-19	6	1,51	129	51	5,95 x 10 <sup>-7</sup>	8	19	10	26	24
SAPC-10-21	8	1,63	104	46	8,52 x 10 <sup>-7</sup>	10	21	10	29	26
SAPC-11-22	9	1,66	88	41	1,08 x 10 <sup>-6</sup>	11	22	11	30	26
SAPC-12-24	12	1,99	89	42	1,62 x 10 <sup>-6</sup>	12	24	12	33	29
SAPC-14-26	18	2,56	91	47	2,16 x 10 <sup>-6</sup>	14	26	12	38	31
SAPC-15-28	25	3,34	79	38	3,18 x 10 <sup>-6</sup>	15	28	13	40	33
SAPC-16-29	26	3,34	74	37	3,50 x 10 <sup>-6</sup>	16	29	13	41	34
SAPC-17-30	27	3,18	66	34	4,23 x 10 <sup>-6</sup>	17	30	14	42	35
SAPC-18-31	29	3,23	78	41	4,75 x 10 <sup>-6</sup>	18	31	14	46	36
SAPC-19-32	33	3,50	74	40	5,32 x 10 <sup>-6</sup>	19	32	14	49	37
SAPC-20-37	54	5,47	92	46	1,06 x 10 <sup>-5</sup>	20	37	16	54	44
SAPC-22-39	65	5,94	83	43	1,33 x 10 <sup>-5</sup>	22	39	16	56	46
SAPC-24-41	85	7,07	84	46	1,67 x 10 <sup>-5</sup>	24	41	18	59	48
SAPC-25-42	110	8,77	97	53	2,08 x 10 <sup>-5</sup>	25	42	19	64	51
SAPC-28-45	125	8,91	101	57	2,65 x 10 <sup>-5</sup>	28	45	19	72	55
SAPC-30-50	180	12,08	99	56	4,46 x 10 <sup>-5</sup>	30	50	20	76	60
SAPC-32-53	210	13,13	104	59	5,55 x 10 <sup>-5</sup>	32	53	20	81	65
SAPC-35-56	230	13,13	92	54	7,61 x 10 <sup>-5</sup>	35	56	22,5	85	67

※ Hub outer diameter with aluminum alloy strength, which may modulus of direct elasticity is low so sometimes it is impossible to secure enough hub outer diameter with aluminum alloy strength.

※ Transmission reduce 15-20% about keyway type because of reduction of contact surface

# SAPC Series

Please, download CAD DATA on [www.sungilfa.com](http://www.sungilfa.com)

## Dimension

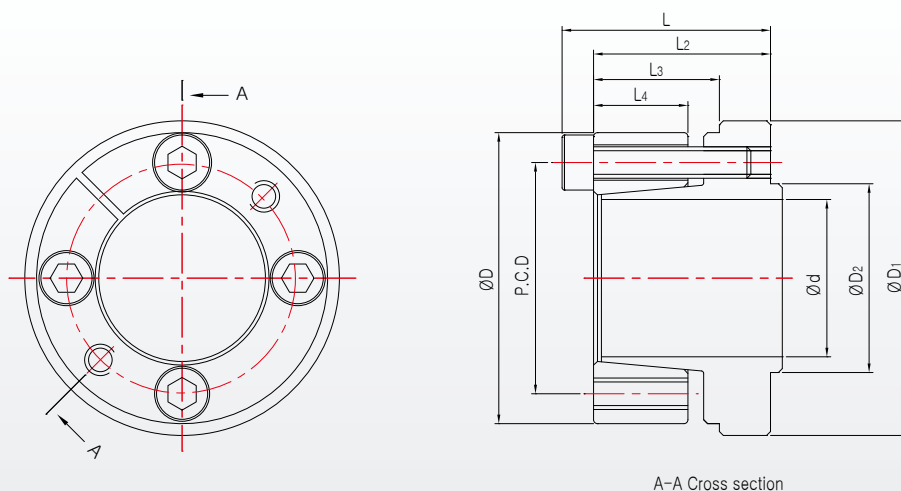

Model No. (dxD)	Dimension (mm)							Attachment Bolt			Mess (g)
	L	L <sub>2</sub>	L <sub>3</sub>	L <sub>4</sub>	D <sub>1</sub>	D <sub>2</sub>	P.C.D	Size	Quantity	Attachment Torque (N,m)	
SAPC-5-16	15,5	13	9	6,5	19	7,5	11,1	M2,5	2	1,0	7
SAPC-6-17	15,5	13	9	6,5	20	8,5	12,1	M2,5	3	1,0	8
SAPC-8-19	17,5	15	10	7,5	22	11	14,1	M2,5	4	1,0	11
SAPC-10-21	17,5	15	10	7,5	24	13	16,1	M2,5	4	1,0	12
SAPC-11-22	19,5	17	11	8	25	14	17,1	M2,5	4	1,0	14
SAPC-12-24	20,5	18	12	9	27	15	19,2	M2,5	5	1,0	17
SAPC-14-26	20,5	18	12	9	29	17	21,2	M2,5	6	1,0	19
SAPC-15-28	23	20	13	9,5	31	18,5	22,2	M3	4	1,9	24
SAPC-16-29	23	20	13	9,5	32	19,5	23,2	M3	4	1,9	25
SAPC-17-30	24	21	14	10	33	20,5	24	M3	4	1,9	28
SAPC-18-31	24	21	14	10	34	21,5	25	M3	5	1,9	29
SAPC-19-32	24	21	14	10	35	22,5	26	M3	5	1,9	30
SAPC-20-37	28	24	16	12	40	24	29,4	M4	4	3,9	47
SAPC-22-39	28	24	16	12	42	26	31,4	M4	4	3,9	52
SAPC-24-41	30	26	18	13	45	28	33,3	M4	5	3,9	57
SAPC-25-42	32	28	19	13,5	46	29	34,3	M4	6	3,9	67
SAPC-28-45	32	28	19	13,5	49	32	37,3	M4	7	3,9	73
SAPC-30-50	35	30	20	14,5	55	34,5	40,8	M5	5	8,8	101
SAPC-32-53	35	30	20	14,5	58	36,5	43,3	M5	6	8,8	112
SAPC-35-56	38	33	22,5	16	62	40	46,6	M5	6	8,8	134



# Power Lock SAPA Series

## Sungil Aluminium Power Lock



### Features

#### 1. Aluminum Material

It is important to reduce the moment of inertia for high speed servo motor controlled positioning. It is possible by using the suitable aluminum power lock to realize low moment of inertia with high speed.

#### 2. High Torque Transmission

It is possible to use this type in aluminum pulley and also steel pulley because it is made by aluminum alloy and it is possible to transfer high torque.

#### 3. The optimum in clean room

SAPA is made by aluminum alloy and nickel coating bolt so is optimum in clean room

- ※ Be careful for deciding the hub outer diameter with aluminum alloy strength, which may modulus of direct elasticity be low
- ※ Contact us for the combination of aluminum alloy and steel shaft installation with over 80 ° circumstances. It may cause of torque reduction at high temperature

### Structure & Material

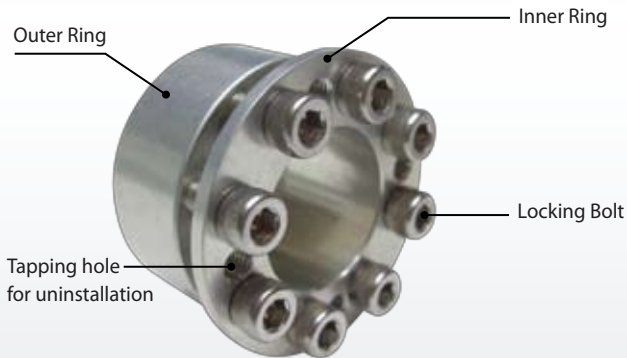

	Locking Bolt	Surface Treatment
Inner Ring	Aluminum Alloy	Alumite
Outer Ring	Aluminum Alloy	Alumite
Locking Bolt	SCM 435	Electroless Nickel Coating

### Attachment Principle

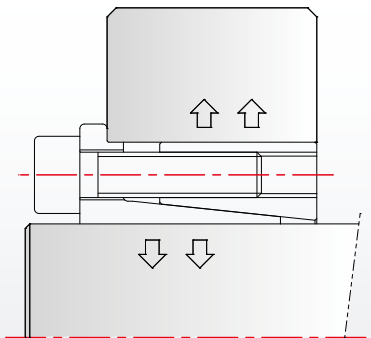

### How to Order

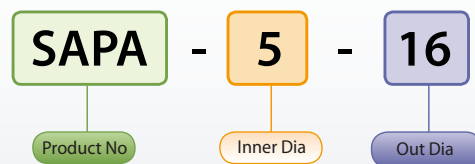

# SAPA Series

Please, download CAD DATA on [www.sungilfa.com](http://www.sungilfa.com)

## Specification

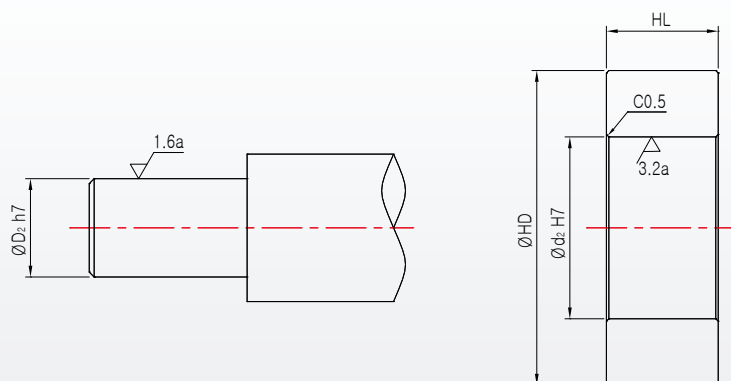

Shaft and Hub Dimension

Model No.	Max Allowance Torque (N,m)	Allowance Trust Load (kN)	Surface pressure		Moment of Inertia (kg/m <sup>2</sup> )	Shaft and Hub Dimension				
			Shaft(N/mm <sup>2</sup> )	Hub(N/mm <sup>2</sup> )		Dimension			Hub Minium OD (HD)	
						D <sub>2</sub>	d <sub>2</sub>	HL	Aluminum	S45C
SAPA-5-16	6	2,24	197	64	$2,63 \times 10^{-7}$	5	16	13	28	22
SAPA-6-19	11	3,74	285	92	$6,13 \times 10^{-7}$	6	17	14	35	27
SAPA-8-21	18	4,48	214	96	$8,74 \times 10^{-7}$	7	19	15	39	30
SAPA-10-23	20	4,48	167	86	$1,23 \times 10^{-6}$	10	21	16	41	32
SAPA-11-24	24	4,48	153	83	$1,44 \times 10^{-6}$	11	22	16	42	33
SAPA-12-26	40	6,73	209	103	$2,38 \times 10^{-6}$	12	24	17	50	38
SAPA-14-28	52	7,57	202	108	$3,08 \times 10^{-6}$	14	26	17	56	42
SAPA-15-29	56	7,57	167	95	$3,66 \times 10^{-6}$	15	28	18	53	41
SAPA-16-30	60	7,57	149	88	$4,28 \times 10^{-6}$	16	29	18	54	42
SAPA-17-31	88	10,08	177	109	$5,13 \times 10^{-6}$	17	30	19	61	46
SAPA-18-32	92	10,08	167	106	$5,71 \times 10^{-6}$	18	31	19	62	47
SAPA-19-33	96	10,08	159	102	$7,20 \times 10^{-6}$	19	32	19	63	48
SAPA-20-38	176	17,28	186	111	$1,55 \times 10^{-5}$	20	37	23	82	60
SAPA22-40	232	20,80	204	126	$1,84 \times 10^{-5}$	22	39	23	96	68
SAPA-24-42	256	20,80	173	113	$2,23 \times 10^{-5}$	24	41	24	92	67
SAPA-25-43	280	21,76	172	109	$2,49 \times 10^{-5}$	25	42	25	91	67
SAPA-28-46	304	21,60	153	101	$3,36 \times 10^{-5}$	28	45	25	92	69
SAPA-30-48	328	21,60	142	97	$3,86 \times 10^{-5}$	30	50	25	94	71
SAPA-32-50	352	21,60	124	88	$4,60 \times 10^{-5}$	32	53	26	92	71
SAPA-35-57	576	32,88	195	132	$8,46 \times 10^{-5}$	35	56	28	121	89

※ Hub outer diameter with aluminum alloy strength, which may modulus of direct elasticity is low so sometimes it is impossible to secure enough hub outer diameter with aluminum alloy strength.

※ Transmission reduce 15-20% about keyway type because of reduction of contact surface

# SAPA Series

## Sungil Aluminium Power Lock

### Dimension

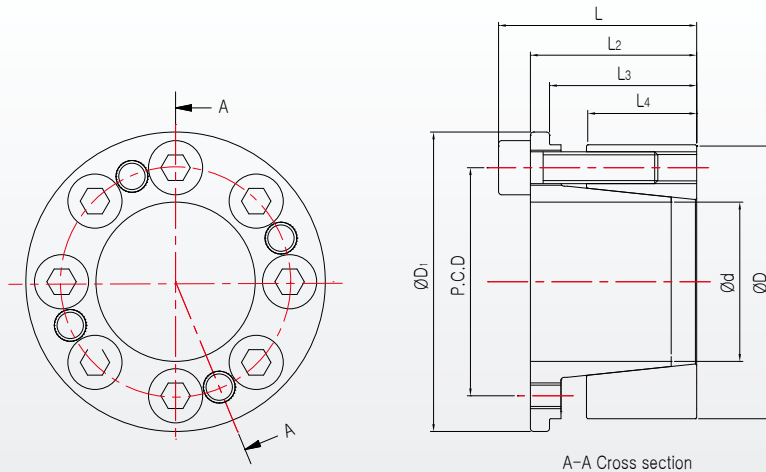

Model No.	Dimension (mm)						Attachment Bolt			Mess (g)
	L	L <sub>2</sub>	L <sub>3</sub>	L <sub>4</sub>	D <sub>1</sub>	P.C.D	Size	Quantity	Attachment Torque (N,m)	
SAPA-5-16	16	13	11,2	6,5	18,5	11,7	M3	4	1,9	7
SAPA-6-19	18,3	14,3	12,3	6,5	21,5	14	M4	4	3,9	10
SAPA-8-21	18,6	14,6	12,6	6,5	23,5	15,4	M4	4	3,9	13
SAPA-10-23	18,8	14,8	12,8	6,5	25,5	17,5	M4	4	3,9	15
SAPA-11-24	19,8	15,8	13,8	7,5	26,5	18,4	M4	4	3,9	17
SAPA-12-26	22	18	15,5	7,5	28,5	20,2	M4	6	3,9	20
SAPA-14-28	22	18	15,5	8	30,5	22,2	M4	6	3,9	23
SAPA-15-29	23	19	16,5	9	31,5	23,2	M4	6	3,9	25
SAPA-16-30	23,6	19,6	17,1	9	33	24,2	M4	6	3,9	28
SAPA-17-31	24,1	20,1	17,6	9,5	33,5	25,2	M4	8	3,9	28
SAPA-18-32	24,1	20,1	17,6	9,5	34,5	26,2	M4	8	3,9	30
SAPA-19-33	24,1	20,1	17,6	10	35,5	27,2	M4	8	3,9	31
SAPA-20-38	29,1	24,1	21,1	10	42	30,8	M5	8	8,8	53
SAPA22-40	29,1	24,1	21,1	10	44	32,8	M5	8	8,8	60
SAPA-24-42	30,1	25,1	22,1	12	46	34,8	M5	8	8,8	65
SAPA-25-43	31,1	26,1	23,1	12	47	35,8	M5	8	8,8	68
SAPA-28-46	31,6	26,6	23,1	13	50	38,8	M5	10	8,8	71
SAPA-30-48	31,6	26,6	23,1	13,3	52	40,8	M5	10	8,8	76
SAPA-32-50	32,6	27,6	24,1	13,5	54	42,8	M5	10	8,8	80
SAPA-35-57	36	30	26	14,5	55	48,4	M6	8	15,7	117

# Power Lock SAPC/SAPA Series

Please, download CAD DATA on [www.sungilfa.com](http://www.sungilfa.com)

## Caution of installation

1. Please be clean installation inner diameter surface of power lock.
2. After install of power lock to shaft, and insert to the hub, which processed in selected dimension. Confirm the hub edge perfectly attached to flange. Confirm the depth by depth gage or caliper if it is difficult to judge by sight. If there is a gap at connection, power lock flange may be deformed and it is impossible to use deformed product again.

Confirm the hub edge attachment

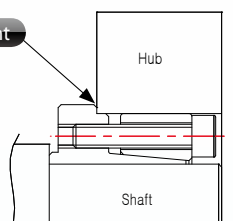

3. The inner ring taper and outer ring taper are stacking together by transportation and hard to insert the shaft and hub, loose the locking screws and disassemble the taper parts of power lock by using disassemble screw.

4. Tighten slowly and evenly in diagonal direction by 1/4 tightening torque after checking there are no gap between flange edge and hub. Next please increase to tightening torque, and finally please tighten by tightening torque of catalog. Also confirm the tightening torque is right for all screws and if there is not loosen bolt.

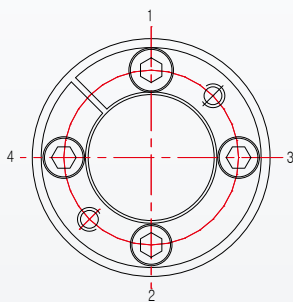

5. When you disassemble the power lock, please disassemble slowly by loosening screw in diagonal direction. If you don't disassemble step by step by using disassemble bolt hole, inner ring is deformed and it is impossible to use deformed product again.

Tapping hole for uninstallation

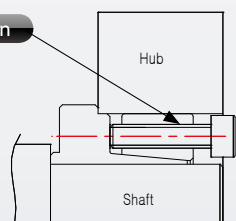

## Installation Guide

### Torque

Calculate the torque from r.p.m and motor torque line when you found motor capacity, there is reduction gear or not, and reduction gear rate. If there is no information of motor, then please use the standard formula below.

$$T_{max} = \frac{9550 \cdot P_{max}}{N} \times R \times K$$

$T_{max}$  : Generated Torque [N · m]

$P_{max}$  : Motor Capacity [kW]

$N$  : Rotation Speed [rpm]

$R$  : Reverse number of reduction gear

$K$  : Safe Factor

Factor of Load		K
Small inertia	Application is under 60% of motor rated torque.	1.5~2.0
Medium inertia	Long time for speeding up and reducing, or reversing operation is limited.	2.0~3.0
Large inertia	Rapid speed reduction and impact or frequent reversing.	3.0~5.0

### Thrust Load

Calculate by using general formula below when it has torque and thrust load together and compare with allowable maximum torque capacity of Power Lock

$$T_s = \sqrt{\left(\frac{9550 \cdot P_{max}}{N}\right)^2 + \left(\frac{H \cdot d}{2000}\right)^2} \cdot K$$

$T_s$  : Combined Load [N · m]

$H$  : Thrust Load [N]

$d$  : Inner Size [mm]

$K$  : Safe Factor



※Product design and specification are subject to change without notice for product improvement.



**SUNGIL MACHINERY CO., LTD.**

[www.sungilfa.co.kr](http://www.sungilfa.co.kr) / [www.sungilfa.com](http://www.sungilfa.com)

Main Office and factory

162-6, 12 Sinjung-dong Yangcheon-gu Seoul Korea 158-070 / TEL: +82-2-2635-7161 / FAX: +82-2635-7162

E-mail: [info@sungilfa.co.kr](mailto:info@sungilfa.co.kr) / URL: [www.sungilfa.com](http://www.sungilfa.com)

Overseas Sales Dept.

TEL: +82-2-2613-9933 / FAX: +82-2-2613-8911 / E-mail: [sales@sungilfa.co.kr](mailto:sales@sungilfa.co.kr)

Domestic Sales Office

#3309~11 Ga-dong Chungang Circulation Complex 1258 Gurobon-dong Guro-gu Seoul Korea 152-721

TEL: +82-2-2613-9933 / FAX: +82-2613-8911 / E-mail: [master@si-coupling.co.kr](mailto:master@si-coupling.co.kr) / URL: [www.sungilfa.co.kr](http://www.sungilfa.co.kr)



Inquiry

TEL: +82-2-2613-9933 / FAX: +82-2-2613-8911 / URL: [www.sungilfa.com](http://www.sungilfa.com) / E-mail: [sales@sungilfa.co.kr](mailto:sales@sungilfa.co.kr)