

Global Sales & Service Network

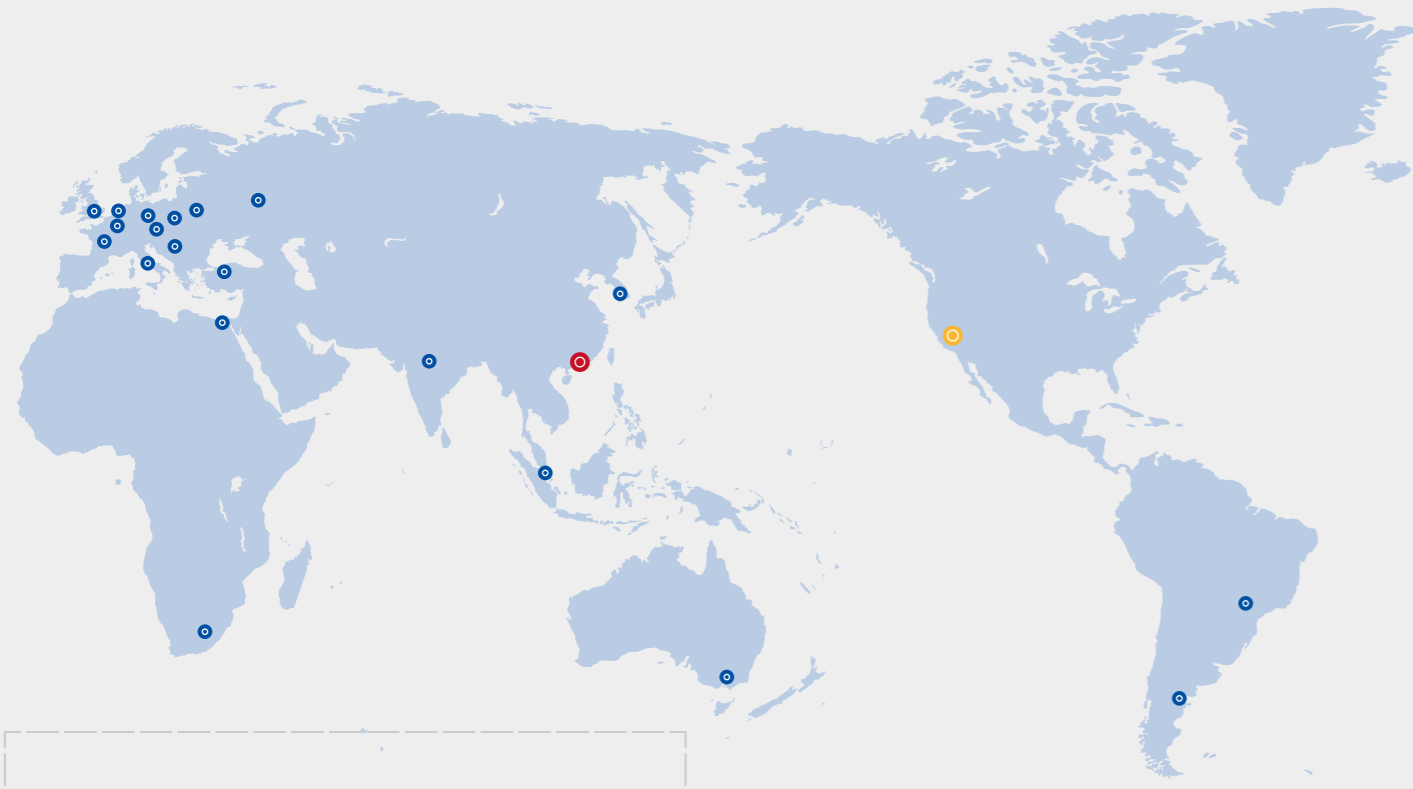

STEPPER PRODUCTS

- Stepper Drives
- Stepper Motors
- Closed Loop Stepper Drives
- Closed Loop stepper Motors
- Integrated Stepper Motors
- Integrated Closed Loop Stepper Motors
- Gearboxes
- Power Supplies



Headquarters

Leadshine Technology Co., Ltd.

Address: 15-20/F, Block B, Nanshan I Valley, No.3157,
Shahe West Road, Nanshan District, Shenzhen,
Guangdong, China
Tel: +86 755 26411692
Fax: +86 755 26402718
Website: www.leadshine.com
Emails: sales@leadshine.com (Sales)
tech@leadshine.com(Technical Support)

North America Office

Leadshine America, Inc.

Address: 26050 Towne Centre Dr.
Foothill Ranch, CA 92610
USA
Tel: 1-949-608-7270
Fax: 1-949-638-7298
Website: www.Leadshineusa.com
Emails: sales@leadshineusa.com(Sales)
tech@leadshineusa.com(Technical Support)



Company Profile

Founded in 1997 by Warren Li, a MIT PhD graduate.

Leadshine Technology Co., Ltd. is a leading technology company dedicated to designing, manufacturing, marketing, and selling affordable high performance motion control products based on the latest control technologies.

Our products include stepper and closed loop stepper products & AC servo products, integrated stepper & servo motors, motion controllers, motion PLCs, I/O module etc.

Today, Leadshine is a publicly listed company(stock code002979)with over 1,000 employees and 4 manufacturing facilities in China. We are the largest stepper product manufactures in China, and serve 10,000+ OEM clients from 60+ countries and in tens of industries.



Leadshine Shenzhen Headquarter



Shanghai Intelligent Industry Park



Production base in Shenzhen

R&D

Led by Dr. Li, a PhD majored in robotics & servo controls from MIT, Leadshine has one of the strongest R&D teams in the motion control industry.

The team consists of more than 100 R&D engineers and all of them are highly educated with most of them carry PhD & Master degrees in controls, electrical & electronics engineering, mechanical engineering, mechatronics, computer engineering, and computer science.

Their strong background and experience allow Leadshine capable of designing superior quality products based the latest technology in the most efficient way.

Product Quality

Leadshine operates manufacturing facilities which are superiorly equipped, professionally staffed, and ISO-9001 certified.

That allows Leadshine to provide highly reliable quality motion control products OEM clients in the shortest time.

Leadshine's products have proven records of being successfully adopted in thousands of applications such as CNC routers, mills, plasmas, lathes, laser cutters/engravers/markers,

inkjet printers, plotters, electronics equipments, medical equipments, semiconductor assembly & inspection machines, electronics machines, packaging equipments, textile machines,

robotics, pick-and-place devices, etc. In most cases, Leadshine's standard "off-the-shelf" products are able to satisfy the motion control needs for most applications.

For many OEM applications with special requirements, Leadshine also offers customized products with optimized performance.

Support and Service

Leadshine believes the key to be a successful motion product supplier is the commitment to fully understanding our customer's applications and working closely with our OEM clients.

In many cases, Leadshine engineers can participate in the whole process of client product development, including initial application evaluation, product selection, design help & suggestion.

Our expertise and experience allow us to help OEM clients to produce competitive high quality machines in their industries.

Contents

Overview

Company Profile	01
Typical Industry Applications	03
Product Overview	04
Product Quick Selection	07

Stepper Products

Part Numbers	18
EM3E Series Fieldbus Stepper Drives	19
2EM3EIP Series Fieldbus Stepper Drives	21
EM2RS Series Fieldbus Stepper Drives	22
Pulse Control Stepper Drives	23
CM Series Stepper Motors	27

Closed Loop Stepper Products

Part Numbers	39
CS3E Series Fieldbus Closed Loop Stepper Drives	40
2CS3EIP Series Fieldbus Closed Loop Stepper Drives	42
CS2RS Series Fieldbus Closed Loop Stepper Drives	43
Pulse Control Closed Loop Stepper Drives	44
CS-M Series Closed Loop Stepper Motors	46

Integrated Stepper Motors

Integrated Stepper Motors	54
---------------------------	----

Other Products

LSP Series Power Supplies	58
PLF Series Gearboxes	59

Typical Industry Applications



ELECTRONIC MANUFACTURING EQUIPMENT

- Dispensing machine
- Screw locking machine
- SMT
- Wire stripping machine
- Battery industry



LASER MACHINE INDUSTRY

- Laser marking machine
- Laser cutting machine
- Jade carving machine
- Wood carving machine



SPECIAL MACHINE TOOL INDUSTRY

- CNC machine
- Die stamping machine



PACKAGING

- Food packaging equipment
- Beverage packaging equipment



TEXTILE AND GARMENT

- Computer cutting plotter
- Template cutting machine
- Garment proofing machine
- Pattern cutting machine
- Vertical jet cutting machine



MEDICAL AND HEALTHCARE INDUSTRY

- Biochemical analyzer
- Peristaltic pump
- Mask machine
- Blood sample analyzer
- Urine analyzer

Product Overview

Fieldbus Stepper Drives



EM3E Series EM2RS Series 2EM3EIP Series

Power Voltage:

- 20-50VDC, 20-80VDC
- 30-110VDC or 20-80VAC

Command Source:

- EtherCAT, EtherNet/IP, Modbus RTU

Inputs and Outputs:

- EM3E-522E/556E/870E: 5 digital inputs, 2 digital outputs
- EM3E-A882: 7 digital inputs, 6 digital outputs
- 2EM3E Series: Dual axis, 4 digital inputs, 2 digital outputs
- 2EM3EIP Series: 2-axis, 4 digital inputs, 2 digital outputs

Pulse Control Stepper Drives



EM Series DM Series

Power Voltage :

- 12-40VDC, 20-50VDC, 20-80VDC
- 30-110VDC or 20-80VAC, 110VAC±10%, 220VAC±10%

Command Source:

- EM-S: Pulse&Direction, CW&CCW
- DM-E: Pulse&Direction

Inputs and Outputs:

- DM332E/322E: 3 digital inputs
- DM542E/556E: 3 digital inputs, 1 digital output
- DMA860E: 3 digital inputs, 2 digital outputs
- DM1182/DM2282: 3 digital inputs
- 3DM580S/883/2283: 3 digital inputs
- EM-S: 3 digital inputs, 1 digital output

Standard Stepper Motors

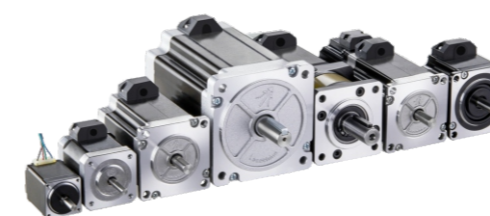

CM Series

Frame Size:

- From NEMA 08(20mm) to NEMA 51(130mm)
- 2-phase: 20mm, 28mm, 35mm, 42mm, 57mm, 60mm, 86mm, 110mm, 130mm
- 3-phase: 57mm, 86mm, 110mm

Options:

- Dual shaft
- Encoder
- Brake
- IP65 waterproof
- Gearbox

Fieldbus Closed Loop Stepper Drives



CS3E Series CS2RS Series CS3EIP Series

- Power Voltage:**
- 20-50VDC
 - 30-110VDC or 20-80VAC
- Command Source:**
- EtherCAT, EtherNet/IP, Modbus RTU
- Inputs and Outputs:**
- CS3E-D503/507/1008: 7 digital inputs/7 digital outputs
 - CS2RS-D503/507/1008: 7 digital inputs, 3 digital outputs
 - 2CS3E series: Dual axis, 4 digital inputs, 2 digital outputs
 - 2CS3EIP series: 2-axis, 4 digital inputs, 2 digital outputs

Integrated Stepper Motors



iEM Series: open loop
iCS Series: closed loop

iEM-RS Series
iCS-RS Series

- Power Voltage:**
- 20-36VDC
 - 20-50VDC
- Command Source:**
- iEM/iCS: Pulse&Direction
 - iEM-RS/iCS-RS: Modbus RS485
- Inputs and Outputs:**
- 3 digital inputs, 1 digital output

Pulse Control Closed Loop Stepper Drives



CS1 Series CS Series

- Power Voltage:**
- 20-50VDC
 - 20-72VDC
 - 20-80VAC or 30-110VDC
- Command Source:**
- Pulse&Direction, CW&CCW
- Inputs and Outputs:**
- CS1-D507S: 4 digital inputs, 3 digital outputs, encoder outputs
 - CS1-D728: 4 digital inputs, 3 digital outputs
 - CS-D507E: 3 digital inputs, 2 digital outputs
 - CS-D1008E: 3 digital inputs, 2 digital outputs

Power Supplies



LSP Series

- Power Supplies:**
- 220VAC±10% or 110VAC±10% input
 - 260W: 24VDC output
 - 360W: 24VDC/36VDC/48VDC output
 - 400W: 60VDC output

Closed Loop Stepper Motors



CS-M Series & ES2-MH Series

- Frame Size and Encoder:**
- 20mm: 1000 line
 - 28mm: 1000 line
 - 42mm: 1000/5000 line
 - 57mm: 1000/5000 line
 - 60mm: 1000/5000 line
 - 86mm: 1000/5000 line
 - 110mm: 1000/5000 line
- Options:**
- Brake
 - IP65 waterproof

Gearboxes

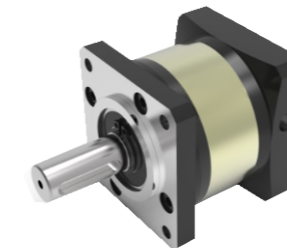

PLF Series

- Gearboxes:**
- 60mm: 3:1, 5:1, 7:1, 10:1
 - 90mm: 3:1, 5:1, 7:1, 10:1
 - NEMA 23 and 34
 - 1 to 2 stages
 - High precision
 - Low noise

Leadshine Stepper Systems Quick Selection

Stepper Motors

- Above matched drive is default Pulse & Direction type, other control types of drive also can be matched;
- 3-phase stepper motors still keep selling 3S series, others recommend CM series;
- Contact Leadshine for other customized model such as inch shaft diameters, modified cable, etc.





Phase/ Series	Frame Size	Length(mm)	Model	Rate Current (A)	Holding Torque(N.m)	Matched Drives	Remark	
2-Phase/ CM	NEMA 8	33	20CM003	0.6	0.03	EM415S		
		45	20CM005	0.6	0.05	EM415S		
	NEMA 11	32	28CM006	1.2	0.06	EM415S		
		41	28CM010	1.2	0.1	EM415S		
		51	28CM013	1.2	0.13	EM415S		
	NEMA 14	31	35CM015	2.0	0.15	EM422S		
		47	35CM04	2.0	0.4	EM422S		
	NEMA 17	33	42CM02-1A	1.0	0.2	EM415S		
			42CM02	1.5	0.2	EM422S		
		40	42CM04-1A	1.0	0.4	EM415S		
			42CM04	1.5	0.4	EM422S		
		47	42CM06-1A	1.5	0.6	EM422S		
			42CM06	2.5	0.6	EM422S/EM542S	Performance in high-speed	
			42CM06-SZ	2.5	0.6	EM422S/EM542S	Motor with dual shaft	
		60	42CM08-1A	1.5	0.8	EM422S		
			42CM08	2.5	0.8	EM422S/EM542S	Performance in high-speed	
			42CM08-SZ	2.5	0.8	EM422S/EM542S	Motor with dual shaft	
		NEMA 23	41	57CM06	3.0	0.6	EM542S	
			56	57CM13-3A	3.0	1.3	EM542S	
	57CM13			4.0	1.3	EM556S	Performance in high-speed	
	57CM13-SZ			4.0	1.3	EM556S	Motor with dual shaft	
	96		57CM13-BZ	4.0	1.3	EM556S	Motor with brake	
	65		57CM13-FS	4.0	1.3	EM556S	IP65 waterproof	
	76		57CM23-3A	3.0	2.3	EM542S		
			57CM23-4A	4.0	2.3	EM556S		
			57CM23	5.0	2.3	EM556S/EM870S	Performance in high-speed	
			57CM23-SZ	5.0	2.3	EM556S/EM870S	Motor with dual shaft	
	116		57CM23-BZ	5.0	2.3	EM556S/EM870S	Motor with brake	
	90		57CM23-FS	5.0	2.3	EM556S/EM870S	Motor with waterproof	
	84		57CM26-4A	4.0	2.6	EM556S		
			57CM26	5.0	2.6	EM556S/EM870S	Performance in high-speed	
			57CM26-SZ	5.0	2.6	EM556S/EM870S	Motor with dual shaft	
	67	D57CM21-4A	4.0	2.1	EM556S			
		D57CM21	5.0	2.1	EM556S/EM870S	Performance in high-speed		
		D57CM21-SZ	5.0	2.1	EM556S/EM870S	Motor with dual shaft		
	88	D57CM31-4A	4.0	3.1	EM556S			
		D57CM31	5.0	3.1	EM556S/EM870S	Performance in high-speed		
		D57CM31-SZ	5.0	3.1	EM556S/EM870S	Motor with dual shaft		

Phase/Series	Frame Size	Length(mm)	Model	Rate Current (A)	Holding Torque(N.m)	Matched Drives	Remark
2-Phase/ CM	NEMA 34	67	60CM22X	5.0	2.2	EM556S/EM870S	Motor with dual shaft
			60CM22X-SZ	5.0	2.2	EM556S/EM870S	Motor with brake
		110	60CM35X-FS	5.0	2.2	EM556S/EM870S	
		85	60CM30X	5.0	3.0	EM556S/EM870S	
			60CM30X-SZ	5.0	3.0	EM556S/EM870S	Motor with dual shaft
		124	60CM30X-BZ	5.0	3.0	EM556S/EM870S	Motor with brake
		65	86CM35	4.0	3.5	EM556S/EM870S	
		80	86CM45	6.0	4.5	EM882S	
			86CM45-SZ	6.0	4.5	EM882S	Motor with dual shaft
		114	86CM45-BZ	6.0	4.5	EM882S	Motor with brake
		90	86CM45-FS	6.0	4.5	EM882S	Motor with waterproof
		98	86CM80	6.0	8.0	EM882S	
		118	86CM85	6.0	8.5	EM882S	
			86CM85-SZ	6.0	8.5	EM882S	Motor with dual shaft
		152	86CM85-BZ	6.0	8.5	EM882S	Motor with brake
		130	86CM85-FS	6.0	8.5	EM882S	Motor with waterproof
		129	86CM120	6.0	12	EM882S/DM1182	
		NEMA 42/ NEMA 51	115	110CM12	6.0	12	DM2282
	150		110CM20	6.5	20	DM2282	
	201		110CM28	6.0	28	DM2282	
283	130HS45		7.0	45	DM2282		
3-Phase/ 3S	NEMA 23	50	573S09	3.5	0.9	3DM580S	
		76	573S15	5.8	1.5	3DM580S	
		80	573S20-LS	5.8	1.5	3DM580S	
	NEMA 34	71	863S22	5.0	2.2	3DM883	
		103	863S42	5.0	4.2	3DM883	
		135	863S68H	2.3	6.8	3DM2283	

Phase/Series	Frame Size	Length(mm)	Model	Rate Current (A)	Holding Torque(N.m)	Matched Drives	Remark	
2-Phase/ CM	NEMA 11	51	28CM013-ZK	1.2	0.13	EM415S	Hollow shaft	
		40	42CM04-ZK	2.5	0.4	EM422S	Hollow shaft	
	NEMA 17	79	42CM06-BZ	2.0	0.6	EM422S	Brake	
		88	42CM06-RD05	2.5	0.6	EM422S/EM542S	Gearbox	
		88	42CM06-RD10	2.5	-	EM422S/EM542S	Gearbox	
		95	42CM06-RD20	2.5	-	EM422S/EM542S	Gearbox	
		92	42CM08-BZ	2.0	0.8	EM422S/EM542S	Brake	
		101	42CM08-RD05	2.5	-	EM422S/EM542S	Gearbox	
		101	42CM08-RD10	2.5	-	EM422S/EM542S	Gearbox	
		108	42CM08-RD20	2.5	-	EM422S/EM542S	Gearbox	
		60	42CM08-SZ-ZK	2.5	0.8	EM422S/EM542S	Hollow shaft	
		NEMA 23	55	57CM12C-3A-CZ	3.0	1.2	EM542S	Plug-in terminals
			55	57CM12C-ZK	4.0	1.2	EM542S/EM556S	Hollow shaft
			110	57CM12C-RD05	4.0	-	EM542S/EM556S	Gearbox
			110	57CM12C-RD10	4.0	-	EM542S/EM556S	Gearbox
	76		57CM22C-4A-16-CZ	4.0	2.2	EM556S	Plug-in terminals	
	131		57CM22C-RD05	5.0	-	EM556S	Gearbox	
	131		57CM22C-RD10	5.0	-	EM556S	Gearbox	
	NEMA 34	98	86CM80-ZK	6.0	8.0	EM556S	Hollow shaft	

Stepper Drives

☑ : Support ☐ : Not Support

Series	Picture	Model	Matched Motor Series	Command Source					Electrical Parameters				Motion Function Features					I/O		Others		
				EtherCAT	RS485 Modbus	Pul&Dir	CW&CCW	Others	Power Voltage	Output Current	Logical Voltage		Alarm Output	Brake Output	Self Test	Anti-resonance	Auto-tuning Disable	Digital Input	Digital Output	Mechanical Size (mm)	Tuning Cable	Tuning Software
EM3E		EM3E-522E		☑					20-50VDC	0.3-2.2A	12-24V		☑	☑	☑	☑	☑	6	2	118*90*34	CABLE-MUSB1M5	Leadshine MotionStudio
		EM3E-556E		☑					20-50VDC	2.1-5.6A	12-24V		☑	☑	☑	☑	☑	6	2	118*90*34		
		EM3E-870E		☑					20-80VDC	2.1-7.0A	12-24V		☑	☑	☑	☑	☑	6	2	118*90*34		
		EM3E-A882		☑					18-80VAC 30-110VDC	2.1-8.2A	12-24V		☑	☑		☑	☑	7	7	151*113*40	Standard ProTuner	
EM2RS		EM2RS-522			☑				20-50VDC	0.3-2.2A	12-24V		☑	☑		☑	☑	7	3	118*79.5*25.5	CABLE-PC-1	Leadshine MotionStudio
		EM2RS-556			☑				20-50VDC	0.5-5.6A	12-24V		☑	☑		☑	☑	7	3	118*79.5*25.5		
		EM2RS-870			☑				20-80VDC	0.5-7.0A	12-24V		☑	☑		☑	☑	7	3	118*79.5*25.5		
		EM2RS-A882			☑				18-80VAC 30-110VDC	0.5-8.2A	12-24V		☑	☑		☑	☑	7	3	151*97*53		
EM-S		EM415S(V2.0)	CM Series			☑	☑		12-40VDC	0.3-1.5A	5V		☑		☑	☑	3	1	86*55*20	CABLE-PC-1	Standard ProTuner	
		EM422S(V2.0)				☑	☑		12-40VDC	0.3-2.2A	5V		☑		☑	☑	3	1	86*55*20			
		EM532MINI				☑			18-50VDC	0.3-3.2A	5V		☑		☑		3	1	62*50*26			
		EM542S(V3.0)				☑	☑		20-50VDC	0.5-4.2A	5 / 24V		☑	☑	☑	☑	3	2	118*75.5*25.5			
		EM556S(V3.0)				☑	☑		20-50VDC	0.5-5.6A	5 / 24V		☑	☑	☑	☑	3	2	118*75.5*34			
		EM870S(V3.0)				☑	☑		20-80VDC	0.5-7.0A	5 / 24V		☑	☑	☑	☑	3	2	118*75.5*34			
		EM882S				☑	☑		20-80VDC	0.5-8.2A	5V		☑			☑	☑	3	1	151*97*48	CABLE-PC	
DM-E		DM322E				☑			12-30VDC	0.3-2.2A	5V				☑		3	0	86*55*20	/		
		DM332E				☑			12-30VDC	1.0-3.2A	5V				☑		3	0	86*55*20	/		
		DM542E(V3.0)				☑			20-50VDC	1.0-4.2A	5 / 24V		☑		☑		3	0	118*75.5*25.5	CABLE-PC-1	Standard ProTuner	
		DM556E(V3.0)				☑			20-50VDC	1.7-5.6A	5 / 24V		☑		☑		3	0	118*75.5*34	CABLE-PC-1	Standard ProTuner	
		DM860E				☑	☑		20-80VDC	2.4-7.2A	5V				☑		3	0	151*97*42.5	/		
		DMA860E(V3.0)				☑	☑		18-80VAC 30-110VDC	2.4-7.2A	5 / 24V		☑	☑		☑	☑	3	2	151*97*57	CABLE-PC-1	Standard ProTuner
DM (AC input / 3 phase)		DMA860H	HS&CM Series			☑	☑		18-80VAC 30-110VDC	2.4-7.2A	5V				☑	☑	3	0	151*97*53	/		
		DMA882S				☑	☑		18-80VAC 30-110VDC	0.5-8.2A	5V		☑		☑	☑	3	1	151*97*53	CABLE-PC	Standard ProTuner	
		DM1182				☑	☑		70-130VAC	0.5-8.2A	5V		☑		☑	☑	3	1	200*145*83		CABLE-PC	DMSeries ProTuner
		DM2282				☑	☑		180-240VAC	0.5-8.2A	5V		☑		☑	☑	3	1	200*145*83			
		3DM580S		3S Series			☑	☑		20-50VDC	0.5-8.0A	5 / 24V		☑	☑	☑	☑	3	1	118*75.5*34	CABLE-PC-1	Standard ProTuner
		3DM883					☑	☑		20-80VDC	2.2-8.3A	5 / 24V		☑	☑	☑	☑	3	2	151*97*57		
3DM2283			☑		☑		180-240VAC	2.2-11.7A	5V		☑		☑	☑	3	1	200*145*83	CABLE-PC	DMSeries ProTuner			

■ Closed Loop Stepper Motors

1. Below matched drives are Pulse Control type, EtherCAT and Modbus RS485 types are also available;
2. 3-phase high voltage closed loop stepper motors are ES2-MH series, others are CS-M series;
3. Maximum speed up to 3000 rpm, but depends on power voltage, current and load.



Phase/Series	Frame Size	Length(mm)	Model	Holding Torque(N.m)	Matching Drives	Remark	
2-phase/ CS-M	NEMA 17	56	CS-M21702	0.2	CS-D507E/CS1-D507S		
		63	CS-M21704	0.4	CS-D507E/CS1-D507S	This motor is not recommended	
		70	CS-M21706	0.6	CS-D507E/CS1-D507S		
		83	CS-M21708	0.8	CS-D507E/CS1-D507S		
	NEMA 23	60	CS-M22306	0.6	CS-D507E/CS1-D507S		
		75	CS-M22313	1.3	CS-D507E/CS1-D507S	Replace ES-M22310	
		109	CS-M22313B	1.3	CS-D507E/CS1-D507S	Motor with brake	
		94	CS-M22313WP	1.3	CS-D507E/CS1-D507S	Motor with waterproof	
		95	CS-M22323	2.3	CS-D507E/CS1-D507S	Replace ES-M22320	
		131	CS-M22323B	2.3	CS-D507E/CS1-D507S	Motor with brake	
		115	CS-M22323WP	2.3	CS-D507E/CS1-D507S	Motor with waterproof	
		103	CS-M22326	2.6	CS-D507E/CS1-D507S		
		86	CS-M22321-L	2.1	CS-D507E/CS1-D507S	NEMA23 motor with large body	
		105	CS-M22331-L	3.1	CS-D507E/CS1-D507S	NEMA23 motor with large body	
		NEMA 24	89	CS-M22422	2.2	CS-D507E/CS1-D507S	
			129	CS-M22422B	2.2	CS-D507E/CS1-D507S	Motor with brake
	113		CS-M22422WP	2.2	CS-D507E/CS1-D507S	Motor with waterproof	
	107		CS-M22430	3.0	CS-D507E/CS1-D507S		
	143		CS-M22430B	3.0	CS-D507E/CS1-D507S	Motor with brake	
	130		CS-M22430WP	3.0	CS-D507E/CS1-D507S	Motor with waterproof	
	NEMA 34	95	CS-M23435	3.5	CS-D1008E		
		109	CS-M23445	4.5	CS-D1008E		
		144	CS-M23445B	4.5	CS-D1008E	Motor with brake	
		115	CS-M23445WP	4.5	CS-D1008E	Motor with waterproof	
		127	CS-M23480	8.0	CS-D1008E		
		152	CS-M23480B	8.0	CS-D1008E	Motor with brake	
		133	CS-M23480WP	8.0	CS-D1008E	Motor with waterproof	
		147	CS-M23485	8.5	CS-D1008E		
		182	CS-M23485B	8.5	CS-D1008E	Motor with brake	
		153	CS-M23485WP	8.5	CS-D1008E	Motor with waterproof	
		158	CS-M234120	12	CS-D1008E		
		193	CS-M234120B	12	CS-D1008E	Motor with brake	
	164	CS-M234120WP	12	CS-D1008E	Motor with waterproof		
	3-phase/ ES2-MH	NEMA 34	157	ES2-MH33480	8.0	ES-DH2306	
190			ES2-MH33480B	8.0	ES-DH2306	Motor with brake	
162			ES2-MH33480WP	8.0	ES-DH2306	Motor with waterproof	
184			ES2-MH334100	10	ES-DH2306		
218			ES2-MH334100B	10	ES-DH2306	Motor with brake	
191			ES2-MH334100WP	10	ES-DH2306	Motor with waterproof	
NEMA 42		162	ES2-MH342120	12	ES-DH2306		
		207	ES2-MH342120B	12	ES-DH2306	Motor with brake	
	167	ES2-MH342120WP	12	ES-DH2306	Motor with waterproof		
	244	ES2-MH342200	20	ES-DH2306			

Note: Contact Leadshine for Gearboxes and Encoder information.

Phase/Series	Frame Size	Length(mm)	Model	Holding Torque(N.m)	Matching Drives	Remark
2-phase/CS-M	NEMA 8	51	CS-M208003	0.03	CS-D507E	-
	NEMA 11	62	CS-M211013	0.13	CS-D507E	-
	NEMA 17	93	CS-M21704B	0.4	CS-D507E	Brake
		101	CS-M21706B	0.6	CS-D507E	Brake
		113	CS-M21708B	0.8	CS-D507E	Brake
	NEMA 23	96	CS-M22323-S	2.3	CS-D507E	1/4-inch shaft diameter
		96	CS-M22323-E5Z	2.3	CS-D507E	5000-line
		104	CS-M22326-S	2.6	CS-D507E	1/4-inch shaft diameter
		105	CS-M22331-L-S	3.1	CS-D507E	3/8-inch shaft diameter
	NEMA 24	107	CS-M22430-I14	3.0	CS-D507E	AC servo flange
		147	CS-M22430B-I14	3.0	CS-D507E	AC servo flange, Brake
		107	CS-M22430-E5Z	3.0	CS-D507E	5000-line
		143	CS-M22430B-E5Z	3.0	CS-D507E	Brake, 5000-line
	NEMA 34	109	CS-M22445-S	4.5	CS-D1008E	1/2-inch shaft diameter
		109	CS-M22445-E5Z	4.5	CS-D1008E	5000-line
		135	CS-M22445B-E5Z	4.5	CS-D1008E	Brake, 5000-line
		127	CS-M23480-S	8.0	CS-D1008E	1/2-inch shaft diameter
		127	CS-M23480-E5Z	8.0	CS-D1008E	5000-line
		147	CS-M23485-S	8.5	CS-D1008E	1/2-inch shaft diameter
		147	CS-M23485-E5Z	8.5	CS-D1008E	5000-line
		172	CS-M23485B-E5Z	8.5	CS-D1008E	Brake, 5000-line
		158	CS-M234120-E5Z	12	CS-D1008E	5000-line
		184	CS-M234120B-E5Z	12	CS-D1008E	Brake, 5000-line











Closed Loop Stepper Drives

☑ : Support ☐ : Not Support

Series	Picture	Model	Matched Motor Series	Command Source				Electrical Parameters			Motion Function Features						I/O		Encoder Resolution(ppr)	Others					
				EtherCAT	RS485 Modbus	Pul&Dir	CW&CCW	Power Voltage	Output Current	Logical Voltage	Alarm Output	Brake Output	Self Test	Fault Reset	Z Signal	Open/Closed Loop Selection	Digital Input	Digital Output		Mechanical Size (mm)	Tuning Cable	Tuning Software			
CS3E		CS3E-D503	CS-M	☑				20-50VDC	0.3-3.0A	5-24V			☑	☑		☑	☑	☑	7	7	1000/5000	130*90.4*34	CABLE-MUSB1M5	Leadshine MotionStudio	
		CS3E-D507		☑				20-50VDC	0.5-7.0A	5-24V			☑	☑		☑	☑	☑	7	7	1000/5000	130*90.4*34			
		CS3E-D1008		☑				18-80VAC 30-110VDC	0.5-8.0A	12-24V			☑	☑		☑	☑	☑	7	7	1000/5000	151*113*40			
		CS3E-D503E		☑				20-50VDC	0.3-3.0A	12-24V			☑	☑	☑	☑	☑	☑	6	2	1000/5000	118*90*34			
		CS3E-D507E		☑				20-50VDC	0.5-7.0A	12-24V			☑	☑	☑	☑	☑	☑	6	2	1000/5000	118*90*34			
CS2RS		CS2RS-D503			☑				20-50VDC	0.3-3.0A	12-24V			☑	☑		☑	☑	☑	7	3	1000/5000	118*79.5*25.5		CABLE-PC-1
		CS2RS-D507			☑				20-50VDC	0.5-7.0A	12-24V			☑	☑		☑	☑	☑	7	3	1000/5000	118*79.5*25.5		
		CS2RS-D1008			☑				18-80VAC 30-110VDC	0.5-8.0A	12-24V			☑	☑		☑	☑	☑	7	3	1000/5000	151*97*53		
CS1		CS1-D507S				☑	☑		20-50VDC	0.5-7.0A	5 / 24V			☑	☑	☑	☑	☑	☑	4	6	1000/5000	118*79.5*25.5		CABLE-PC-1
		CS1-D728				☑	☑		20-72VDC	0.5-8.0A	5 / 24V			☑	☑	☑	☑	☑	☑	4	6	1000/5000	118*79.5*25.5		
CS		CS-D403				☑	☑		20-50VDC	0.3-3.0A	5V			☑	☑		☑	☑	3	1	1000/5000	116*69.2*26.5	CABLE-PC		ProTuner CS_V3.0
		CS-D508				☑	☑		20-50VDC	0.5-7.0A	5V			☑	☑		☑	☑	3	1	1000/5000	116*69.2*26.5			
		CS-D808				☑	☑		20-80VDC	0.5-8.0A	5V			☑	☑		☑	☑	3	1	1000/5000	151*97*53			
		CS-D1008				☑	☑		18-80VAC 30-110VDC	0.5-8.0A	5V			☑	☑		☑	☑	3	1	1000/5000	151*97*53			
		CS-D507E				☑	☑		20-50VDC	0.5-7.0A	5 / 24V			☑	☑		☑	☑	3	2	1000/5000	116*69.2*26.5	CABLE-PC-1		
		CS-D1008E			☑	☑		18-80VAC 30-110VDC	0.5-8.0A	5 / 24V			☑	☑		☑	☑	3	2	1000/5000	151*97*53				

Integrated Stepper Motors

☑ : Support ☐ : Not Support

Series	Picture	Model	Frame Size	Motor Type	Length (mm)	Holding Torque (mm)	Control Type					Electrical Parameters			Motion Function Features			I/O		Tuning Cable	Tuning Software	
							RS485 Modbus	Pulse&Dir	CW&CCW			Power Voltage (VDC)	Output Current	Logical Voltage	Alarm Output	PR Mode	I/O Configurable	Digital input	Digital output			
iEM		iEM-1703	NEMA17	Open Loop	64	0.3		☑				20-36	0.3-3.0	5V	☑			3	1	CABLE-PC-1	Leadshine MotionStudio	
		iEM-1706			72	0.6		☑			20-36	0.3-3.0	5V	☑			3	1				
		iEM-1708			85	0.8		☑			20-36	0.3-3.0	5V	☑			3	1				
		iEM-RS1706			73	0.6	☑				20-36	0.3-3.0	12-24V	☑	☑			3	1			
		iEM-RS1708			86	0.8	☑				20-36	0.3-3.0	12-24V	☑	☑			3	1			
		iEM-2313	NEMA23		75	1.3		☑	☑		20-50	0.5-6.0	5V	☑					3			1
		iEM-2323			96	2.3		☑	☑		20-50	0.5-7.0	5V	☑					3			1
		iEM-2321-L			89	2.1		☑	☑		20-50	0.5-7.0	5V	☑					3			1
		iEM-2331-L			109	3.1		☑	☑		20-50	0.5-7.0	5V	☑					3			1
		iEM-RS2313			78	1.3	☑				20-50	0.5-6.0	12-24V	☑	☑				3			1
		iEM-RS2323			99	2.3	☑				20-50	0.5-7.0	12-24V	☑	☑				3			1
		iEM-2430	NEMA24		109	3.0		☑	☑		20-50	0.5-7.0	5V	☑					3			1
iEM-2435		122		3.5		☑	☑		20-50	0.5-7.0	5V	☑					3	1				
iCS		iCS-1703	NEMA17	Closed Loop (14-bit magnetic encoder)	64	0.3		☑				20-36	0.3-3.0	5V	☑		☑	3	1			
		iCS-1706			72	0.6		☑			20-36	0.3-3.0	5V	☑		☑	3	1				
		iCS-1708			85	0.8		☑			20-36	0.3-3.0	5V	☑		☑	3	1				
		iCS-RS1706			73	0.6	☑				20-36	0.3-3.0	12-24V	☑	☑	☑		3	1			
		iCS-RS1708			86	0.8	☑				20-36	0.3-3.0	12-24V	☑	☑	☑		3	1			
		iCS-2313	NEMA23		75	1.3		☑	☑		20-50	0.5-6.0	5V	☑		☑			3	1		
		iCS-2323			96	2.3		☑	☑		20-50	0.5-7.0	5V	☑		☑			3	1		
		iCS-2321-L			89	2.1		☑	☑		20-50	0.5-7.0	5V	☑		☑			3	1		
		iCS-2331-L			109	3.1		☑	☑		20-50	0.5-7.0	5V	☑		☑			3	1		
		iCS-RS2313			78	1.3	☑				20-50	0.5-6.0	12-24V	☑	☑	☑			3	1		
		iCS-RS2323			99	2.3	☑				20-50	0.5-7.0	12-24V	☑	☑	☑			3	1		
		iCS-2430	NEMA24		109	3.0		☑	☑		20-50	0.5-7.0	5V	☑		☑			3	1		
iCS-2435		122		3.5		☑	☑		20-50	0.5-7.0	5V	☑		☑			3	1				



Why Leadshine



Over 30,000,000 installed stepper & servo axes worldwide since 1997

Stepper Products

Stepper Drive Part Numbers

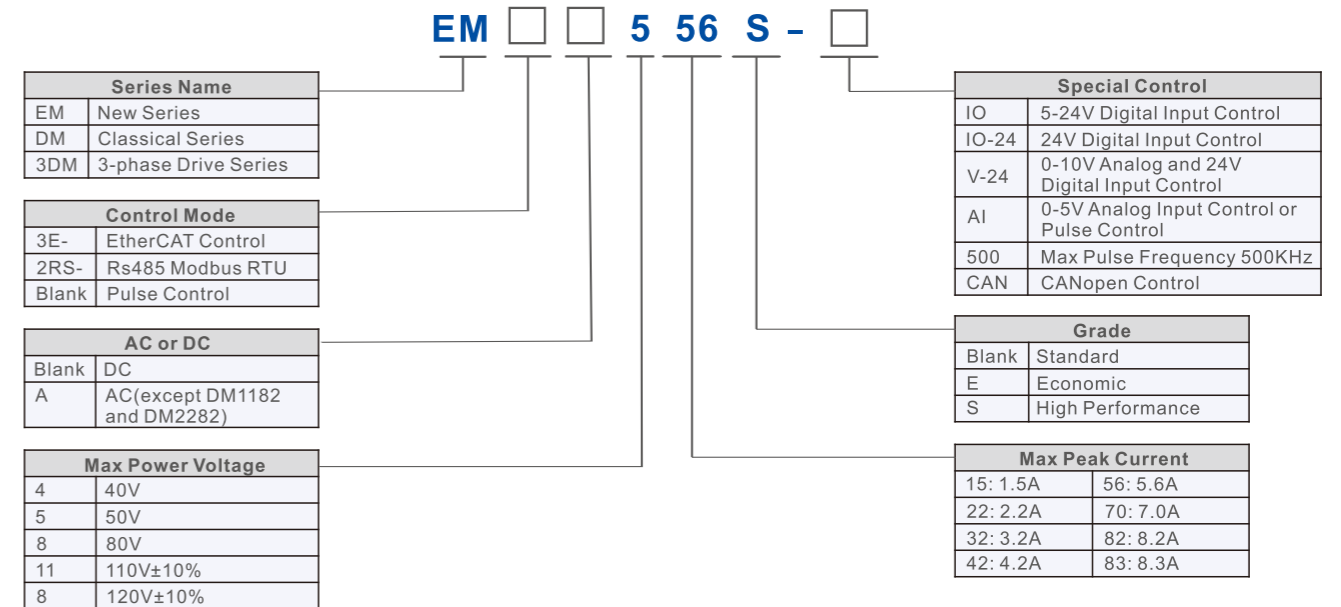

CM Series Stepper Motors

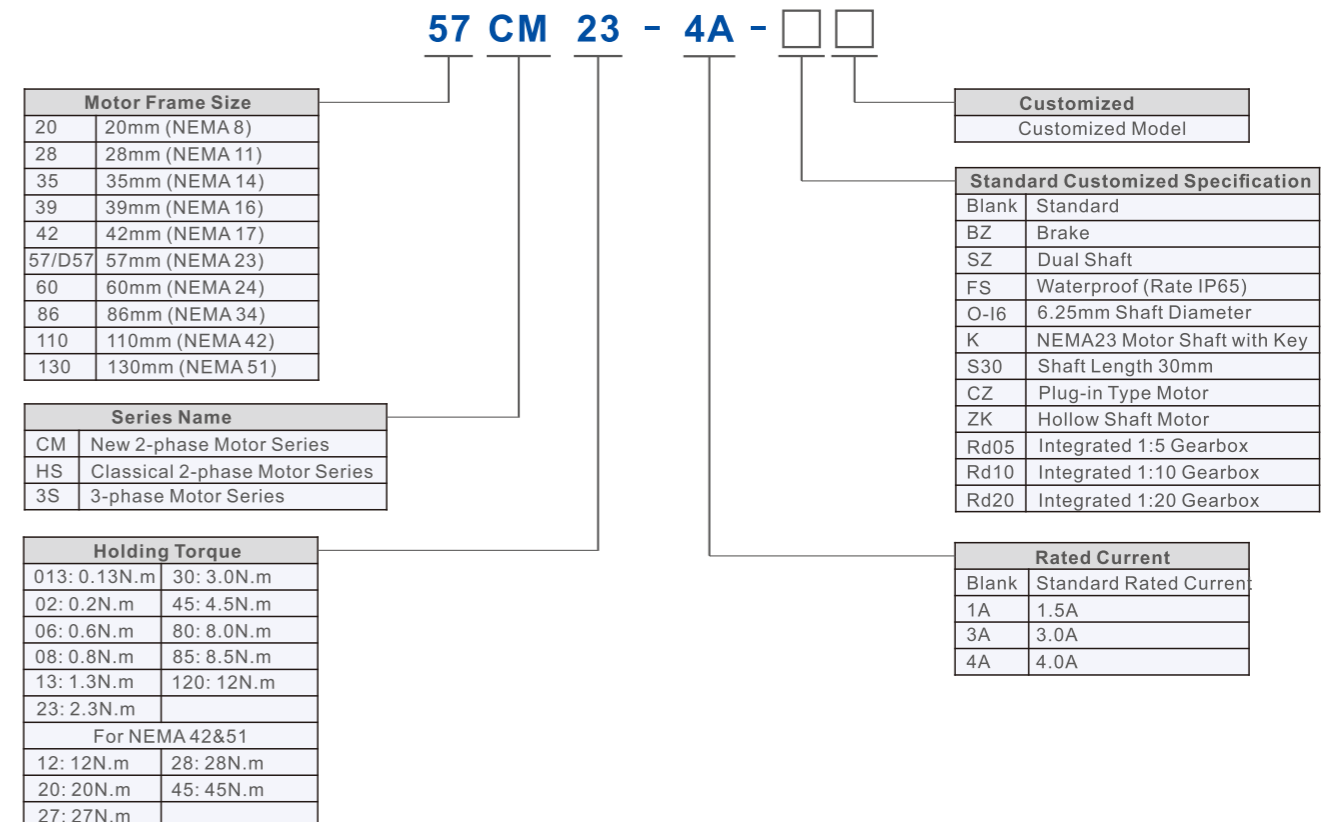

Fieldbus Stepper Drives

EM3E Series

- Support CoE control and CiA 402 protocol
- Matching most of master controller
- Conformance tested by ETG



Introduction

EM3E series drives support operating modes: Profile Position (PP), Profile Velocity (PV), Homing(HM), Cyclic Synchronous Position (CSP). The products can be matched with most of EtherCAT controller/PLC such as Beckhoff, Omron, Trio, etc.

Features

- Low noise and vibration, smooth motion
- EM3E support standard EtherCAT with operation modes of PP, PV, CSP, HM
- Configurable I/O features: limit switch, alarm, brake, etc
- Optically coupled isolated input, strong anti-interference ability
- Auto-tuning of motor parameters
- Protections for over voltage, over current etc.

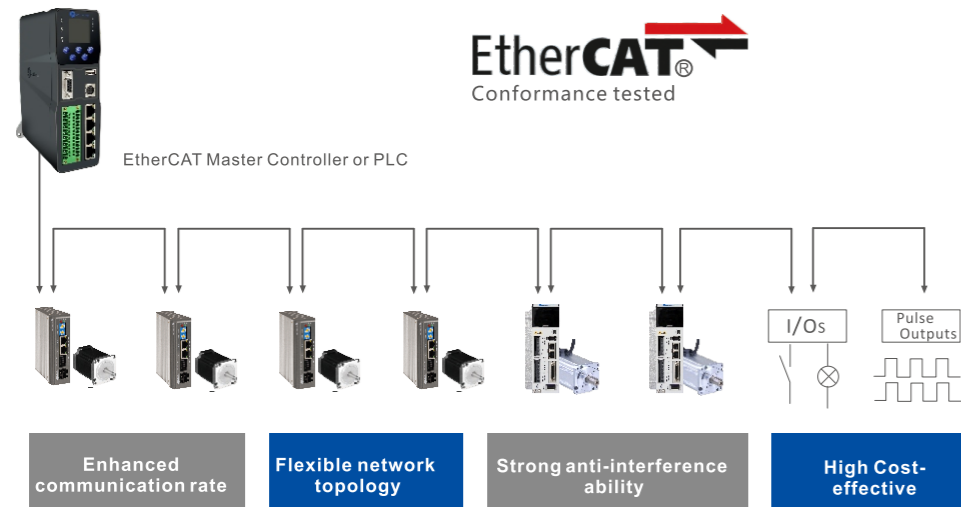

Models	Operating Voltage	Output Current(A)	Matching Motor	Weight(g)	Dimension(mm)
EM3E-522E	20-50VDC	0.3-2.2	NEMA8/11/14/17	0.57	118*90.4*34
EM3E-556E	20-50VDC	2.1-5.6	NEMA17/23/24	0.57	118*90.4*34
EM3E-870E	20-80VDC	2.1-7.0	NEMA23/24/34	0.57	118*90.4*34
EM3E-A882	20-80VAC or 30-100VDC	2.1-8.0	NEMA34	0.85	151*113*20
CABLE-MUSB1M5	Tuning Cable				
CABLE-TX*M*-BUS	Network Cable: 0.1m, 0.2m, 0.3m, 0.4m, 1m, 1.5m, 2m, 3m,5m,7m, 10m,15m, 20m				

2EM3E Series



Dual axis control

- Only occupy the same network node
- The two axes can be controlled independently

Reduce installation space significantly

- Thinner than single shaft drives
- With the same number of axes, only half of the installation space is required

Reduce wire consumption

- Reduce the usage of network communication cables
- Reduce the usage of power cables

Product application is safe and secure

- EtherCAT bus effectively suppresses interference and clutter
- Enhanced version supports dual channel STO

Improve operation convenience significantly

- Spring terminal, plug and play, without IO wire
- MINI USB debugging interface, more convenient for parameter debugging
- Two sets of dip switches for site address setting, faster and more intuitive

Higher quality assurance

- The digital tube displays the node address, alarm diagnosis, and running status
- CE certification

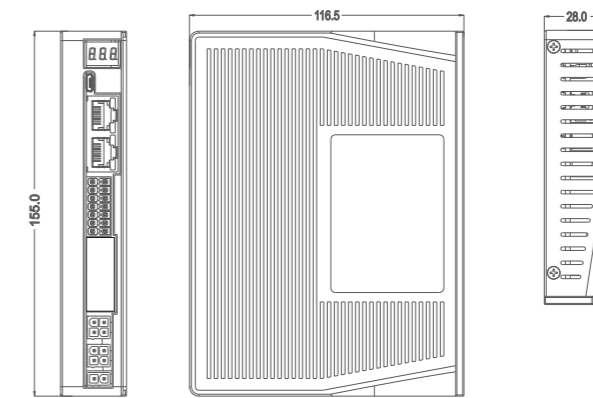

Models	Operating Voltage	Output Current(A)	Matching Motor	Weight(kg)	Dimension(mm)
2EM3E-522	20-50VDC	0.5-2.2	NEMA8/11/14/17	0.4	155*116.5*28
2EM3E-556	20-50VDC	1.0-5.6	NEMA17/23/24	0.4	155*116.5*28
2EM3E-870	20-80VDC	1.0-7.0	NEMA23/24/34	0.4	155*116.5*28
Termination Resistor	The last node needs to add the terminal resistance generally				
CABLE-USB1M5	Tuning cable				
CABLE-TX*M*-BUS	Network Cable: 0.1m, 0.2m, 0.3m, 0.4m, 1m, 1.5m, 2m, 3m,5m,7m, 10m,15m, 20m				

Fieldbus Stepper Drives

2EM3EIP Series

- Support EtherNet/IP fieldbus
- Matching most of master controller



Dual axis control

- Only occupy the same network node
- The two axes can be controlled independently

Reduce installation space significantly

- Thinner than single shaft drives
- With the same number of axes, only half of the installation space is required

Reduce wire consumption

- Reduce the usage of network communication cables
- Reduce the usage of power cables

Product application is safe and secure

- EtherNET/IP communication effectively suppresses interference and clutter
- Enhanced version supports dual channel STO

Improve operation convenience significantly

- Spring terminal, plug and play, without IO wire
- MINI USB debugging interface, more convenient for parameter debugging
- Two sets of dip switches for site address setting, faster and more intuitive

Higher quality assurance

- The digital tube displays the node address, alarm diagnosis, and running status
- CE certification

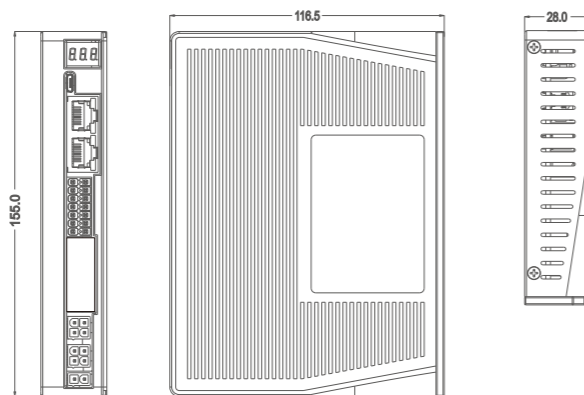

(Unit : mm)

Models	Operating Voltage	Output Current(A)	Matching Motor	Weight(kg)	Dimension(mm)
2EM3EIP-522	20-50VDC	0.5-2.2	NEMA8/11/14/17	0.4	155*116.5*28
2EM3EIP-556	20-50VDC	1.0-5.6	NEMA17/23/24	0.4	155*116.5*28
2EM3EIP-870	20-80VDC	1.0-7.0	NEMA23/24/34	0.4	155*116.5*28
Termination Resistor	The last node needs to add the terminal resistance generally				
CABLE-USB1M5	Tuning cable				
CABLE-TX*M*-BUS	Network Cable: 0.1m, 0.2m, 0.3m, 0.4m, 1m, 1.5m, 2m, 3m,5m,7m, 10m,15m, 20m				

Fieldbus Stepper Drives

EM2RS Series

- Standard Isolated RS485 Modbus
- Smooth motion & Anti-resonance
- Built-in Uni-axial Control Instruction
- HMI, PLC or External I/O start motion



Features

- ▶ 7 Programmable Inputs
 - Limit + / - or Origin inputs
 - Quick stop, Alarm reset and Enable inputs
 - JOG + / - or Position Table inputs
- ▶ 3 Programmable Outputs
 - Alarm, Brake outputs
 - Homing / Instruction / Path complete
- ▶ Modes of Operation
 - Velocity
 - Position
 - Homing
- ▶ Support Functions
 - Teaching
 - Interrupt
 - Skip, Suspend, Circulate motion
- ▶ PC Software for Easy Setup, Fine Tune
- ▶ Matching Motors:
 - NEMA8, 11,17, 23, 24, 34
 - Standard, dual shaft, brake, waterproof

2. Instruction smoothing

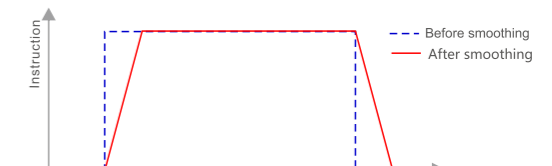

Figure A: When the controller sends a step signal of instruction, the stepper drive automatically smooth to a trapezoidal signal.

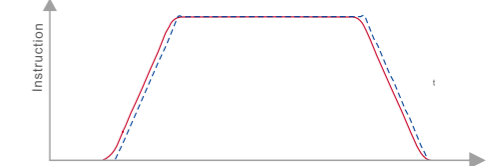
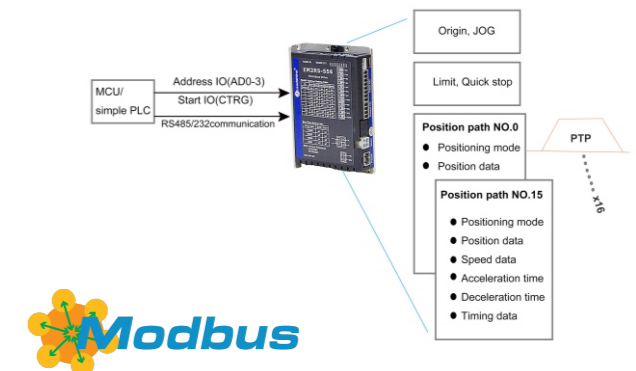
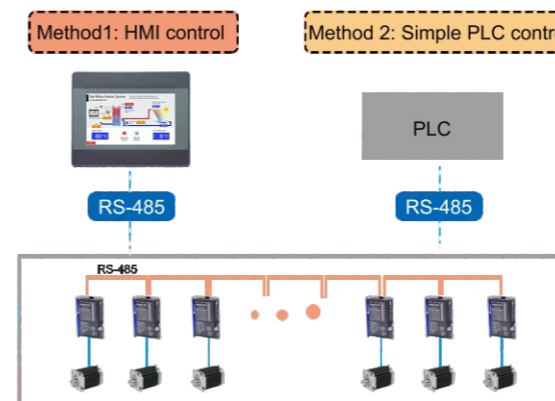

Figure B: When the controller sends a trapezoidal signal of instruction, the stepper drive automatically smooth to a s-shaped signal.

3. Built-in uni-axial control instruction

Programmable 16-segment position table, support positioning/homing/ limit/ quick stop/ JOG...

1. Support RS485 communication



Models	Operating Voltage	Output Current(A)	Matching Motor	Weight(kg)	Dimension(mm)
EM2RS-522	20-50VDC	0.3-2.2	NEMA8/11/14/17	0.55	118*79.5*25.5
EM2RS-556	20-50VDC	0.5-5.6	NEMA17/23/24	0.55	118*79.5*25.5
EM2RS-870	20-80VDC	0.5-7.0	NEMA23/24/34	0.55	118*79.5*25.5
EM2RS-A882	20-80VAC or 30-100VDC	0.5-8.0	NEMA24/34	0.57	151*97*53
CABLE-PC-1	Tuning Cable				
CABLE-TX*M*-BUS	Network Cable: 0.1m, 0.2m, 0.3m, 0.4m, 1m, 1.5m, 2m, 3m,5m,7m, 10m,15m, 20m				

Pulse Control Stepper Drives

- EM-S---Enhanced Version
- DM-E---Cost-effective Version



EM-S Series---Enhanced Performance

EM-S series stepper drives from Leadshine offer superior performance and exceptional high reliability. Based on Leadshine's 20+ years' experience in stepper motor control, they adopt the latest control technology and are ideal for modern machine manufactures. Not only inheriting features of smooth motion, low noise, low heating, etc. from past Leadshine stepper drives, they also offer new functions and features such as improved torque in all speed ranges, fault output, brake control, pulse command smoothing... They are capable of power wide range of stepper motors of NEMA 8, 11, 15, 17, 23, 34, and 42.

Features

- ▶ Torque increased by 10%-25%
- ▶ Step & DIR or CW & CCW control
- ▶ Alarm and Brake outputs
- ▶ 200kHz (500kHz optional) max frequency
- ▶ 5V or 24V signal voltage optional
- ▶ Soft-start with no "jump"
- ▶ Over-voltage, over-current

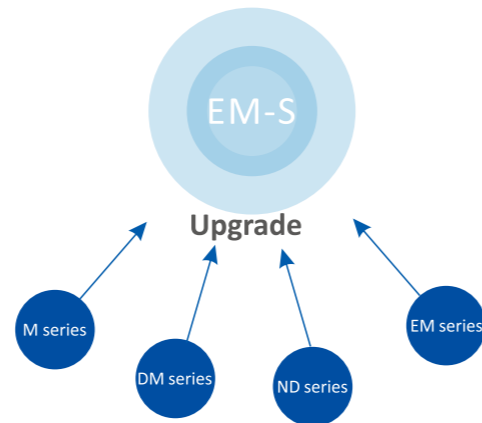

Torque comparison (same condition)

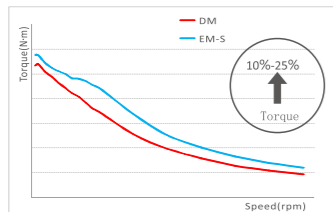

Features of Second DIP Switch

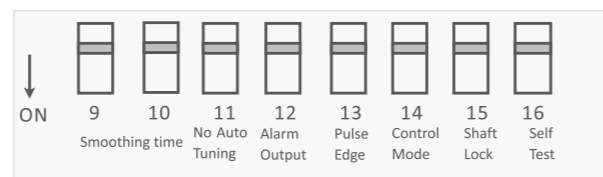

Pulse Smoothing Filter

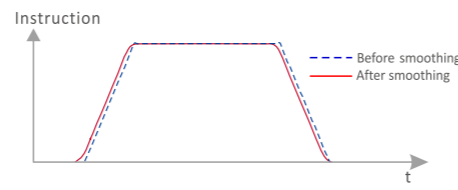
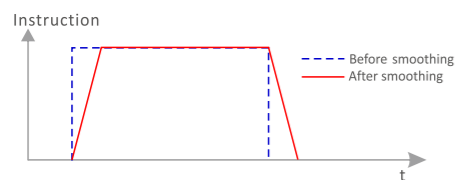

Alarm and Brake Outputs

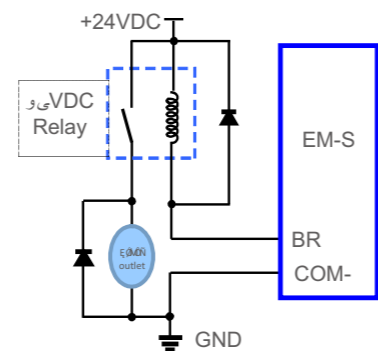
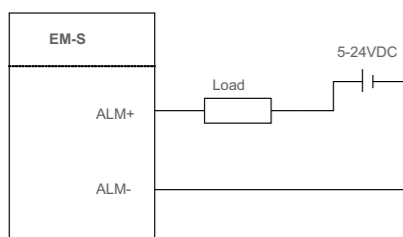

EM-S Series Electrical Specifications

Items	EM415S		EM422S		EM542S		EM556S		EM870S		EM882S	
	Min	Max	Min	Max	Min	Max	Min	Max	Min	Max	Min	Max
Output Current (A)	0.3	1.5	0.3	22	0.5	4.2	0.5	4.2	0.5	7.0	0.5	8.2
Power Voltage (VDC)	12	40	12	40	20	50	20	50	20	80	20	80
Max Input Frequency (kHz)	-	70	-	70	-	200	-	200 or 500*	-	200	-	200 or 500*
Logical Current (mA)	7	16	7	16	7	16	7	16	7	16	7	16
Logical Voltage (VDC)	0	5	0	5	0	5 or 24	0	5 or 24	0	5 or 24	0	5
Min Pulse Width (us)	7.5		7.5		2.5		2.5 or 1		2.5		2.5 or 1	
Matched Motors Size	NEMA8/11/14/17		NEMA17		NEMA17/23		NEMA23/24		NEMA23/24/34		NEMA34	

Note: (*) The drive with 500KHz is another model.

EM-S Series Interface and Dimensions

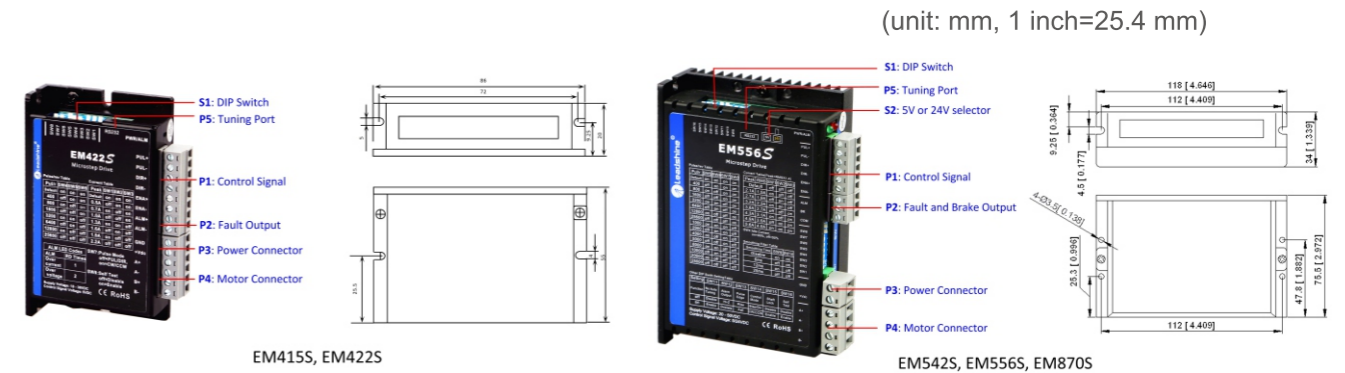

DM-E Series----Cost-effective

The DM-E series consists of stepper drives adopting Leadshine latest advanced stepper control technology. Those stepper drives are highly reliable with good performance and highly competitive cost. They can power a wide range of stepper motors from NEMA 8 to NEMA 34 (model dependent). DM-E stepper drives are easy to configure and setup. Output current and micro step resolution can be simply set up via DIP switches.



DM322E	DM332E	DM542E	DM556E	DMA860E
12-30 VDC	12-30 VDC	20-50 VDC	20-50 VDC	20-80 VAC/ 30-110 VDC
0.3-2.2 A	1.0-3.2 A	1.0-4.2 A	1.7-5.6 A	2.4-7.2 A

■ Dimensions

(unit: mm, 1 inch=25.4 mm)

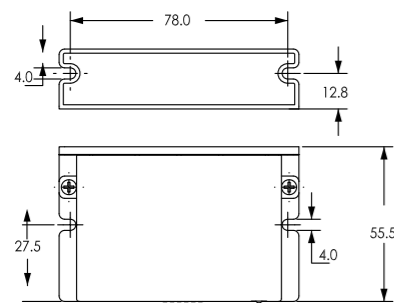

DM322E / DM332E

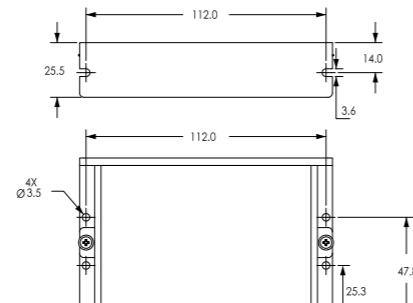

DM542E

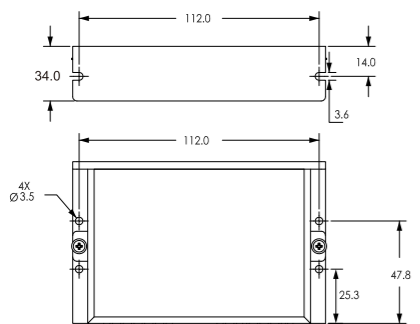

DM556E

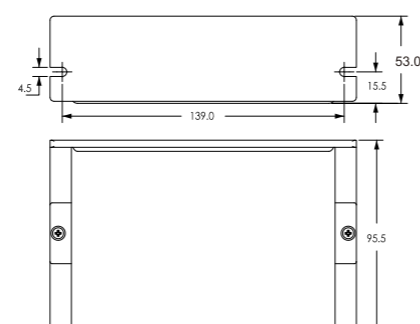

DMA860E

DM Series----AC Power Input

Model	Phase	Power Voltage	Output Current(A)	Control Type	Logical Voltage(VDC)	Mechanical Size(mm)	Matched Motor Size
DMA860H	2	20-80 VAC or 30-110 VDC	2.4-7.2	Step&Dir, CW&CCW	5	151*97*48	NEMA23/24/34
DMA882S	2	20-80 VAC or 30-110 VDC	0.5-8.2	Step&Dir, CW&CCW	5	151*97*48	NEMA23/24/34
DM1182	2	70-130 VAC	0.5-8.2	Step&Dir, CW&CCW	5	202*167*63	NEMA34/42
DM2282	2	180-240 VAC	0.5-8.2	Step&Dir, CW&CCW	5	202*167*63	NEMA34/42/53

DM Series---- 3-phase Type

Model	Phase	Power Voltage	Output Current(A)	Control Type	Logical Voltage(VDC)	Mechanical Size(mm)	Matched Motor Size
3DM580S	3	20-50 VDC	0.5-8.0	Step&Dir, CW&CCW	5	118*76*33	NEMA17/23/24/34
3DM883	3	20-80 VDC	2.2-8.3	Step&Dir, CW&CCW	5	151*97*48	NEMA24/34
3DM2283	3	180-240 VAC	2.2-11.7	Step&Dir, CW&CCW	5	202*167*63	NEMA 34/42/53

■ Dimensions

(unit: mm, 1 inch=25.4 mm)

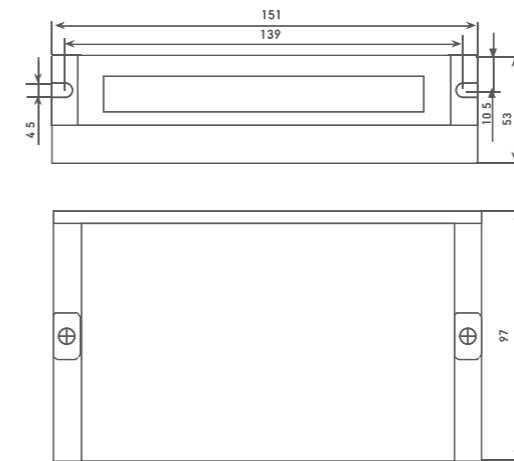

(a) Mechanical specifications of the DMA882S

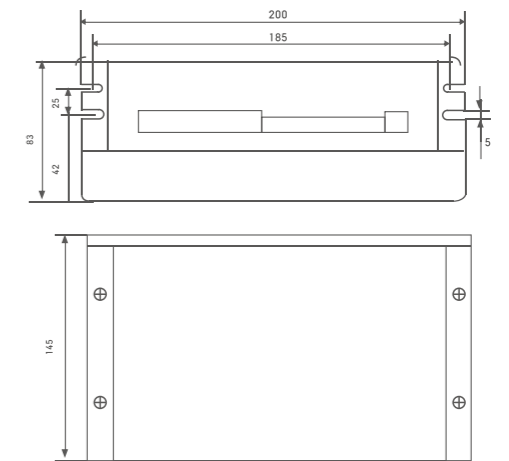

(b) Mechanical specifications of the DM1182

Stepper Motors

CM Series

- Replace HS series stepper motors
- Frame size of NEMA8 to 42
- High reliability, Low motor heating, noise and vibration
- Multiple phase current optional for the same motor



Introduction

By implementing latest design and advanced manufacturing technologies, Leadshine offers hybrid stepper motors in wide frame sizes 8, 11, 14, 16, 17, 23, 24, 34, and 42. Those stepper motors are made of premium quality materials. Compared with ordinary stepper motors on the market. Those stepper motors outperforms in many aspects such as higher torque in all speed ranges, higher precision, lower heating, and lower vibration. Due to the implementation of highly automated manufacturing process and rigid quality assurance control, Leadshine CM series stepper motors are highly reliable with high product consistency.

High Torque:

Latest design for compact size but high torque

Smooth Motion:

Core components from global leading suppliers.

Low Heating:

Use of high quality silicon steel to ensure low motor heating.

High Consistency:

Highly automated manufacturing process and rigid quality control.

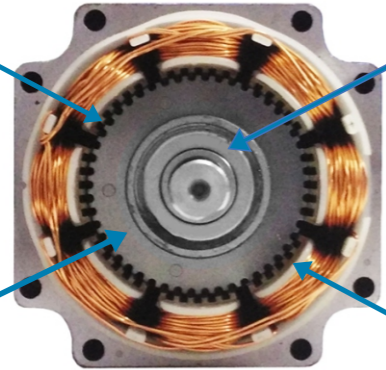

Leadshine CM series stepper motors are available in the following options:

- Standard single shaft stepper motors.
- IP 65 waterproof stepper motors.
- Dual shaft stepper motors.
- Stepper motors with electromagnetic brakes.
- Stepper motors with planetary gearboxes.
- Stepper motors with encoders (also called closed loop stepper motors).
- Stepper motors with encoder, brake, and gearboxes.

Leadshine CM stepper motors have been widely implemented in many industrial applications such as CNC routers, laser cutters, plasmas, plotters, medical equipment, battery manufacturing product lines, textile machines, packaging machines, etc.

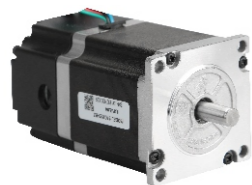

Stepper Motor with brake



CM Series Stepper Motor



Permanent magnet brake

Low noise
Quick response
Low heat

CM series waterproof stepper motor, compared with the standard type, the back cover is redesigned, the lead wire is changed to waterproof connector, new sealing material is added between the front & back cover and the body, the motor body is made a comprehensive waterproof treatment, the motor shaft is selected high quality oil seal, so that the motor IP rate is IP65. can be applied to all kinds of wet, water, outdoor, oil splashing occasions.

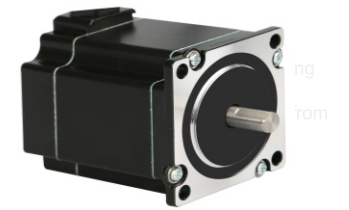

General Specifications

Step Angle	1.8°
Position Accuracy	±0.09°
Temp Rise(Max.)	Max. 85K
Operation Environment	Temperature: -10°C - +50°C; Humidity: Max. 85%
Insulation Class	B
Insulation Resistance	Min. 100 MΩ, 500 V DC
Dielectric Strength	500 VAC, 1 min
Radial Play	0.025 mm Max. (Load 5N)
Axial Play	0.075 mm Max. (Load 10N)

Installation & Operation Conditions

Motor Size	NEMA17	NEMA23	NEMA24	NEMA34
Store Temperature	-10°C ~ +50°C			
Store Humidity	Max. 85%			
Operation Environment	Non-corrosive gas and dust; No direct contact with water, oil (except the waterproof type)			
Radial Load(N) (Distance to the flange 10mm)	30	75	90	300
Axial Load(N)	Less than motor weight			

Stepper Motor Overview

- Below matched drive is default Pulse & Direction type, other control types of drive also can be matched;
- 3-phase stepper motors still keep selling 3S series, others recommend CM series;
- Contact Leadshine for other customized model such as inch shaft diameters, modified cable, etc.

Phase/ Series	Frame Size	Length(mm)	Model	Rate Current (A)	Holding Torque(N.m)	Matched Drives	Remark	
2-Phase/ CM	NEMA 8	33	20CM003	0.6	0.03	EM415S		
		45	20CM005	0.6	0.05	EM415S		
	NEMA 11	32	28CM006	1.2	0.06	EM415S		
		41	28CM010	1.2	0.1	EM415S		
		51	28CM013	1.2	0.13	EM415S		
	NEMA 14	31	35CM015	2.0	0.15	EM422S		
		47	35CM04	2.0	0.4	EM422S		
	NEMA 17	33	42CM02-1A	1.0	0.2	EM415S		
			42CM02	1.5	0.2	EM422S		
		40	42CM04-1A	1.0	0.4	EM415S		
			42CM04	1.5	0.4	EM422S		
		47	42CM06-1A	1.5	0.6	EM422S		
			42CM06	2.5	0.6	EM422S/EM542S	Performance in high-speed	
			42CM06-SZ	2.5	0.6	EM422S/EM542S	Motor with dual shaft	
		60	42CM08-1A	1.5	0.8	EM422S		
			42CM08	2.5	0.8	EM422S/EM542S	Performance in high-speed	
			42CM08-SZ	2.5	0.8	EM422S/EM542S	Motor with dual shaft	
		NEMA 23	41	57CM06	3.0	0.6	EM542S	
			56	57CM13-3A	3.0	1.3	EM542S	
	57CM13			4.0	1.3	EM556S	Performance in high-speed	
	57CM13-SZ			4.0	1.3	EM556S	Motor with dual shaft	
	96		57CM13-BZ	4.0	1.3	EM556S	Motor with brake	
	65		57CM13-FS	4.0	1.3	EM556S	IP65 waterproof	
	76		57CM23-3A	3.0	2.3	EM542S		
			57CM23-4A	4.0	2.3	EM556S		
			57CM23	5.0	2.3	EM556S/EM870S	Performance in high-speed	
	116		57CM23-SZ	5.0	2.3	EM556S/EM870S	Motor with dual shaft	
		57CM23-BZ	5.0	2.3	EM556S/EM870S	Motor with brake		
	90	57CM23-FS	5.0	2.3	EM556S/EM870S	Motor with waterproof		
	84	57CM26-4A	4.0	2.6	EM556S			
		57CM26	5.0	2.6	EM556S/EM870S	Performance in high-speed		
		57CM26-SZ	5.0	2.6	EM556S/EM870S	Motor with dual shaft		
	67	D57CM21-4A	4.0	2.1	EM556S			
		D57CM21	5.0	2.1	EM556S/EM870S	Performance in high-speed		
		D57CM21-SZ	5.0	2.1	EM556S/EM870S	Motor with dual shaft		
	88	D57CM31-4A	4.0	3.1	EM556S			
		D57CM31	5.0	3.1	EM556S/EM870S	Performance in high-speed		
		D57CM31-SZ	5.0	3.1	EM556S/EM870S	Motor with dual shaft		

Phase/Series	Frame Size	Length(mm)	Model	Rate Current (A)	Holding Torque(N.m)	Matched Drives	Remark
2-Phase/ CM	NEMA 34	67	60CM22X	5.0	2.2	EM556S/EM870S	Motor with dual shaft
			60CM22X-SZ	5.0	2.2	EM556S/EM870S	Motor with brake
		110	60CM35X-FS	5.0	2.2	EM556S/EM870S	
		85	60CM30X	5.0	3.0	EM556S/EM870S	
			60CM30X-SZ	5.0	3.0	EM556S/EM870S	Motor with dual shaft
		124	60CM30X-BZ	5.0	3.0	EM556S/EM870S	Motor with brake
		65	86CM35	4.0	3.5	EM556S/EM870S	
		80	86CM45	6.0	4.5	EM882S	
			86CM45-SZ	6.0	4.5	EM882S	Motor with dual shaft
		114	86CM45-BZ	6.0	4.5	EM882S	Motor with brake
		90	86CM45-FS	6.0	4.5	EM882S	Motor with waterproof
		98	86CM80	6.0	8.0	EM882S	
	118	86CM85	6.0	8.5	EM882S		
		86CM85-SZ	6.0	8.5	EM882S	Motor with dual shaft	
	152	86CM85-BZ	6.0	8.5	EM882S	Motor with brake	
	130	86CM85-FS	6.0	8.5	EM882S	Motor with waterproof	
	129	86CM120	6.0	12	EM882S/DM1182		
	NEMA 42/ NEMA 51	115	110CM12	6.0	12	DM2282	
		150	110CM20	6.5	20	DM2282	
		201	110CM28	6.0	28	DM2282	
283		130HS45	7.0	45	DM2282		
3-Phase/ 3S	NEMA 23	50	573S09	3.5	0.9	3DM580S	
		76	573S15	5.8	1.5	3DM580S	
		80	573S20-LS	5.8	1.5	3DM580S	
	NEMA 34	71	863S22	5.0	2.2	3DM883	
		103	863S42	5.0	4.2	3DM883	
		135	863S68H	2.3	6.8	3DM2283	

Phase/Series	Frame Size	Length(mm)	Model	Rate Current (A)	Holding Torque(N.m)	Matched Drives	Remark	
2-Phase/ CM	NEMA 11	51	28CM013-ZK	1.2	0.13	EM415S	Hollow shaft	
	NEMA 17	40	42CM04-ZK	2.5	0.4	EM422S	Hollow shaft	
		79	42CM06-BZ	2.0	0.6	EM422S	Brake	
		88	42CM06-RD05	2.5	0.6	EM422S/EM542S	Gearbox	
		88	42CM06-RD10	2.5	-	EM422S/EM542S	Gearbox	
		95	42CM06-RD20	2.5	-	EM422S/EM542S	Gearbox	
		92	42CM08-BZ	2.0	0.8	EM422S/EM542S	Brake	
		101	42CM08-RD05	2.5	-	EM422S/EM542S	Gearbox	
		101	42CM08-RD10	2.5	-	EM422S/EM542S	Gearbox	
		108	42CM08-RD20	2.5	-	EM422S/EM542S	Gearbox	
		60	42CM08-SZ-ZK	2.5	0.8	EM422S/EM542S	Hollow shaft	
		NEMA 23	55	57CM12C-3A-CZ	3.0	1.2	EM542S	Plug-in terminals
			55	57CM12C-ZK	4.0	1.2	EM542S/EM556S	Hollow shaft
	110		57CM12C-RD05	4.0	-	EM542S/EM556S	Gearbox	
	110		57CM12C-RD10	4.0	-	EM542S/EM556S	Gearbox	
	76		57CM22C-4A-I6-CZ	4.0	2.2	EM556S	Plug-in terminals	
	131		57CM22C-RD05	5.0	-	EM556S	Gearbox	
	131		57CM22C-RD10	5.0	-	EM556S	Gearbox	
	NEMA 34		98	86CM80-ZK	6.0	8.0	EM556S	Hollow shaft

Standard Stepper Motor Specifications

NEMA 8 (20mm)

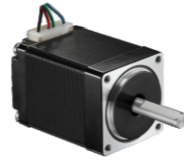

Standard Model:

Model	Length (mm)	Holding Torque(N.m)	Rate Current (A)	Resistance/Phase(Ω)	Inductance/Phase(mH)	Inertia (10 ⁻⁴ kgm ²)	Matched Drives
20CM003	33	0.03	0.6	5.7	2.6	0.003	EM415S
20CM005	45	0.05	0.6	7	3.4	0.004	EM415S

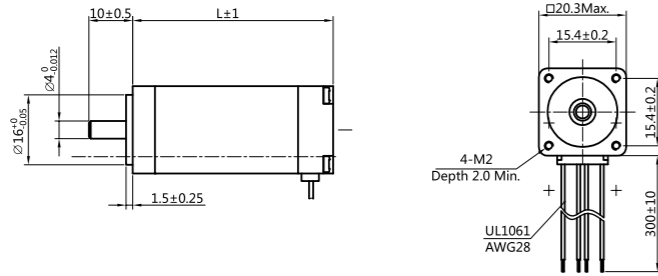

NEMA 11 (28mm)

Standard Models:

Model	Length L(mm)	Holding Torque(N.m)	Rate Current (A)	Resistance/Phase(Ω)	Inductance/Phase(mH)	Inertia (10 ⁻⁴ kgm ²)	Matched Drives
28CM006	32	0.06	1.2	1.4	1.0	0.009	EM415S
28CM010	41	0.1	1.2	1.8	1.6	0.013	EM415S
28CM013	51	0.13	1.2	2.2	2.3	0.018	EM415S

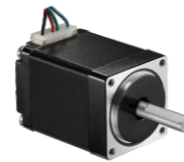

Unit: mm 1inch=25.4mm

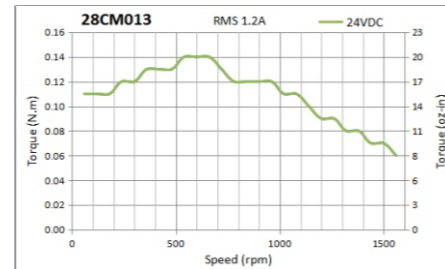
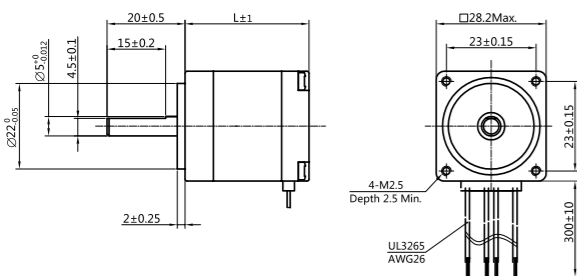

NEMA 14 (35mm)

Standard Models:

Model	Length L(mm)	Holding Torque(N.m)	Rate Current (A)	Resistance/Phase(Ω)	Inductance/Phase(mH)	Inertia (10 ⁻⁴ kgm ²)	Matching Drives
35CM015	31	0.15	2	0.8	1.3	0.019	EM422S
35CM04	47	0.36	2	1.2	1.9	0.026	EM422S

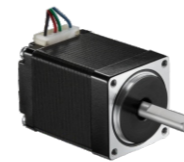

Unit: mm 1inch=25.4mm

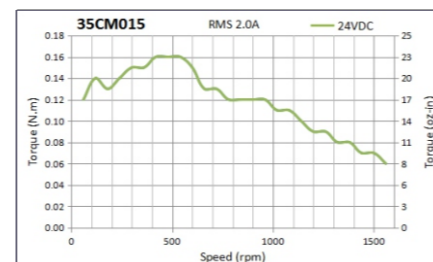
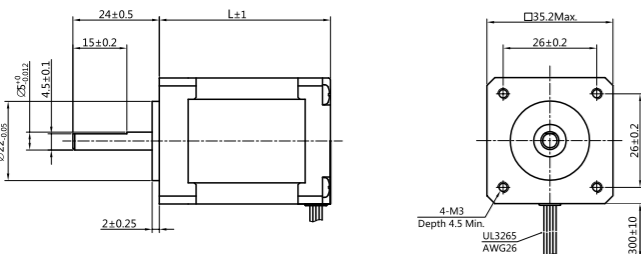

NEMA 17 (42mm)

Standard Models:

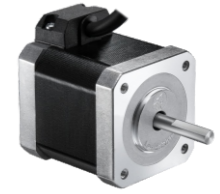

Model	Length L(mm)	Holding Torque(N.m)	Rate Current (A)	Resistance/Phase(Ω)	Inductance/Phase(mH)	Inertia (10 ⁻⁴ kgm ²)	Matching Drives
42CM02-1A	33	0.21	1	4.5	6.5	0.035	EM415S
42CM02		0.21	1.5	1.4	1.4	0.035	EM422S
42CM04-1A	40	0.4	1	4.0	7.9	0.054	EM415S
42CM04		0.4	1.5	2.3	4.3	0.054	EM422S
42CM06-1A	47	0.6	1.5	2.2	4.5	0.072	EM422S
42CM06		0.6	2.5	0.9	1.6	0.072	EM532MINI
42CM08-1A	60	0.8	1.5	3.0	6.9	0.110	EM422S
42CM08		0.8	2.5	1.0	2.4	0.110	EM532MINI

Unit: mm 1inch=25.4mm

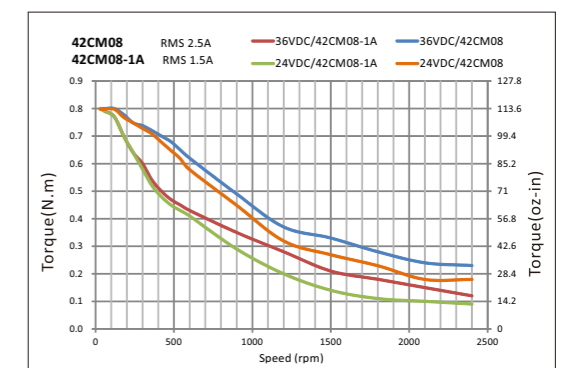
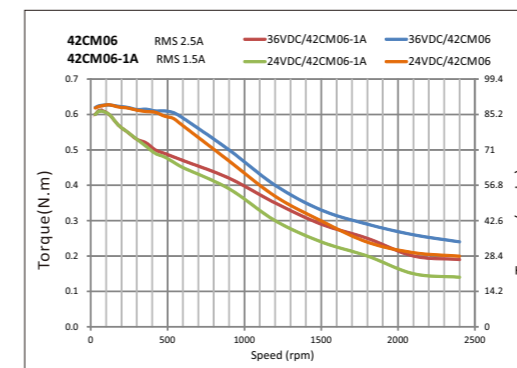
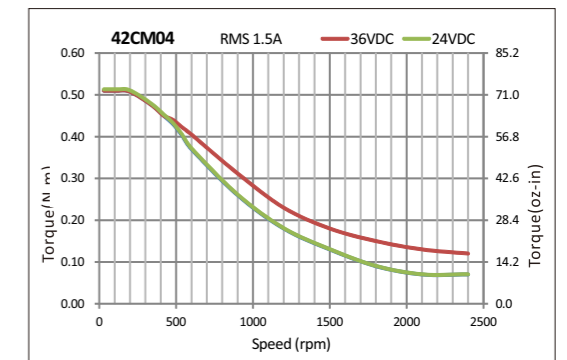
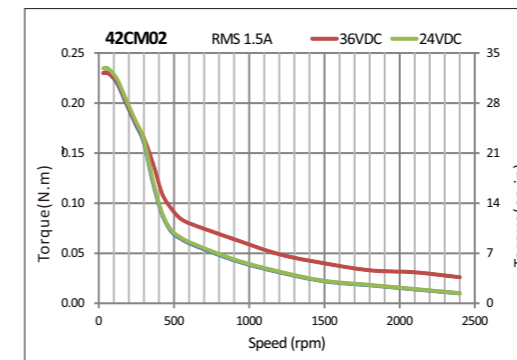
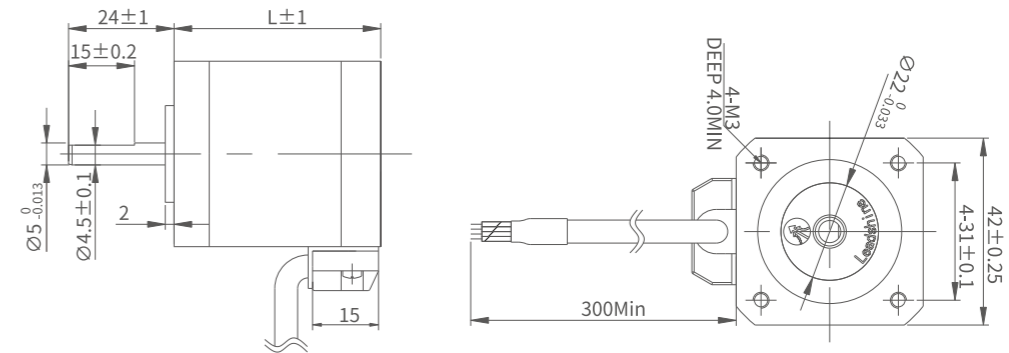

NEMA 23 (57mm)



Standard Models:

Model	Length L(mm)	Holding Torque(N.m)	Rate Current (A)	Resistance/Phase(Ω)	Inductance/Phase(mH)	Detent Torque	Inertia (10 ⁻⁴ kgm ²)	Matching Drives
57CM06	41	0.6	3	0.7	1.4	0.02	0.12	EM542S
57CM13-3A	55	1.3	3	0.8	2.8	0.04	0.3	EM542S
57CM13		1.3	4	0.42	1.6			EM542S/EM556S
57CM12X		1.2	4	0.6	1.4			EM542S/EM556S
57CM21X	76	2.1	4	0.6	2.4	0.07	0.48	EM542S/EM556S
57CM23-3A		2.1	3	1.1	4.2			EM542S
57CM23-4A	76	2.3	4	0.5	2	0.07	0.5	EM542S/EM556S
57CM23		2.3	5	0.38	1.75			EM556S
57CM22X	80	2.2	5	0.34	1.74	0.07	0.5	EM556S/EM870S
57CM26-4A	85	2.6	4	0.8	3.2	0.08	0.52	EM542S/EM556S
57CM26		2.6	5	0.44	2			EM556S/EM870S

Note: Motors with 1/4 in(6.35mm) shaft diameter are available.

Unit: mm 1inch=25.4mm

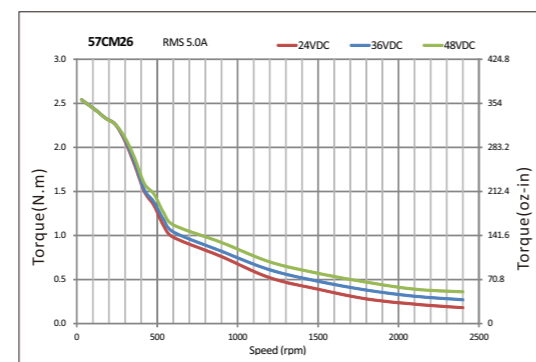
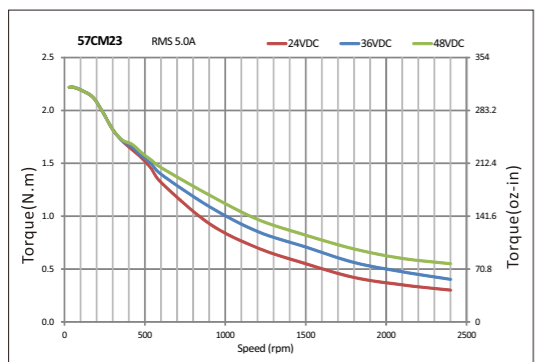
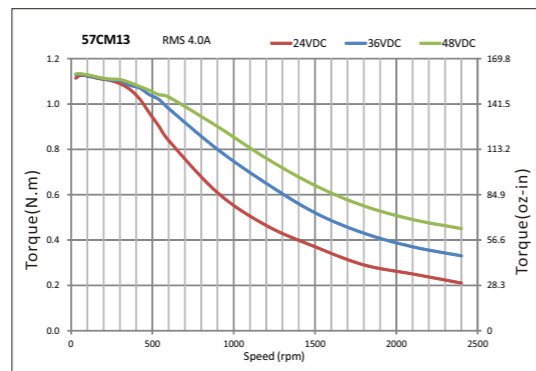
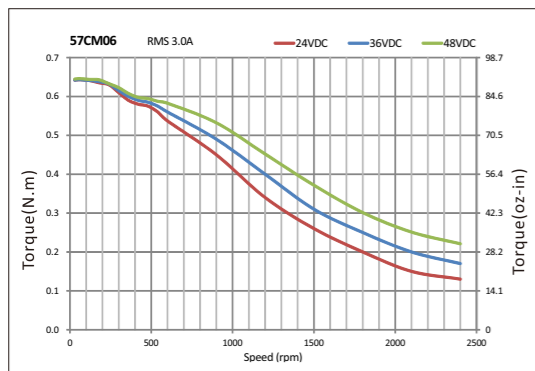
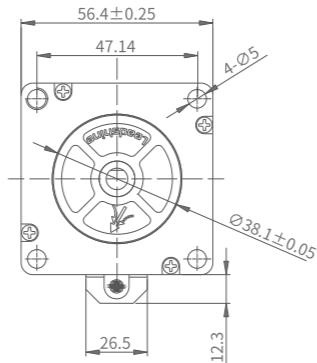
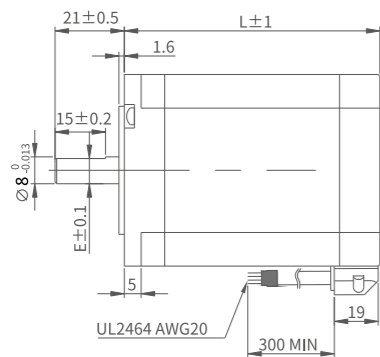

NEMA 23 (57mm)

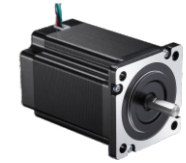

Standard Models:

Model	Length L(mm)	Holding Torque(N.m)	Rate Current (A)	Resistance/Phase(Ω)	Inductance/Phase(mH)	Detent Torque (N.m)	Inertia (10 ⁻⁴ kgm ²)	Matching Drives
D57CM21-4A	67	2.1	4	0.5	1.77	0.09	0.57	EM556S
D57CM21		2.1	5	0.21	0.75			EM556S/EM870S
D57CM31-4A	88	3.1	4	0.62	2.8	0.10	0.84	EM556S
D57CM31		3.1	5	0.26	1.18			EM556S/EM870S

Unit: mm 1inch=25.4mm

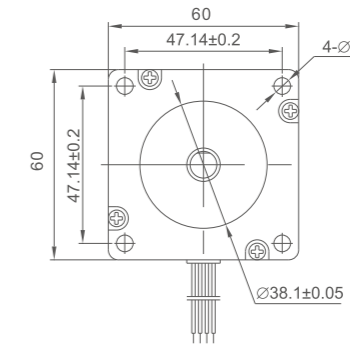
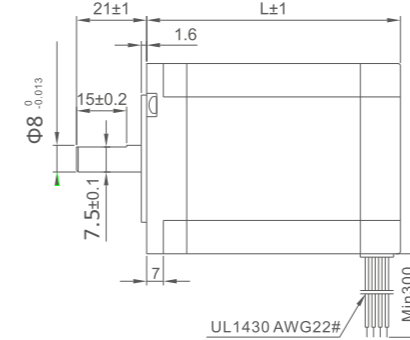

NEMA 24 (60mm)

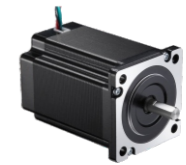

Standard Models:

Model	Length L(mm)	Holding Torque(N.m)	Rate Current (A)	Resistance/Phase(Ω)	Inductance/Phase(mH)	Detent Torque(N.m)	Inertia (10 ⁻⁴ kgm ²)	Matching Drives
60CM22X	67	2.2	5	0.33	1.05	0.07	0.49	EM556S/EM870S
60CM30X	85	3.0	5	0.46	2.0	0.08	0.69	EM556S/EM870S

Unit: mm 1inch=25.4mm

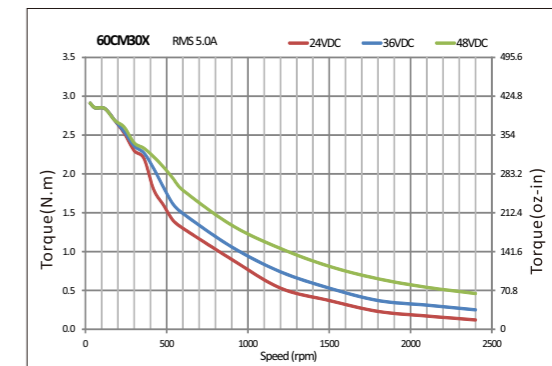
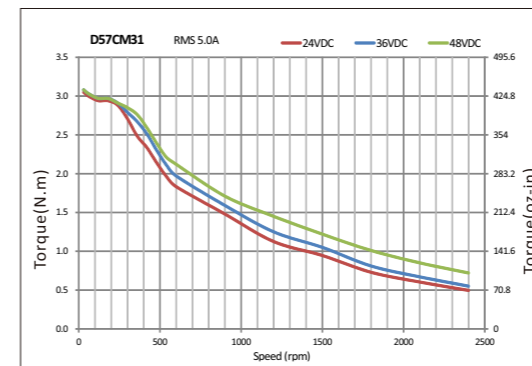
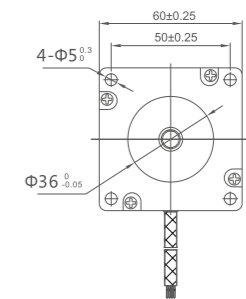
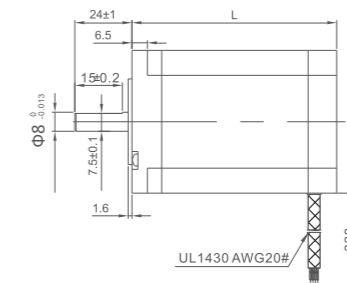

NEMA 34 (86mm)



Standard Models:

Model	Length L(mm)	Holding Torque(N.m)	Rate Current (A)	Resistance/Phase(Ω)	Inductance/Phase(mH)	Inertia (10 ⁻⁴ kgm ²)	Matching Drives
86CM35	65	3.5	4	0.42	2.67	1.00	EM556S/EM870S
86CM45	80	4.5	6	0.43	2.95	1.40	EM882S
86CM80	98	8.0	6	0.63	4.0	2.50	EM882S
86CM85	118	8.5	6	0.53	4.25	2.70	EM882S
86CM120	129	12.0	6	0.75	5.30	2.94	EM882S/DMA882S

Note: Motors with 14mm shaft diameter are available.

Unit: mm 1inch=25.4mm

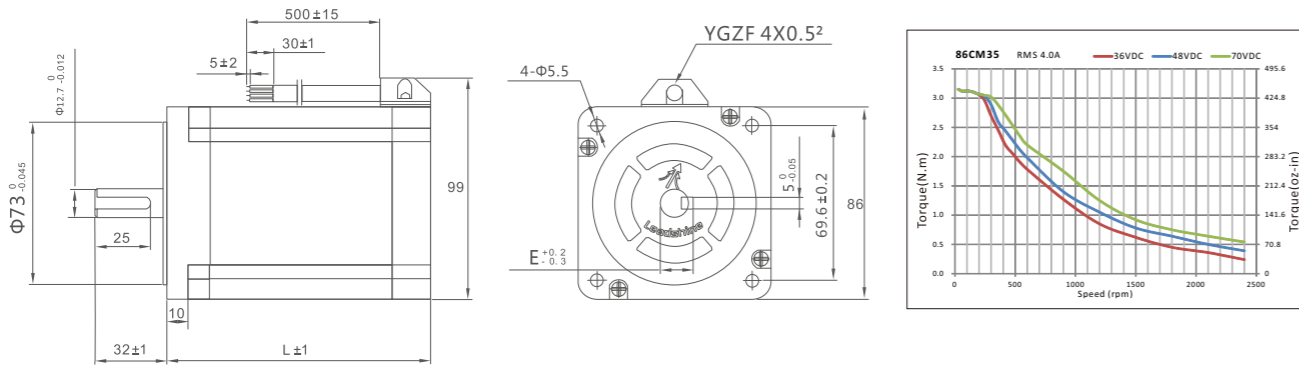

NEMA 42 & 51 (110mm & 130mm)



Standard Models:

Model	Length L(mm)	Holding Torque(N.m)	Rate Current (A)	Resistance/Phase(Ω)	Inductance/Phase(mH)	Inertia (10 ⁻⁴ kgm ²)	Matching Drives
110CM12	115	12	6	0.53	6.5	7.2	DM2282
110CM20	150	20	6	0.8	15	10.9	DM2282
110CM28	201	28	6.5	1.2	22	16.2	DM2282
130HS27	227	27	6	0.86	12.5	15.7	DM2282
130HS45	283	45	7	0.66	9.0	22.9	DM2282

Unit: mm 1inch=25.4mm

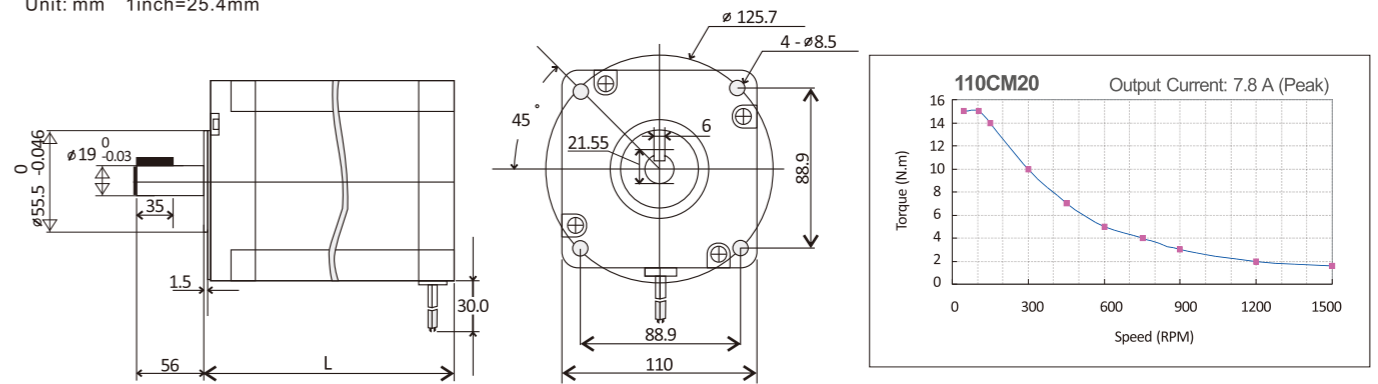

Unit: mm 1inch=25.4mm

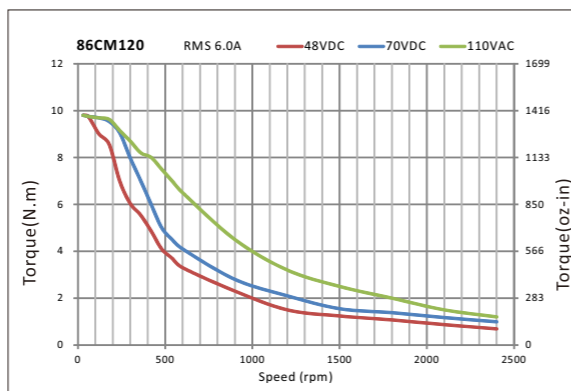
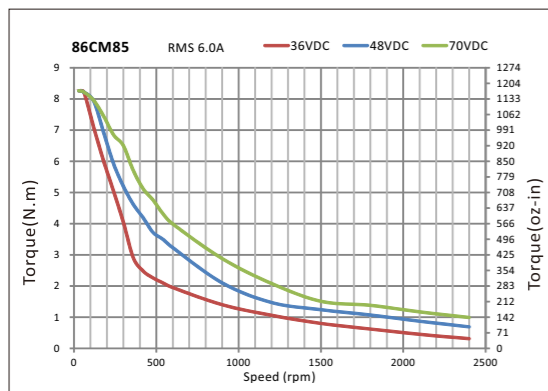
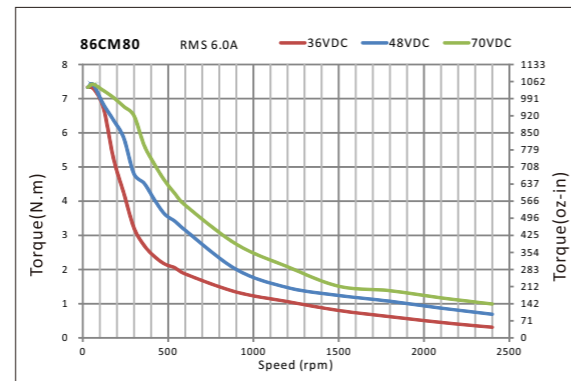
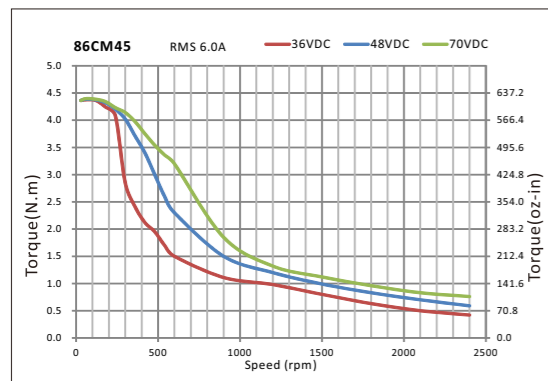
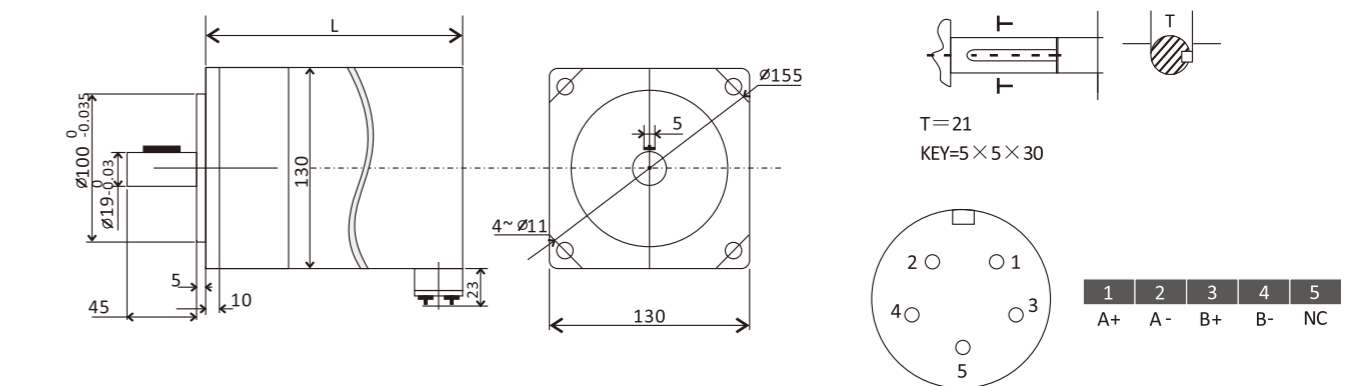

3-phase:NEMA 23, 34, 42

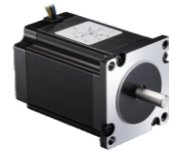

Standard Models:

Model	Length L(mm)	Holding Torque(N.m)	Rate Current (A)	Resistance/Phase(Ω)	Inductance/Phase(mH)	Inertia (10 ⁻⁴ kgm ²)	Matching Drives
573S09	50	0.9	3.5	0.77	1.8	1.00	3DM580S
573S15	76	1.3	5.8	0.86	2.0	1.40	3DM580S
863S22	71	2.3	5	0.9	2.8	2.50	3ND883
863S42	103	4.3	5	1.35	4.5	2.70	3ND883
863S68H	135	6.8	2.3	4.5	20	2.94	3DM2283

Unit: mm 1inch=25.4mm

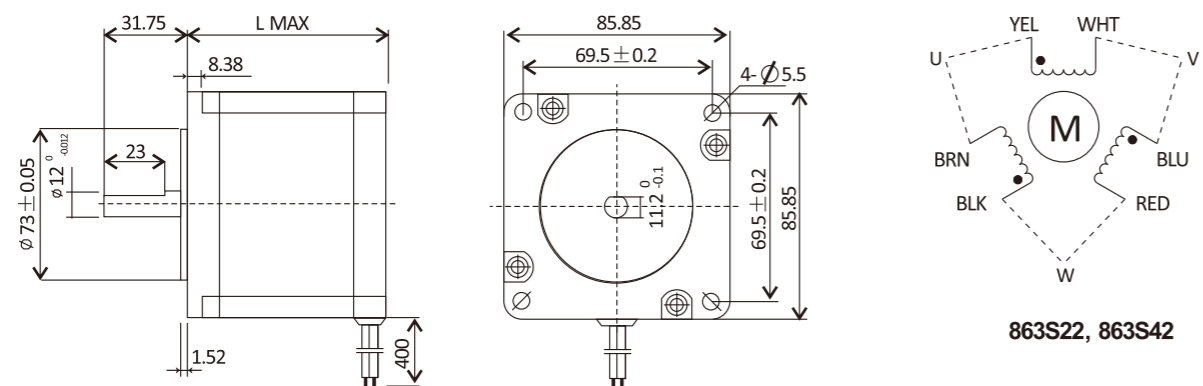
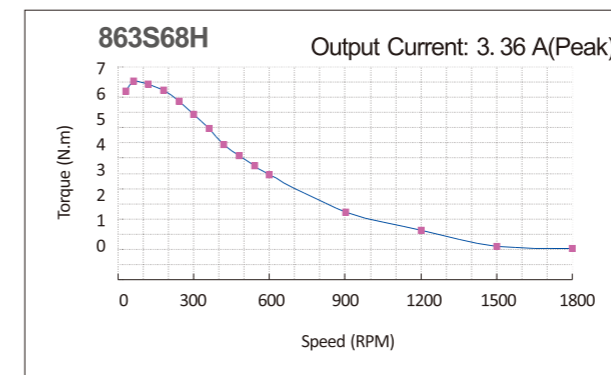
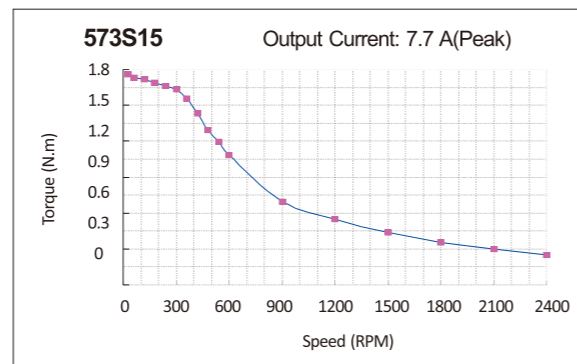
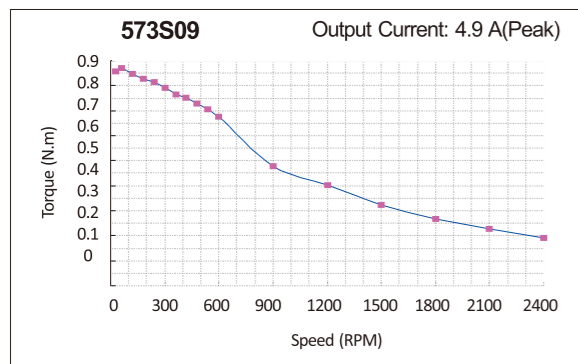
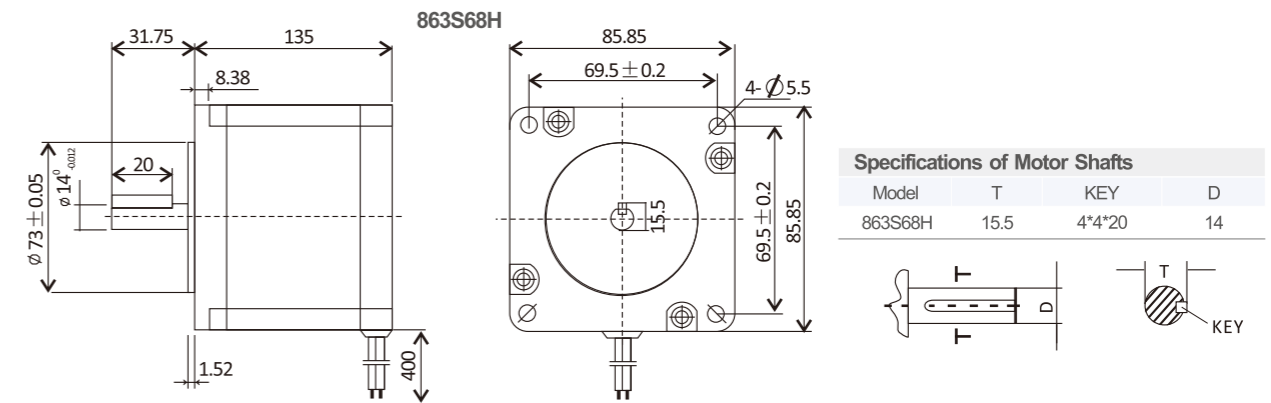
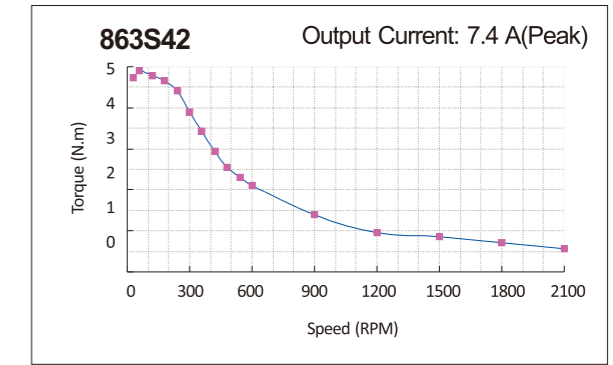
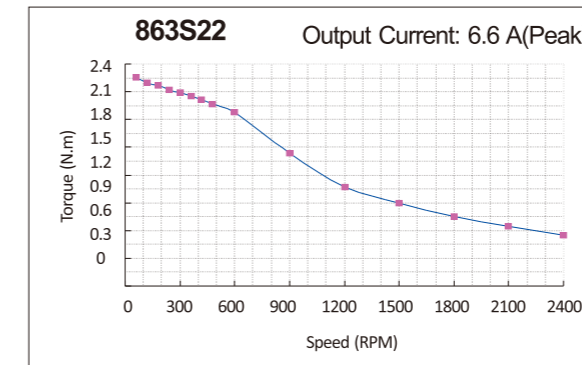
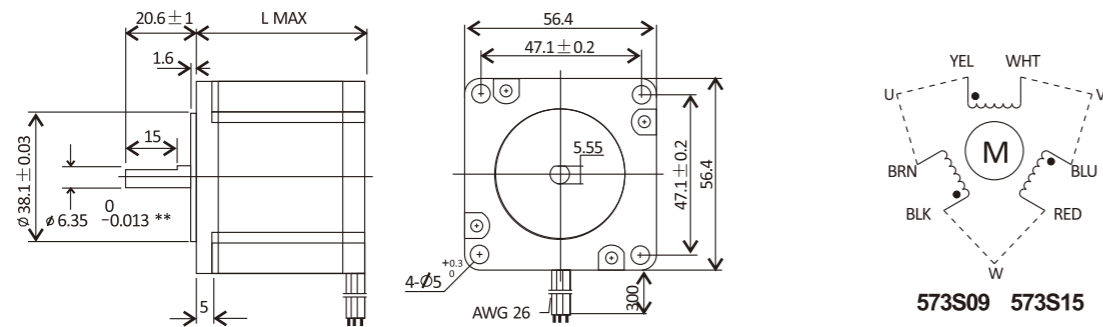

Closed Loop Stepper Products

Closed Loop Stepper Product Part Numbers

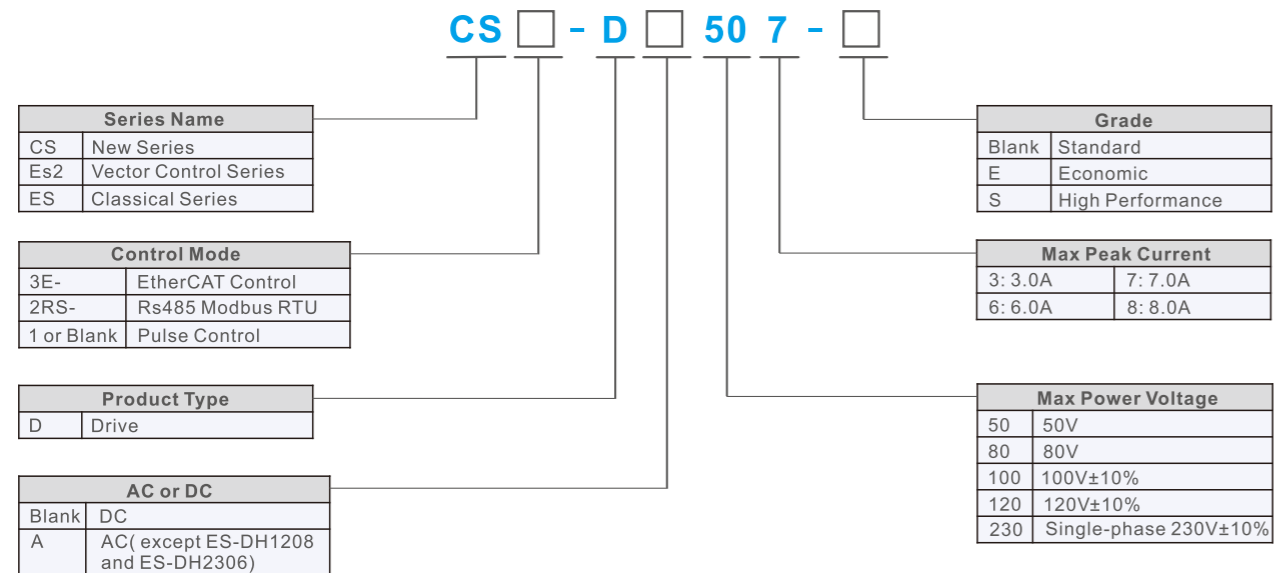

Closed Loop Stepper Motor

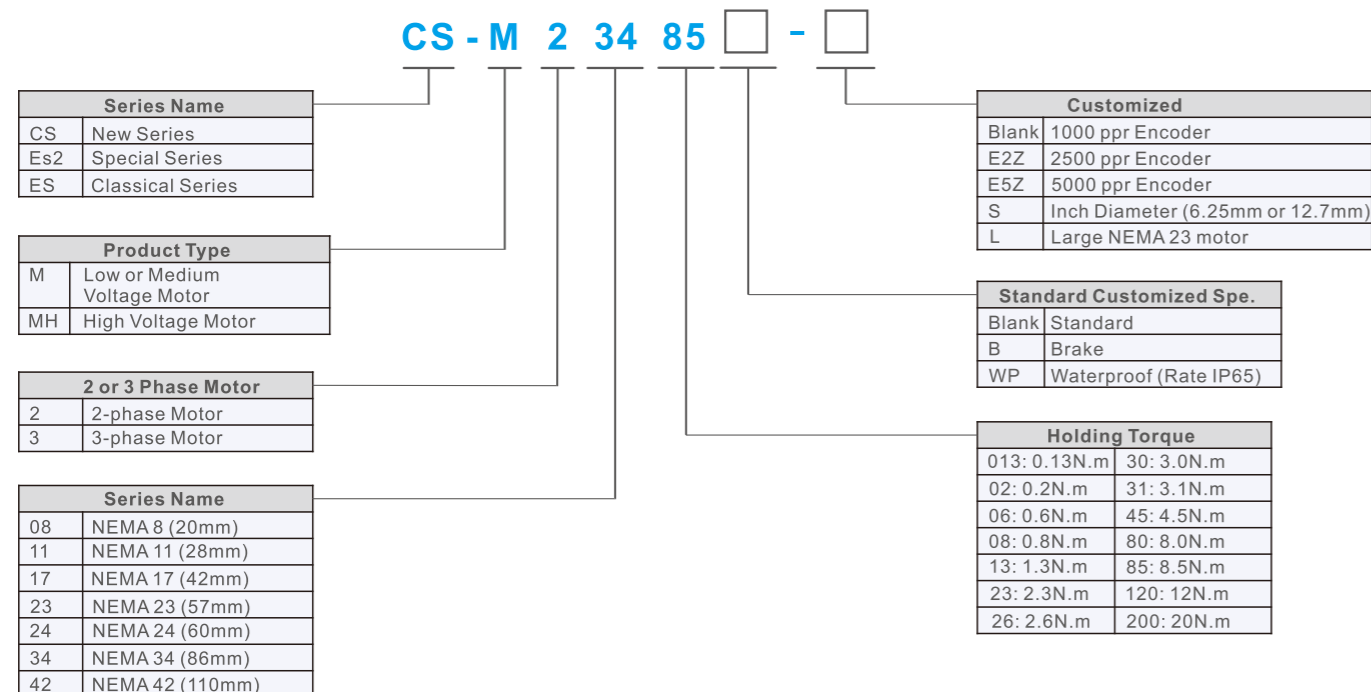

Fieldbus Closed Loop Stepper Drives

CS3E Series



- Support CoE control and CiA 402 protocol
- Matching most of master controller
- Conformance tested by ETG
- No loss of step, Excellent performance

Introduction

The CS3E series drives support operating modes: Cyclic Synchronous Position (CSP), Profile Position (PP), Profile Velocity (PV), Homing(HM). The products can be matched with most of EtherCAT controller/PLC such as Beckhoff, Omron, Trio, etc. They have excellent performance including enhanced reliability, super-low noise, anti-resonance, low-speed ripple smoothing and remains 40% less cost than network servo at least. Can power 2-phase NEMA8,11, 14, 17, 23, 24 and 34 stepper motors with incremental encoder in many industrial applications such as CNC, medical, electronics, packaging...

Features

- ▶ No loss of step, No hunting, No torque reservation
- ▶ CS3E support standard EtherCAT protocol with operation modes of PP, PV, CSP, HM
- ▶ 7 configurable digital inputs, 7 optically isolated digital outputs include brake output
- ▶ USB port for parameters configuration
- ▶ Two 7-segment display velocity or slave ID or operation mode or error code
- ▶ Encoder resolution: 1000 / 5000 line for NEMA11/14/17/23/24/ 34 CS motors
- ▶ Protections for over-voltage, over-current and position following error, encoder wiring error, etc.

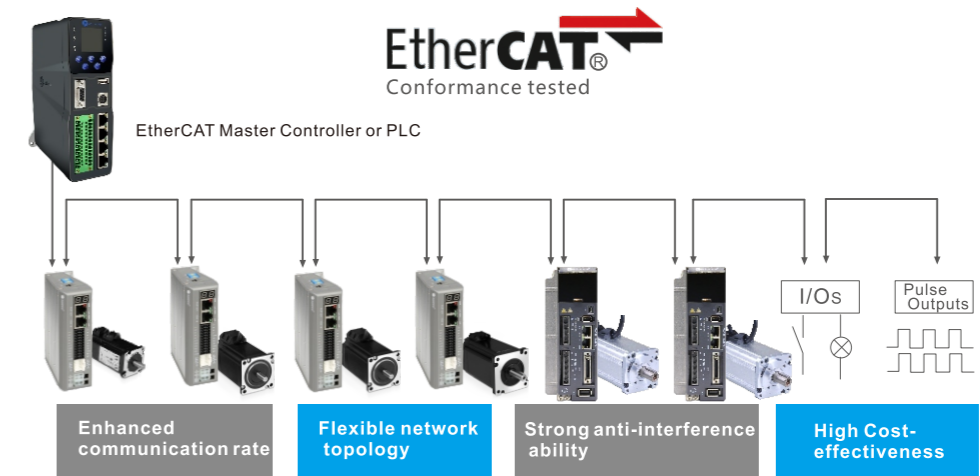

Models	Operating Voltage	Output Current(A)	Matching Motor	Weight(kg)	Dimension(mm)
CS3E-D503	20-50VDC	0.5-3.0	NEMA8/11/14/17	0.28	116*69.2*26.5
CS3E-D507	20-50VDC	0.5-5.6	NEMA17/23/24	0.28	116*69.2*26.5
CS3E-D1008	20-80VAC or 30-110VDC	0.5-8.0	NEMA34	0.85	151*97*52
CABLE-MUSB1M5	Tuning Cable				
CABLE-TX*M*-BUS	Network Cable: 0.1m, 0.2m, 0.3m, 0.4m, 1m, 1.5m, 2m, 3m,5m,7m, 10m,15m, 20m				
CABLEM-BM*M*	Encoder Extension Cable				
CABLEM-RZ*M*	Motor Extension Cable				

2CS3E Series



Dual axis control

- Only occupy the same network node
- The two axes can be controlled independently

Reduce installation space significantly

- Thinner than single shaft drives
- With the same number of axes, only half of the installation space is required

Reduce wire consumption

- Reduce the usage of network communication cables
- Reduce the usage of power cables

Product application is safe and secure

- EtherCAT communication effectively suppresses interference and clutter
- Enhanced version supports dual channel STO

Improve operation convenience significantly

- Spring terminal, plug and play, without IO wire
- MINI USB debugging interface, more convenient for parameter debugging
- Two sets of dip switches for site address setting, faster and more intuitive

Higher quality assurance

- The digital tube displays the node address, alarm diagnosis, and running status
- CE certification

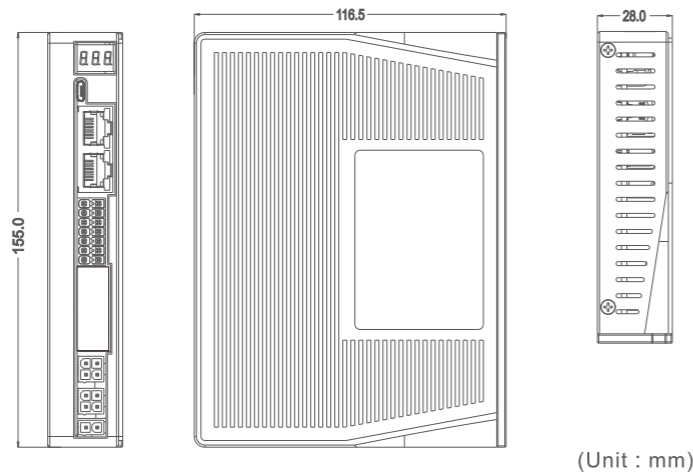

Models	Operating Voltage	Output Current(A)	Matching Motor	Weight(kg)	Dimension(mm)
2CS3E-503	20-50VDC	0.3-3.0	NEMA8/11/14/17	0.4	155*116.5*28
2CS3E-507	20-50VDC	0.5-7.0	NEMA17/23/24	0.4	155*116.5*28
Termination Resistor	The last node needs to add the terminal resistance generally				
CABLE-USB1M5	Tuning cable				
CABLE-TX*M*-BUS	Network Cable: 0.1m, 0.2m, 0.3m, 0.4m, 1m, 1.5m, 2m, 3m,5m,7m, 10m,15m, 20m				

Fieldbus Closed Loop Stepper Drives

2CS3EIP Series



- Support EtherNet/IP fieldbus
- Matching most of master controller
- No loss of step, Excellent performance



Dual axis control

- Only occupy the same network node
- The two axes can be controlled independently

Reduce installation space significantly

- Thinner than single shaft drives
- With the same number of axes, only half of the installation space is required

Reduce wire consumption

- Reduce the usage of network communication cables
- Reduce the usage of power cables

Product application is safe and secure

- EtherNET/IP communication effectively suppresses interference and clutter
- Enhanced version supports dual channel STO

Improve operation convenience significantly

- Spring terminal, plug and play, without IO wire
- MINI USB debugging interface, more convenient for parameter debugging
- Two sets of dip switches for site address setting, faster and more intuitive

Higher quality assurance

- The digital tube displays the node address, alarm diagnosis, and running status
- CE certification

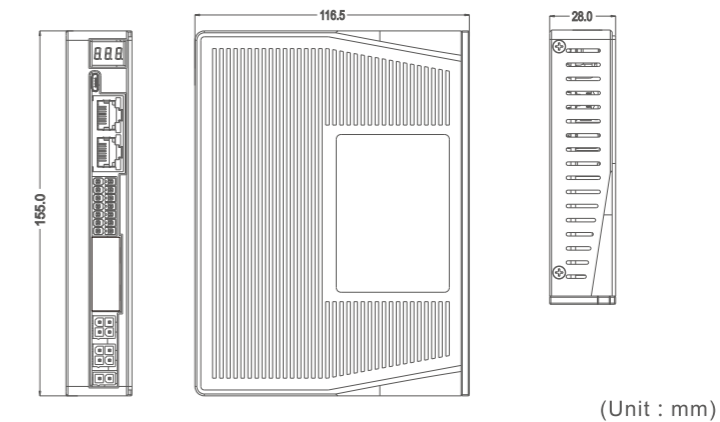

Models	Operating Voltage	Output Current(A)	Matching Motor	Weight(kg)	Dimension(mm)
2CS3EIP-503	20-50VDC	0.3-3.0	NEMA8/11/14/17	0.4	155*116.5*28
2CS3EIP-507	20-50VDC	0.5-7.0	NEMA17/23/24	0.4	155*116.5*28
Termination Resistor	The last node needs to add the terminal resistance generally				
CABLE-USB1M5	Tuning cable				
CABLE-TX*M*-BUS	Network Cable: 0.1m, 0.2m, 0.3m, 0.4m, 1m, 1.5m, 2m, 3m,5m,7m, 10m,15m, 20m				

Fieldbus Closed Loop Stepper Drives CS2RS Series



- Standard Isolated RS485 Modbus
- No loss of step & smooth motion
- Built-in Uni-axial Control Instruction
- HMI, PLC or External I/O start motion

■ Features

- ▶ 7 Programmable Inputs
 - Limit + / - or Origin inputs
 - Emergency stop, Alarm reset and Enable inputs
 - JOG + / - or Position Table inputs
- ▶ 3 Programmable Outputs
 - Alarm, Brake outputs
 - Homing / Instruction / Path complete
- ▶ Modes of Operation
 - Velocity
 - Position
 - Homing
- ▶ Support Functions
 - Teaching
 - Interrupt
 - Skip, Suspend, Circulate motion
- ▶ PC Software for Easy Setup, Fine Tune
- ▶ Matching Motors:
 - NEMA8, 11, 17, 23, 24, 34
 - Standard, dual shaft, brake, waterproof

2. No Loss of step

Adopted closed loop step system to make real-time position error correction, can eliminate potential loss of step.

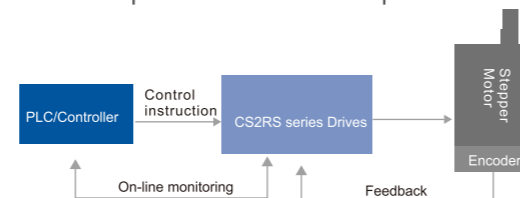

3. Built-in uni-axial control instruction

Programmable 16-segment position table, support positioning/homing/ limit/ quick stop/ JOG...

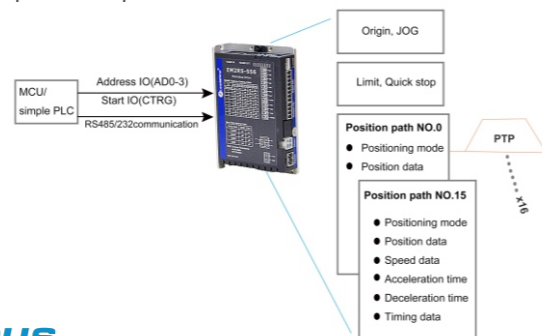

1. Support RS485 communication

Standard Modbus RTU protocol, RS485 communication can network up to 31 axes

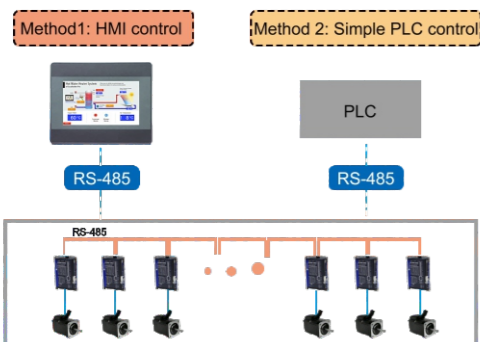

Models	Operating Voltage	Output Current(A)	Matching Motor	Weight(kg)	Dimension(mm)
CS2RS-D503	20-50VDC	0.5-3.0	NEMA8/11/14/17	0.38	116*69.2*26.5
CS2RS-D507	20-50VDC	0.5-7.0	NEMA17/23/24	0.38	116*69.2*26.5
CS2RS-D1008	20-80VAC or 30-100VDC	0.5-8.0	NEMA24/34	0.57	151*97*53
CABLE-PC-1	Tuning Cable				
CABLEM-BM*M*	Encoder Extension Cable				
CABLEM-RZ*M*	Motor Extension Cable				

Pulse Control Closed Loop Stepper Drives



- CS1 Series---Enhanced Version
- CS Series---Cost-effective Version

CS1 Series---Enhanced Performance

■ Inputs and Outputs

- ▶ Step & DIR (CW & CCW) inputs
- ▶ Enable input and Error Reset input
- ▶ Alarm output and In Position output
- ▶ Brake outputs
- ▶ Encoder A/B/Z outputs

■ Switch Settings

- ▶ Microstep resolution
- ▶ Rotation direction
- ▶ Pulse Mode
- ▶ Positional command filter
- ▶ Closed / Open Loop Mode
- ▶ Encoder resolution
- ▶ Gain adjustment and output current
- ▶ 5V or 24V signal voltage optional

■ Pin Assignments

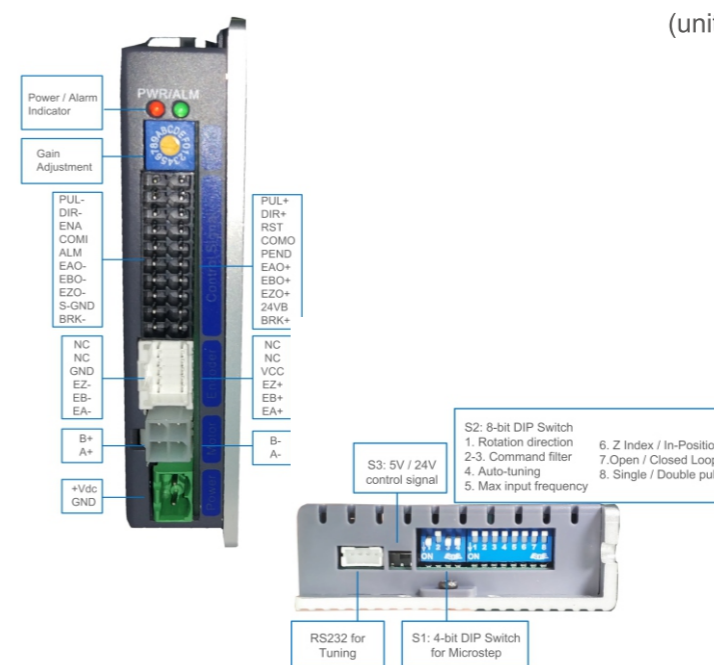

■ Electrical Specifications

Items	CS1-D507S		CS1-D728	
	Min	Max	Min	Max
Output Current (A)	0.5	7	0.5	8
Power Voltage (VDC)	20	50	20	72
Input Frequency (kHz)	-	500	-	500
Input Signal Current(mA)	7	20	7	20
Output Signal Current(mA)	-	100	-	100

■ Dimensions



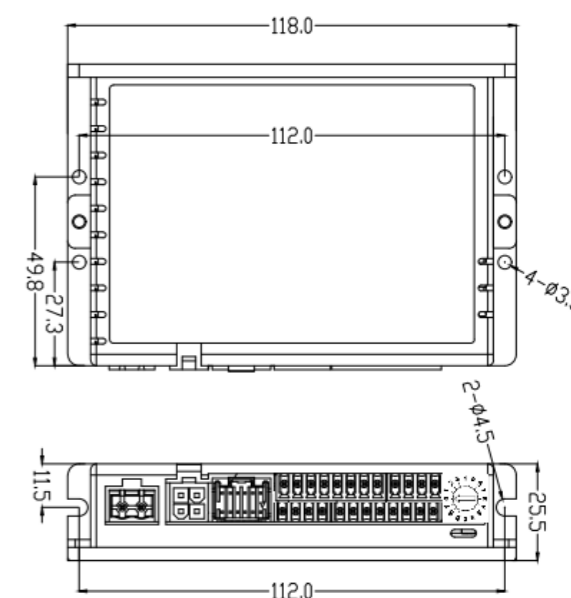

(unit: mm 1 inch=25.4mm)



CS Series----Cost-effective

The CS series consists of ES seasy servo drives adopting Leadshine latest advanced closed loop control technology. Those drives are highly reliable with good performance and highly competitive cost. They can power a wide range of closed loop stepper motors from NEMA 8 to NEMA 34 (model dependent) with incremental encoders. CS series drives are easy to configure and setup.

Electrical Specifications

CS Series Drives				
Model			 NEW	 NEW
	CS-D508	CS-D808	CS-D507E	CS-D1008E
Operating Voltage	20-50VDC	20-80VDC	20-50VDC	20-80VAC or 30-110VDC
Peak Output Current	0.5-7.0A	0.5-8.0A	0.5-7.0A	0.5-8.0A
Control Signal Voltage	5V		5/24V	
Max. Input Frequency	200KHz (500kHz optional)			

Dimensions

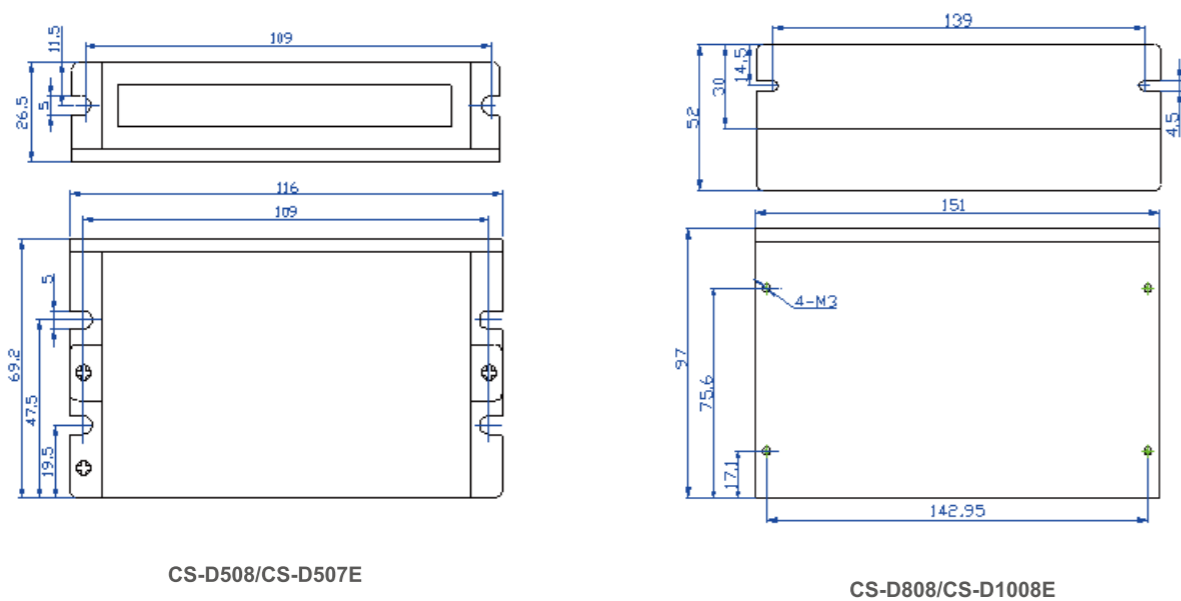

Closed Loop Stepper Motors

CS-M Series

- Replace ES-M series easy servo motor
- Frame size of NEMA 8 to 34
- High reliability and high precision
- Reliable encoder solution



Introduction

CS-M series closed loop stepper motor integrated the CM series stepper motor and encoder, which can provide large torque, low heat and reliable position feedback signals. CS-M series also includes the types with brake, waterproof and different resolution. As a result of large-scale automated production lines and strict quality management system, CS-M series motors are more stable, reliable, superior, consistent and has a lower lost. [Most of ES-M easy servo motors will be replaced by CS-M motors.](#)

Encoder Specifications

Encoder Resolution	1000 ppr, 2500 ppr, 5000 ppr
Encoder Current	Typical 56mA /Max. 59mA
Low Level	0.4v@20mA Max
High Level	2.4v@-20mA Min

Motor Specifications

Step Angle	1.8°
Position Accuracy	±0.09°
Temp Rise(Max.)	Max. 85K
Operation Environment	Temperature: -10°C ~ +50°C; Humidity: Max. 85%
Insulation Class	B
Insulation Resistance	Min.100 MΩ, 500 V DC
Dielectric Strength	500 VAC, 1 min
Radial Play	0.025 mm Max. (Load 5N)
Axial Play	0.075 mm Max. (Load 10N)

Installation & Operation Conditions

Motor Size	NEMA17	NEMA23	NEMA24	NEMA34
Store Temperature	-10°C ~ +50°C			
Store Humidity	85% Max.			
Operation Environment	Non-corrosive gas and dust; No direct contact with water, oil (except the waterproof type)			
Radial Load(N) (Distance to the flange 10mm)	30	75	90	300
Axial Load(N)	Less than motor weight			

Closed Loop Stepper Motor Overview

1. Below matched drives are Pulse Control type, EtherCAT and Modbus RS485 types are also available;
2. 3-phase high voltage closed loop stepper motors are ES2-MH series, others are CS-M series;
3. Contact Leadshine for other model such as NEMA 8 to NEMA14 motors, inch shaft diameter, etc.

Phase/ Series	Frame Size	Length(mm)	Model	Holding Torque(N.m)	Matching Drives	Remark	
2-phase/ CS-M	NEMA 17	56	CS-M21702	0.2	CS-D507E/CS1-D507S		
		63	CS-M21704	0.4	CS-D507E/CS1-D507S	This motor is not recommended	
		70	CS-M21706	0.6	CS-D507E/CS1-D507S		
		83	CS-M21708	0.8	CS-D507E/CS1-D507S		
		60	CS-M22306	0.6	CS-D507E/CS1-D507S		
	NEMA 23	75	CS-M22313	1.3	CS-D507E/CS1-D507S	Replace ES-M22310	
		109	CS-M22313B	1.3	CS-D507E/CS1-D507S	Motor with brake	
		94	CS-M22313WP	1.3	CS-D507E/CS1-D507S	Motor with waterproof	
		95	CS-M22323	2.3	CS-D507E/CS1-D507S	Replace ES-M22320	
		131	CS-M22323B	2.3	CS-D507E/CS1-D507S	Motor with brake	
		115	CS-M22323WP	2.3	CS-D507E/CS1-D507S	Motor with waterproof	
		103	CS-M22326	2.6	CS-D507E/CS1-D507S		
		86	CS-M22321-L	2.1	CS-D507E/CS1-D507S	NEMA23 motor with large body	
		105	CS-M22331-L	3.1	CS-D507E/CS1-D507S	NEMA23 motor with large body	
		NEMA 24	89	CS-M22422	2.2	CS-D507E/CS1-D507S	
			129	CS-M22422B	2.2	CS-D507E/CS1-D507S	Motor with brake
			113	CS-M22422WP	2.2	CS-D507E/CS1-D507S	Motor with waterproof
			107	CS-M22430	3.0	CS-D507E/CS1-D507S	
	143		CS-M22430B	3.0	CS-D507E/CS1-D507S	Motor with brake	
	130		CS-M22430WP	3.0	CS-D507E/CS1-D507S	Motor with waterproof	
	NEMA 34	95	CS-M23435	3.5	CS-D1008E		
		109	CS-M23445	4.5	CS-D1008E		
		144	CS-M23445B	4.5	CS-D1008E	Motor with brake	
		115	CS-M23445WP	4.5	CS-D1008E	Motor with waterproof	
		127	CS-M23480	8.0	CS-D1008E		
		152	CS-M23480B	8.0	CS-D1008E	Motor with brake	
		133	CS-M23480WP	8.0	CS-D1008E	Motor with waterproof	
		147	CS-M23485	8.5	CS-D1008E		
		182	CS-M23485B	8.5	CS-D1008E	Motor with brake	
		153	CS-M23485WP	8.5	CS-D1008E	Motor with waterproof	
		158	CS-M234120	12	CS-D1008E		
		193	CS-M234120B	12	CS-D1008E	Motor with brake	
	3-phase/ ES2-MH	NEMA 34	164	CS-M234120WP	12	CS-D1008E	Motor with waterproof
			157	ES2-MH33480	8.0	ES-DH2306	
190			ES2-MH33480B	8.0	ES-DH2306	Motor with brake	
162			ES2-MH33480WP	8.0	ES-DH2306	Motor with waterproof	
184			ES2-MH334100	10	ES-DH2306		
218			ES2-MH334100B	10	ES-DH2306	Motor with brake	
NEMA 42		191	ES2-MH334100WP	10	ES-DH2306	Motor with waterproof	
		162	ES2-MH342120	12	ES-DH2306		
		207	ES2-MH342120B	12	ES-DH2306	Motor with brake	
		167	ES2-MH342120WP	12	ES-DH2306	Motor with waterproof	
244	ES2-MH342200	20	ES-DH2306				

Note: Contact Leadshine for Gearboxes and Encoder information.

Phase/Series	Frame Size	Length(mm)	Model	Holding Torque(N.m)	Matching Drives	Remark
2-phase/CS-M	NEMA 8	51	CS-M208003	0.03	CS-D507E	-
	NEMA 11	62	CS-M211013	0.13	CS-D507E	-
	NEMA 17	93	CS-M21704B	0.4	CS-D507E	Brake
		101	CS-M21706B	0.6	CS-D507E	Brake
		113	CS-M21708B	0.8	CS-D507E	Brake
		96	CS-M22323-S	2.3	CS-D507E	1/4-inch shaft diameter
	NEMA 23	96	CS-M22323-E5Z	2.3	CS-D507E	5000-line
		104	CS-M22326-S	2.6	CS-D507E	1/4-inch shaft diameter
		105	CS-M22331-L-S	3.1	CS-D507E	3/8-inch shaft diameter
		107	CS-M22430-I14	3.0	CS-D507E	AC servo flange
		147	CS-M22430B-I14	3.0	CS-D507E	AC servo flange, Brake
	NEMA 24	107	CS-M22430-E5Z	3.0	CS-D507E	5000-line
		143	CS-M22430B-E5Z	3.0	CS-D507E	Brake, 5000-line
		109	CS-M22445-S	4.5	CS-D1008E	1/2-inch shaft diameter
		109	CS-M22445-E5Z	4.5	CS-D1008E	5000-line
		135	CS-M22445B-E5Z	4.5	CS-D1008E	Brake, 5000-line
		127	CS-M23480-S	8.0	CS-D1008E	1/2-inch shaft diameter
		127	CS-M23480-E5Z	8.0	CS-D1008E	5000-line
		147	CS-M23485-S	8.5	CS-D1008E	1/2-inch shaft diameter
		147	CS-M23485-E5Z	8.5	CS-D1008E	5000-line
		172	CS-M23485B-E5Z	8.5	CS-D1008E	Brake, 5000-line
		158	CS-M234120-E5Z	12	CS-D1008E	5000-line
		184	CS-M234120B-E5Z	12	CS-D1008E	Brake, 5000-line

Closed Loop Stepper Motor Specifications

NEMA 17 (42mm)

Standard Models:



Model	Length (mm)	Holding Torque(N·m)	Rated Current (A)	Inertia (10 ⁻⁴ kgm ²)
CS-M21702	56	0.2	1.5	0.023
CS-M21704	63	0.4	1.5	0.045
CS-M21706	70	0.6	2.5	0.077
CS-M21708	83	0.8	2.5	0.11

Unit: mm 1inch=25.4mm

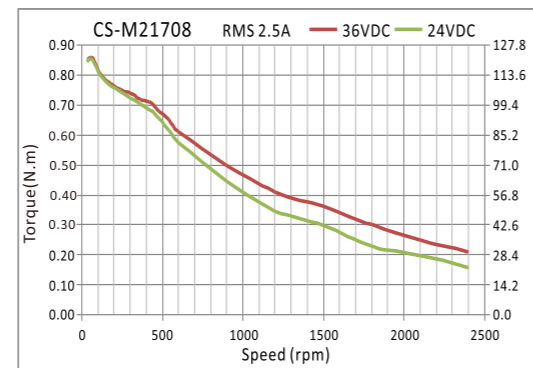
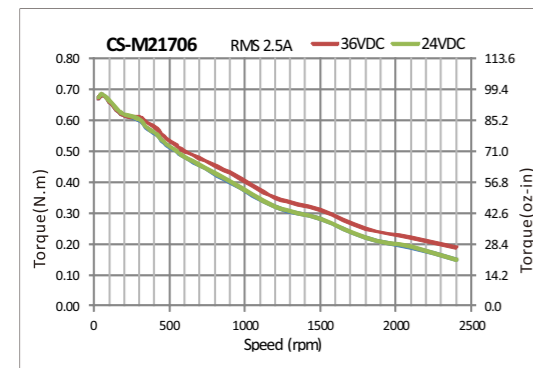
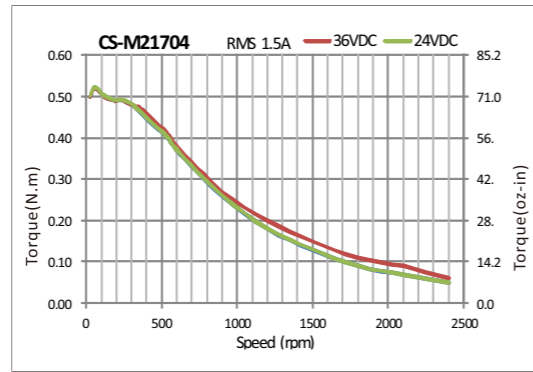
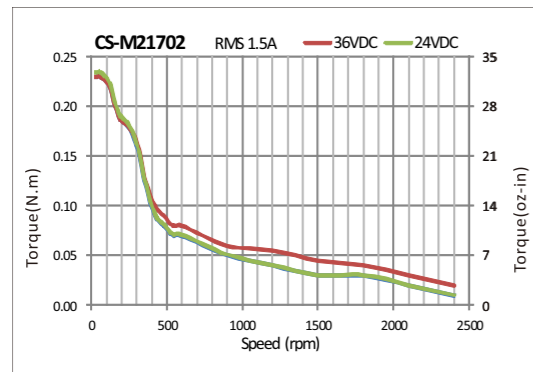
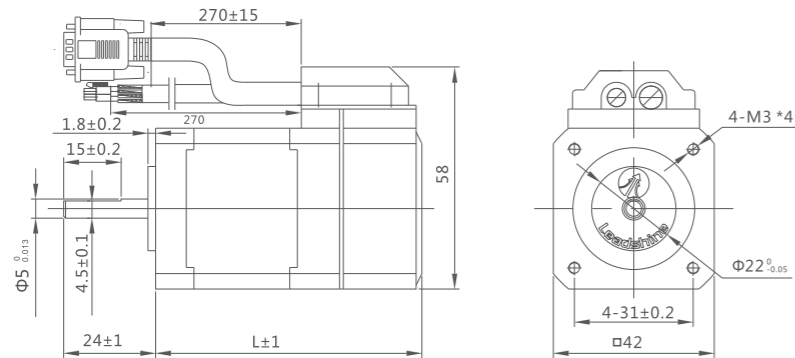

NEMA 23 (57mm)

Standard Models:



Model	Length (mm)	Holding Torque(N·m)	Rated Current (A)	Inertia (10 ⁻⁴ kgm ²)
CS-M22306	60	0.6	3.0	0.131
CS-M22313	75	1.3	4.0	0.3
CS-M22323	95	2.3	5.0	0.48
CS-M22326	103	2.6	5.0	0.7

Note: Motors with 1/4 in(6.35mm) shaft diameter are available.

Unit: mm 1inch=25.4mm

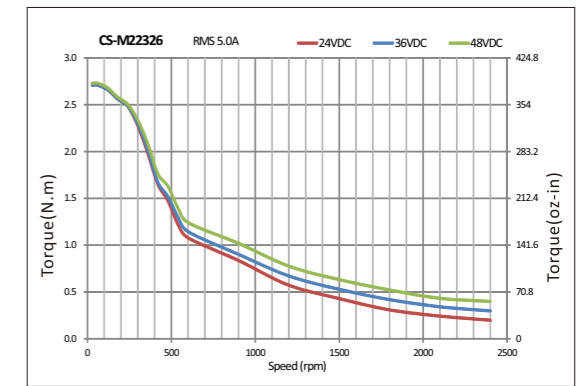
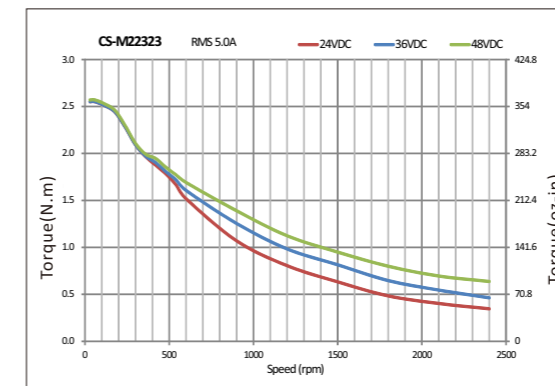
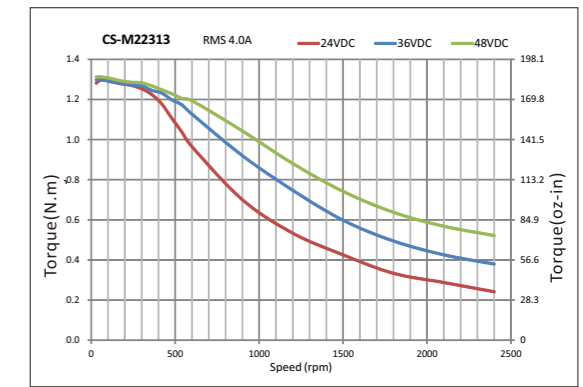
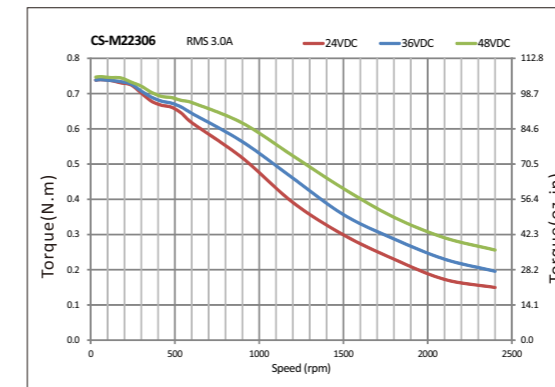
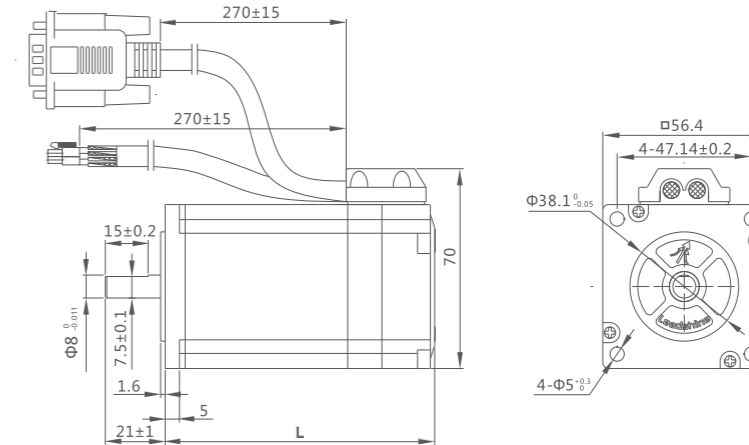

NEMA 23 (57mm)



Standard Models:

Model	Length (mm)	Holding Torque(N·m)	Rated Current (A)	Inertia (10 ⁻⁴ kgm ²)
CS-M22321-L	86	2.1	5.0	0.49
CS-M22331-L	105	3.1	5.0	0.69

Unit: mm 1inch=25.4mm

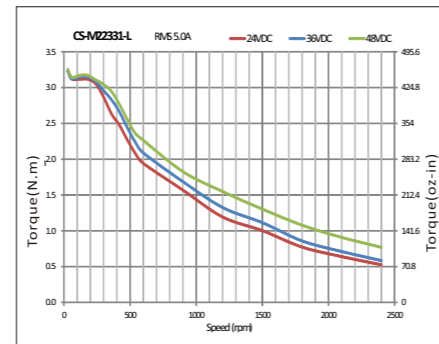
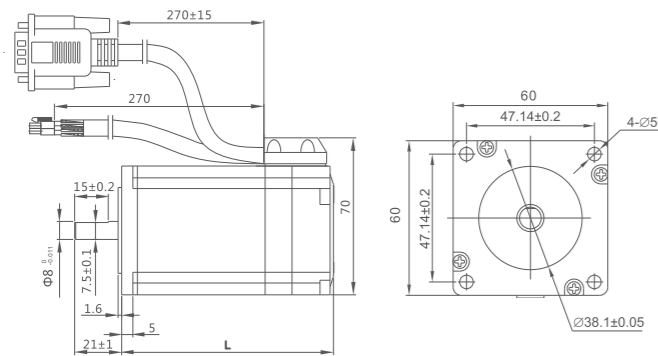

NEMA 24 (60mm)



Standard Models:

Model	Length (mm)	Holding Torque(N·m)	Rated Current (A)	Inertia (10 ⁻⁴ kgm ²)
CS-M22422	86	2.2	5.0	0.49
CS-M22430	103	3.0	5.0	0.69

Unit: mm 1inch=25.4mm

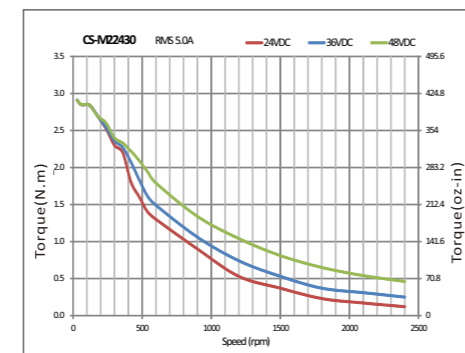
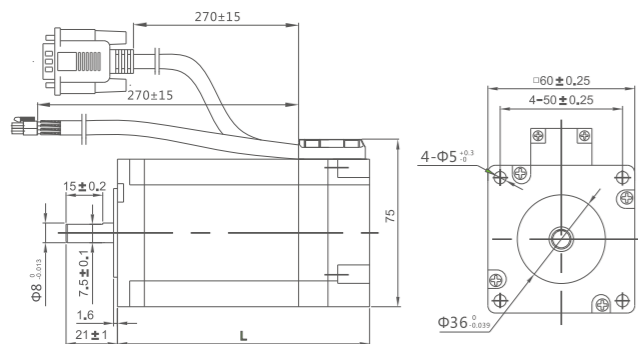

NEMA 34 (86mm)



Standard Models:

Model	Length (mm)	Holding Torque (N·m)	Rated Current (A)	Inertia (10 ⁻⁴ kgm ²)
CS-M23435	95	3.5	4.0	1.0
CS-M23445	109	4.5	6.0	1.95
CS-M23480	127	8.0	6.0	2.5
CS-M23485	147	8.5	6.0	2.8
CS-M234120	158	12.0	6.0	3.0

Note: Motors with 1/2 in(12.7mm) shaft diameter are available.

Unit: mm 1inch=25.4mm

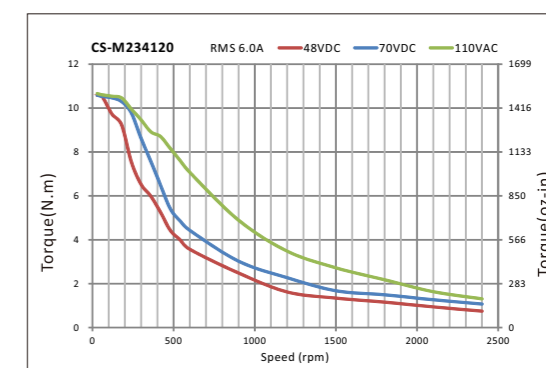
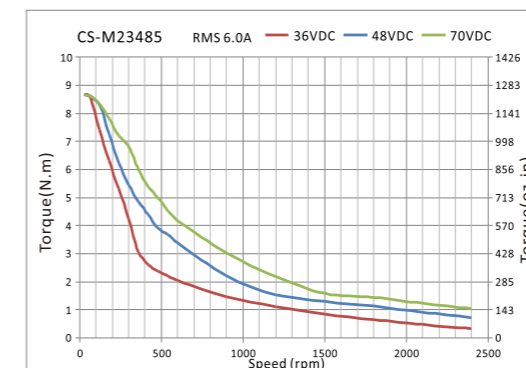
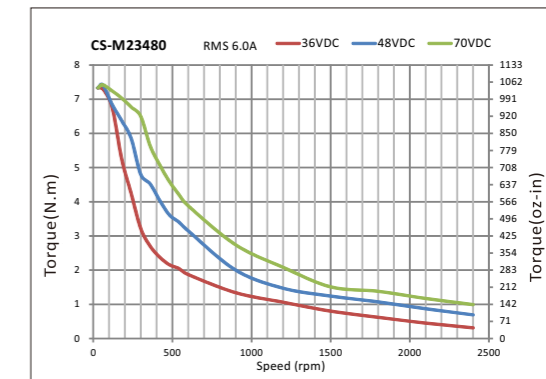
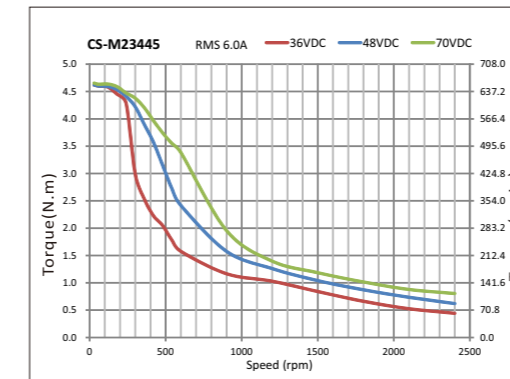
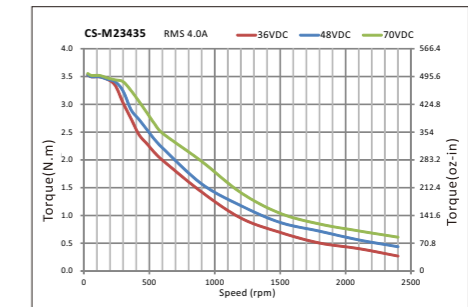
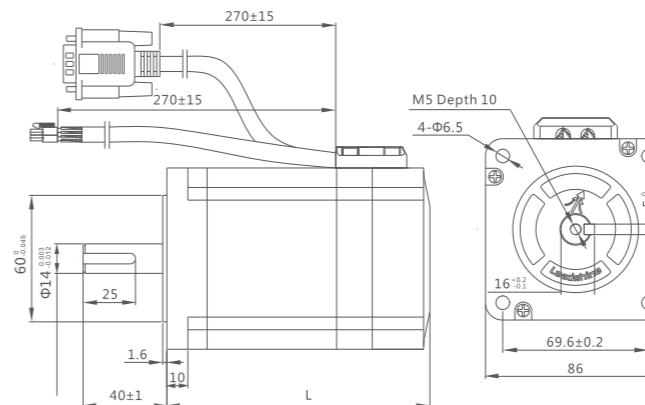

3-phase: NEMA 34, 42

Standard Models:



Model	Length (mm)	Holding Torque (N·m)	Rated Current (A)	Inertia (10^{-4}kgm^2)
ES2-MH33480	158	8.0	6.0	3.0
ES2-MH334100	185	10.0	6.0	3.0
ES2-MH342120	162	12.0	4.2	10.8
ES2-MH342200	244	20.0	5.2	17

Unit: mm 1inch=25.4mm

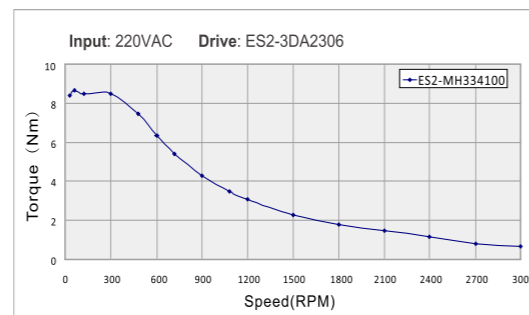
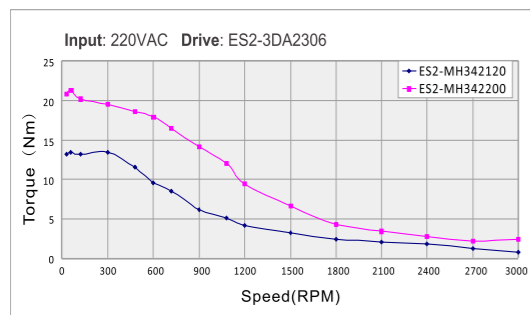
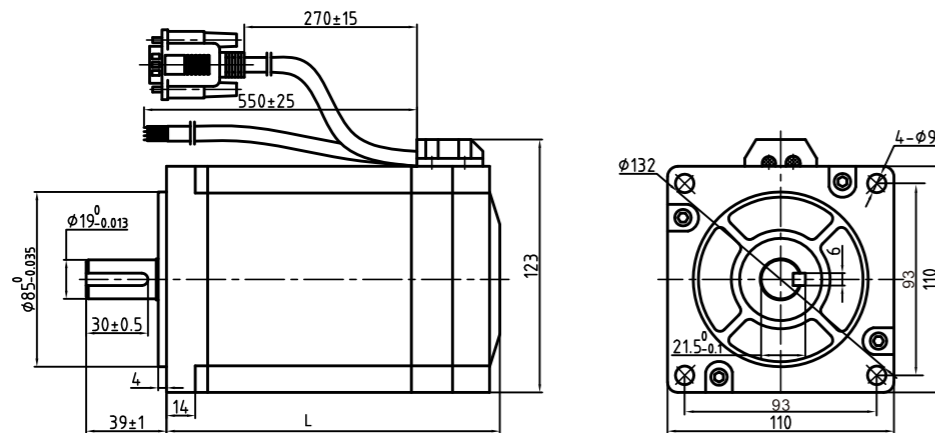
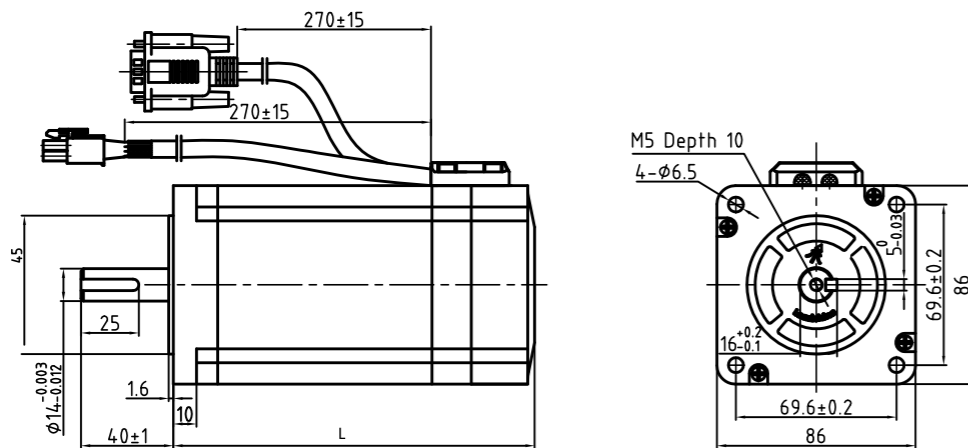

Integrated Stepper Motors

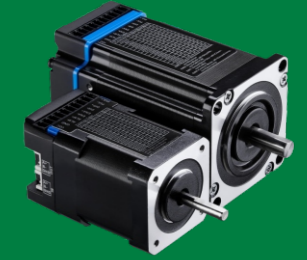

iEM & iCS Series

- Replace iST and iES integrated motor
- Motor Frame: NEMA17,23,24
- Enhanced compact design
- Smoother, No hunting

Introduction

- ▶ iEM series is integrated open-loop stepper motor with Leadshine's latest digital stepper technology.
- ▶ iCS series is integrated closed-loop stepper motor with 14-bit single-turn absolute encoder for smooth and jitter-free motor start-up.
- ▶ iEM and iCS series motors output torque can up to 3.5Nm and supports Modbus RS485 communication with Indexer control function. And with a more compact design, it is especially suitable for applications with strict mounting space requirements, and it is easy to use, which can further reduce customers' procurement and labor costs.



Encoder Specifications (only for iCS series)

Encoder Type	Single-turn absolute magnetic encoder
Encoder Resolution	14-bit
Angle Calibration	Be sure to calibrate after encoder installation

Motor Specifications

Step Angle	1.8°		
Position Accuracy	±0.09°		
Max Temperature	95° C		
Operation Environment	Temperature: -10° C ~ 50° C; Humidity: 85%RH Max		
IP Rate	IP20		
Radial Load (N) (Distance to the flange 10mm)	NEMA17	NEMA23	NEMA24
	30	75	90
Axial Load (N)	Less than motor weight		

■ Integrated Stepper Motor Overview

Models	Type & Frame	Operating Voltage (VDC)	Control Mode	Holding Torque (N.m)	Logical Voltage (VDC)	Motor Length (mm)	
iEM-1703	Open Loop NEMA17	20-36	Pulse&Dir	0.3	5	64	
iEM-1706		20-36		0.6		72	
iEM-1708		20-36		0.8		85	
iEM-RS1706		RS485 Modbus	20-36	0.6		12-24	73
iEM-RS1708			20-36	0.8		12-24	86
iEM-2313	Open Loop NEMA23	20-50	Pulse&Dir, CW&CCW	1.3	5	75	
iEM-2323		20-50		2.3		96	
iEM-2321-L		20-50		2.1		89	
iEM-2331-L		20-50		3.1		109	
iEM-RS2313		RS485 Modbus		20-50		1.3	12-24
iEM-RS2323	20-50		2.3	12-24	99		
iEM-2430	Open Loop NEMA24	20-50	Pulse&Dir, CW&CCW	3.0	5	109	
iEM-2435		20-50		3.5		122	
iCS-1703	Closed Loop NEMA17	20-36	Pulse&Dir	0.3	5	64	
iCS-1706		20-36		0.6		72	
iCS-1708		20-36		0.8		85	
iCS-RS1706		RS485 Modbus	20-36	0.6		12-24	73
iCS-RS1708			20-36	0.8		12-24	86
iCS-2313	Closed Loop NEMA23	20-50	Pulse&Dir, CW&CCW	1.3	5	75	
iCS-2323		20-50		2.3		96	
iCS-2321-L		20-50		2.1		89	
iCS-2331-L		20-50		3.1		109	
iCS-RS2313		RS485 Modbus		20-50		1.3	12-24
iCS-RS2323	20-50		2.3	12-24	99		
iCS-2430	Closed Loop NEMA24	20-50	Pulse&Dir, CW&CCW	3.0	5	109	
iCS-2435		20-50		3.5		122	

■ iEM & iCS Interface

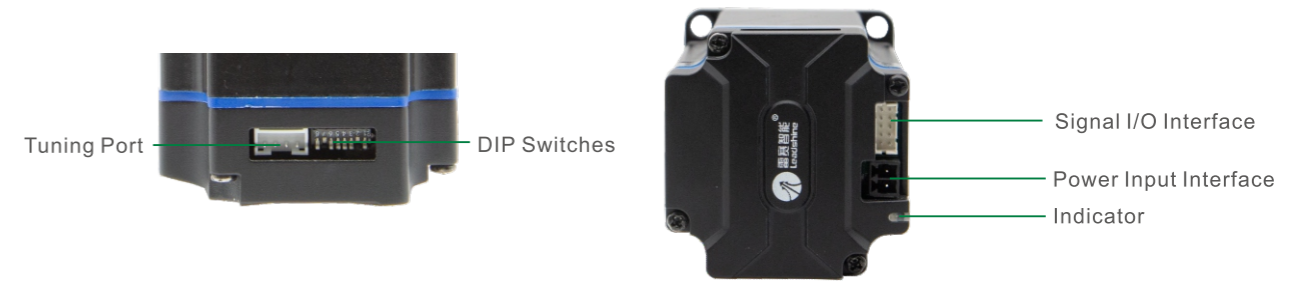

Port	Description
DIP Switches	SW1-SW4: Microstep SW5: Motor Direction SW6: PUL&DIR and CW&CCW selection SW7: Smoothing filtering time SW8: Activated pulse edge for iEM series Open/closed loop control selection for iCS series
I/O Port	PUL+/-, DIR+/-, ENA+/-, ALM+/-

■ Dimensions

(unit: mm, 1 inch=25.4 mm)

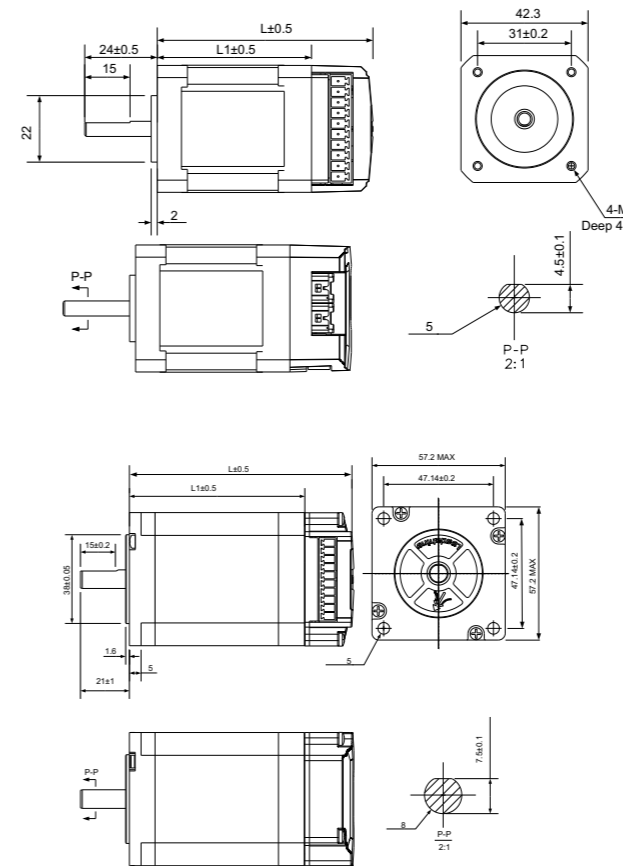

Models	L1 length	L length
iCS-1703	43	64
iCS-1706	51	72
iCS-1708	64	85

Models	L1 length	L length
iCS-2313	43	64
iCS-2323	51	72
iCS-2321-L	64	85
iCS-2331-L	88	109
iCS-2430	88	109
iCS-2435	101	122

■ Tuning Cable & Software

Cable Model	CABLE-PC-1
Software Name	StandardProTuner

■ iEM-RS & iCS-RS Interface

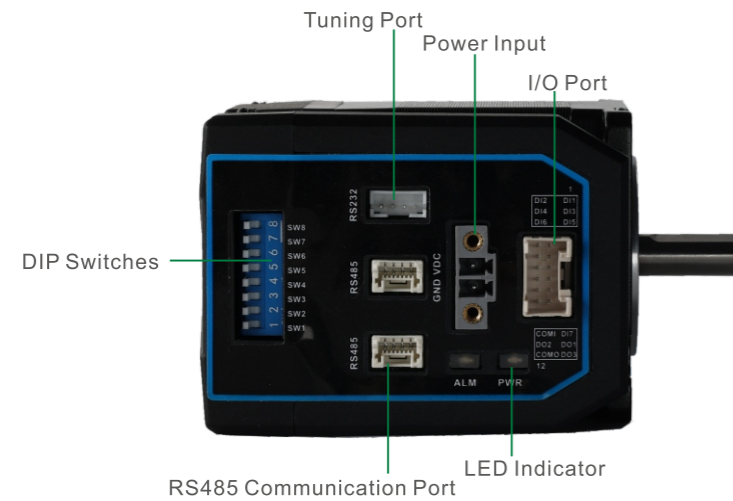

Port	Description
DIP Switches	SW1-SW5: Node ID SW6-SW7: Baud Rate SW8: 120Ω Terminal Resistance
I/O Port	7 digital inputs, 3 digital outputs

■ Dimensions

(unit: mm, 1 inch=25.4 mm)

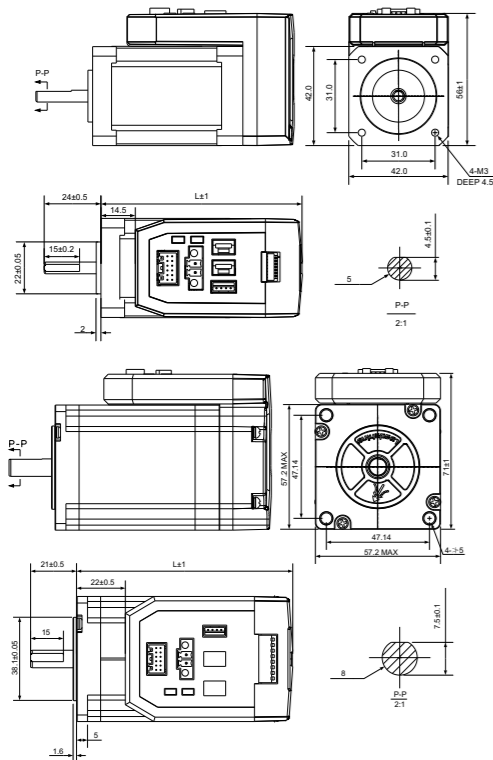

Models	Length(L)
iCS-RS1706	73 mm
iCS-RS1708	86 mm

Models	Length(L)
iCS-RS2313	78 mm
iCS-RS2323	99 mm

■ Tuning Cable & Software

Cable Model	CABLE-PC-1
Software Name	StandardProTuner

Power Supplies

- 260W: 24VDC output
- 360W: 24VDC/36VDC/48VDC output
- 400W: 60VDC output



LSP Series----Power Supplies

■ Features

- ▶ 1.8 times overload
- ▶ Compact Size, Light in Weight
- ▶ Use Switch to select input voltage 220VAC ± 10% or 110 VAC ± 10%
- ▶ Over-current, Over-voltage, Low-voltage Protections
- ▶ Big Power with High Efficiency
- ▶ CE and RoHS

■ Electrical Specifications

Model	Output Voltage (VDC)	Continuous Current(A)	Peak Current(A)	Input Voltage	Power (W)	Dimensions (mm)	Weight (kg)
LSP-260-24	24	10.8	19.4	220VAC ± 10% or 110 VAC ± 10%	260	199*110*50	0.8
LSP-360-24	24	15	27		360	199*110*50	0.8
LSP-360-36	36	10	18		360	215*115*30	0.7
LSP-360-48	48	7.5	13.5		360	215*115*30	0.7
LSP-400-60	60	6.7	12		400	215*115*30	0.7

■ Dimensions

(unit: mm, 1inch=25.4mm)

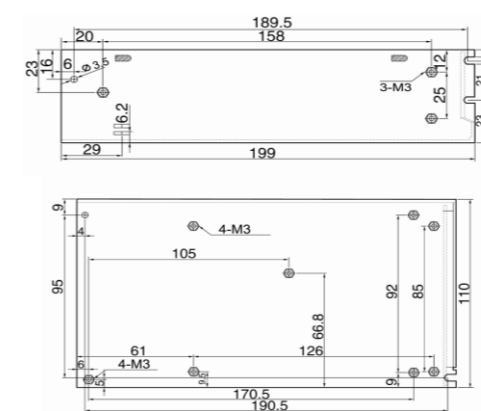

LSP-260-24, LSP-360-24

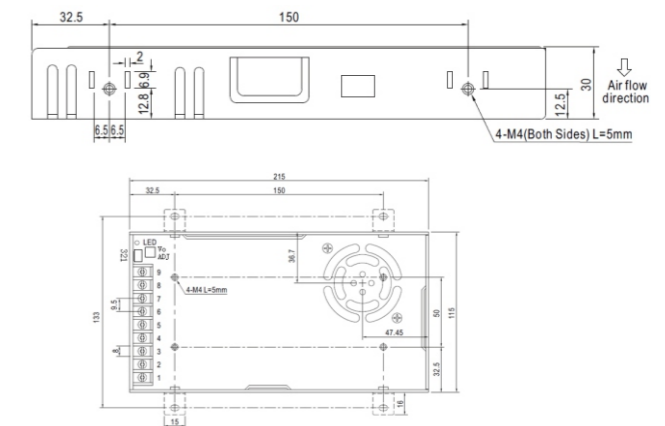

LSP-360-36, LSP-360-48, LSP-400-60

Gearboxes

- Straight tooth planetary Gearbox
- Matched 23, 24, 34 stepper motors
- Gear ratio 3:1, 5:1, 7:1, 10:1 are available

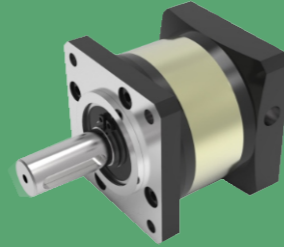

Specifications

Size	60mm				90mm			
Gear Ratio	3	5	7	10	3	5	7	10
Rated Output Torque (Nm)	16.5	29.5	19.5	8.5	60	94	64	40
Max Output Torque(Nm)	33.0	59.0	39.0	17.0	120	188	128	80
Rotation Inertial(10⁻⁴kgm²)	0.107	0.092	0.091	0.091	0.4	0.291	0.285	0.283
Rated Input Rotation Speed (RPM)	4000				3500			
Maximum Input Rotation Speed (RPM)	8000				6000			
Maximum Radial Force (N)	485				1020			
Maximum Axial Force (N)	380				850			
Free-load torque (N.m)	0.6				0.8			
Full-load Efficiency	96%				96%			
Backlash (arcmin)	<12				<12			
Noise (dB)	≤58				≤62			
Weight (kg)	1.0				2.8			
Torsional Rigidity	2.3				7.5			
Average Life (h)	>20000							
Lubricant	Long-term Lubrication							
Rotation Direction	Input and output in the same direction							
Protection Class	IP65							
Installation Way	Arbitrariness							

Model	Gear Ratio	Matched Motors
PLF060-3-P2-BJ-6.35-38.1	3:1	NEMA 23 Stepper Motor with 6.35mm Shaft Diameter
PLF060-5-P2-BJ-6.35-38.1	5:1	
PLF060-7-P2-BJ-6.35-38.1	7:1	
PLF060-10-P2-BJ-6.35-38.1	10:1	
PLF060-3-P2-BJ-8-38.1	3:1	NEMA 23 Stepper Motor with 8mm Shaft Diameter
PLF060-5-P2-BJ-8-38.1	5:1	
PLF060-7-P2-BJ-8-38.1	7:1	
PLF060-10-P2-BJ-8-38.1	10:1	
PLF090-3-P2-BJ-12.7-73	3:1	NEMA 34 Stepper Motor with 12.7mm Shaft Diameter
PLF090-5-P2-BJ-12.7-73	5:1	
PLF090-7-P2-BJ-12.7-73	7:1	
PLF090-10-P2-BJ-12.7-73	10:1	
PLF090-3-P2-BJ-14-73	3:1	NEMA 34 Stepper Motor with 14mm Shaft Diameter
PLF090-5-P2-BJ-14-73	5:1	
PLF090-7-P2-BJ-14-73	7:1	
PLF090-10-P2-BJ-14-73	10:1	
PLF090-3-P2-BJ-14-60	3:1	NEMA 34 Closed Loop Stepper Motor with 14mm Shaft Diameter
PLF090-5-P2-BJ-14-60	5:1	
PLF090-7-P2-BJ-14-60	7:1	
PLF090-10-P2-BJ-14-60	10:1	